

Arquitecturas convergentes: predicción, eficiencia, negocio

Jorge JIMENEZ
DCIM & Data Center Life Cycle Services Product Manager















El volumen de datos
generados a escala mundial
se **duplica**

cada 2 años

En 2010

el **50**% de la población mundial tenía **menos de 30** año

En **2010**

el **96%** se había unido a una red social







Vehicle, asset, person & pet monitoring & controlling



Agriculture automation



Energy consumption



Security & surveillance

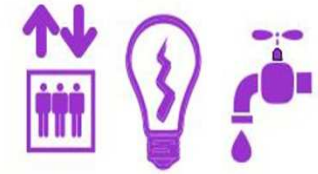

Building management

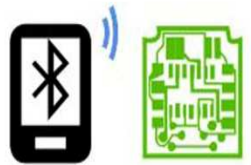

Embedded Mobile

Internet of things

Everyday things get connected  for smarter tomorrow

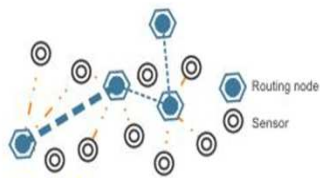

M2M & wireless sensor network



Everyday things



Smart homes & cities

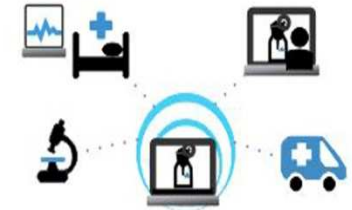

Telemedicine & healthcare

La previsión: en 2030 el 40% consumo energético global asociado a las TI.

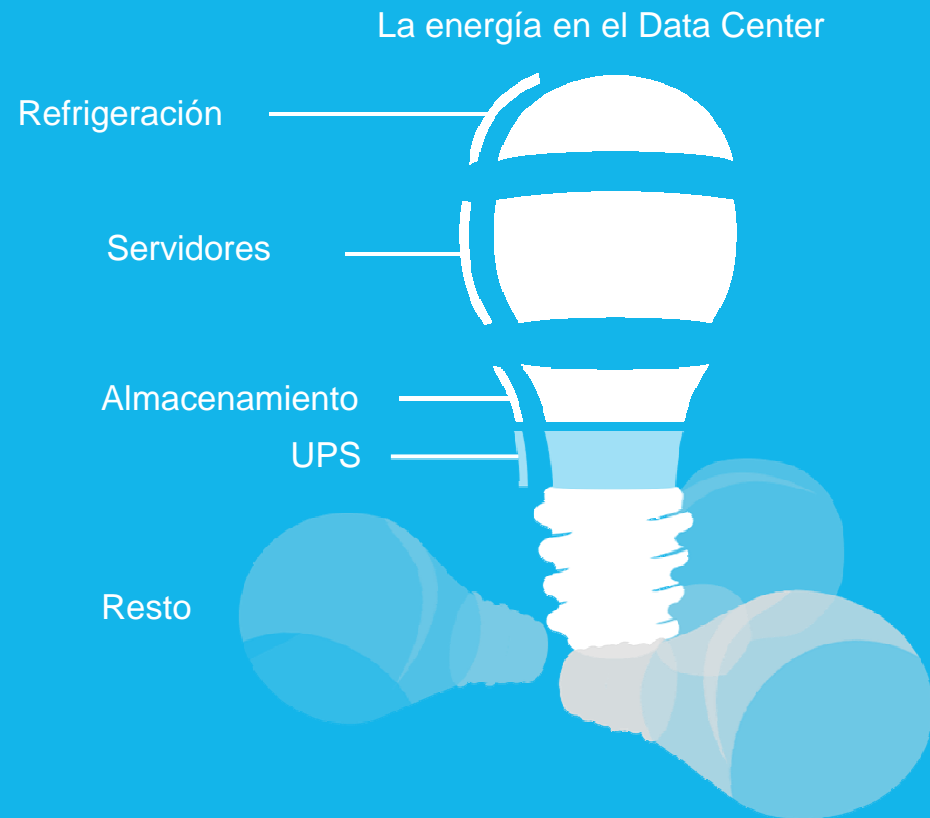

La convergencia de la
energía y el mundo IT abre
un mundo de oportunidades

.....optimizando la energía, los procesos
y la seguridad



Schneider
Electric

La **eficiencia energética** es una práctica que tiene como objeto reducir el consumo de energía. Los individuos y las organizaciones que son consumidores directos de la energía pueden reducir el consumo energético para **disminuir costes** y promover **sostenibilidad económica, política y ambiental**. Los usuarios industriales y comerciales pueden desear **aumentar eficacia y maximizar** así su **beneficio**.

Dispositivos SMART



Medición correcta y fiable y cerca del proceso

Cuadro de Mando

Gestion sostenible



> Mantenimiento

> Eventos

> Alarmas

> Consumos

Iluminación

Contador



Refrigeración

Contador



Estado Interruptor Automático

Disponibilidad



Corriente Max.
Disponibilidad



Disparo
Disponibilidad



Fases Desequilibradas
Medida



Monitorización Harmónicos
Calidad



Sobre Corriente
Calidad



Las arquitecturas eficientes requieren de dispositivos que se adapten al proceso de forma dinámica

Arquitectura: modular

Modularidad INTERNA



Unidades con capacidad interna escalable

Modularidad POD

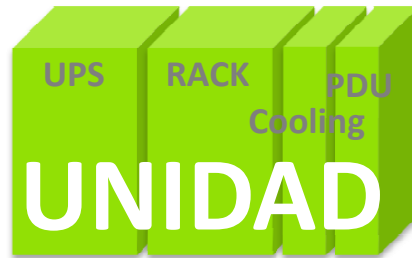

Unidades "complementarias" forman el POD



"Step-and-repeat" para Centros de Datos grandes

Modularidad SUBSISTEMA

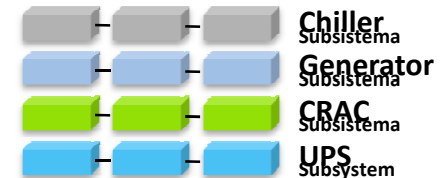

Varias unidades de grandes subsistemas

Pequeño

Grande

A background image showing a dense pile of various colored LEGO bricks (yellow, grey, blue, red, white, green) scattered across the frame. The bricks are of different shapes and sizes, including standard 1x2 and 1x3 bricks, as well as some specialized pieces like Technic connectors and pins. The overall appearance is that of a large, unsorted collection of building blocks.

Arquitectura: modular

- **Disponibilidad**
- **Escalabilidad**
- **Flexibilidad**
- **Eficiencia**

CAPEX y OPEX

Arquitectura: convergente



Arquitectura: convergente

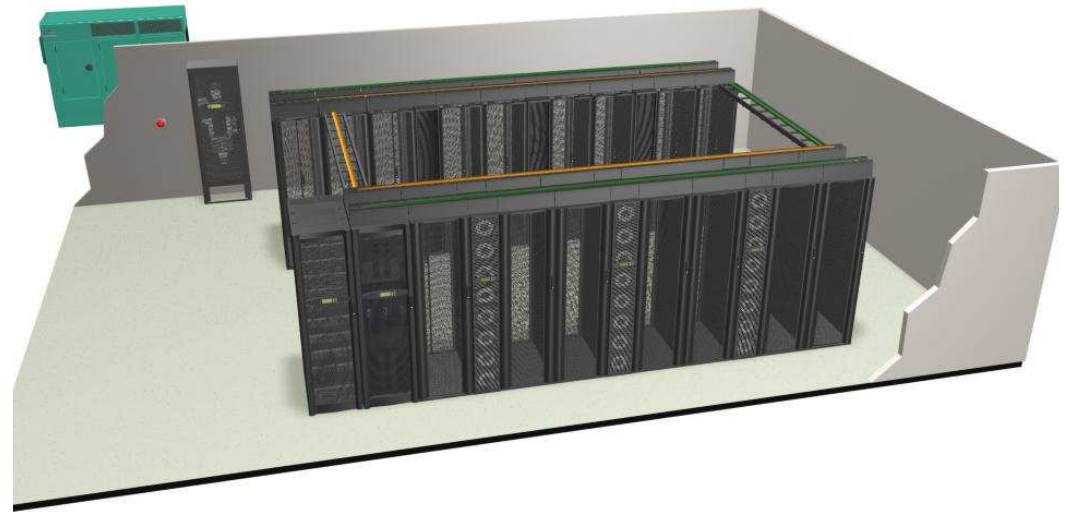
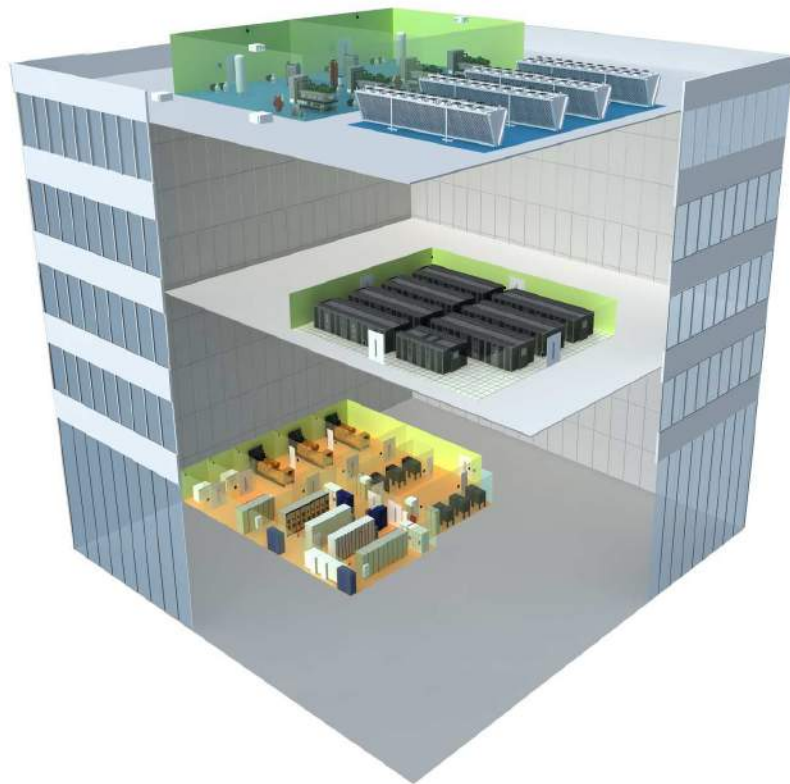

Arquitectura: convergente

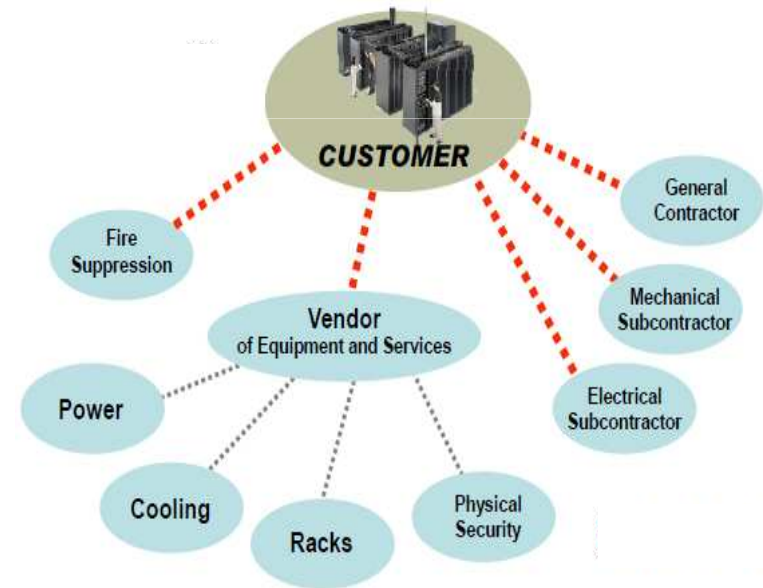
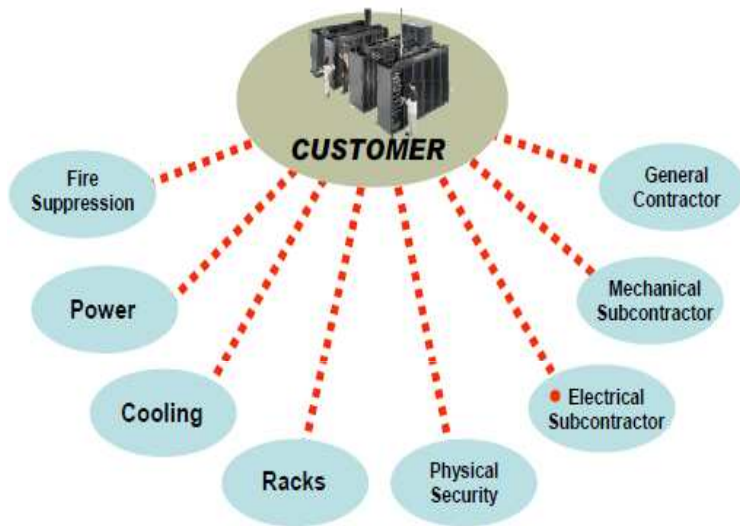

Compartimos el conocimiento

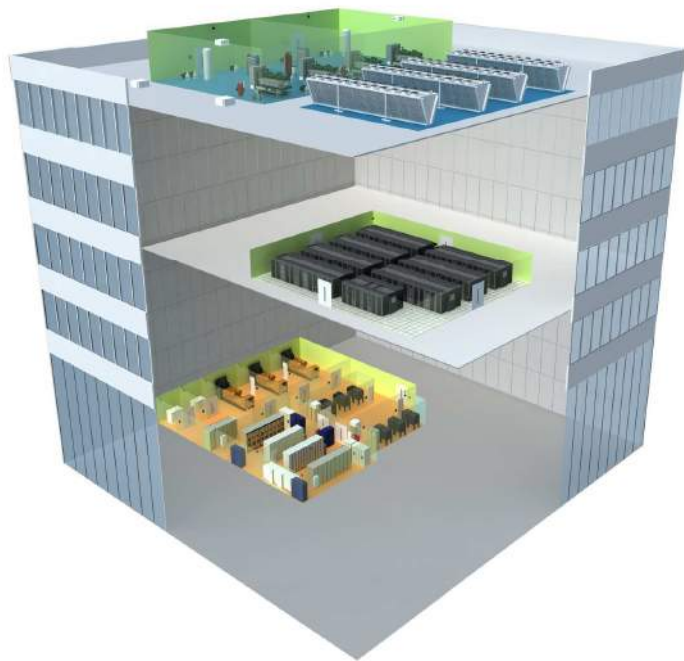

> White Paper App (+150)



> Data Center Reference Designs

IT Capacity, Tier, PUE, €/Watt

Best Practices



> TradeOff Tools



> Schneider Electric Design Portal

DCIM



DCIM

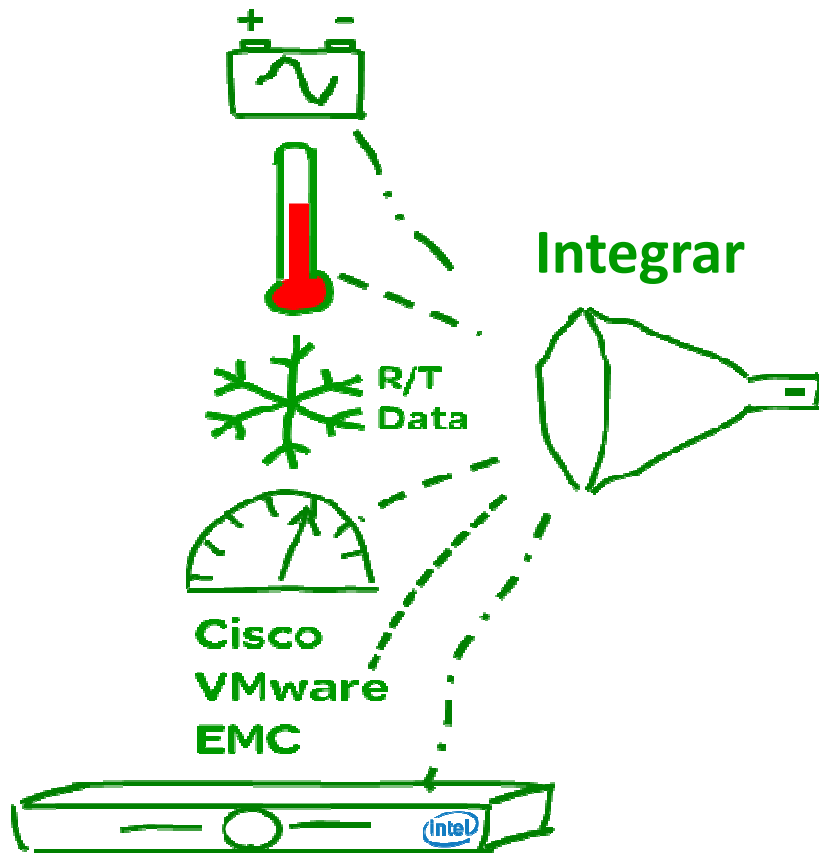

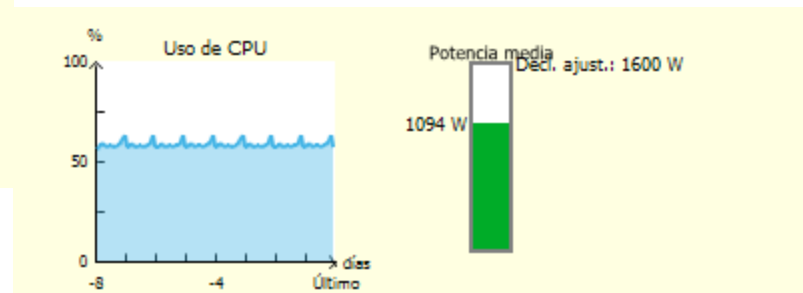
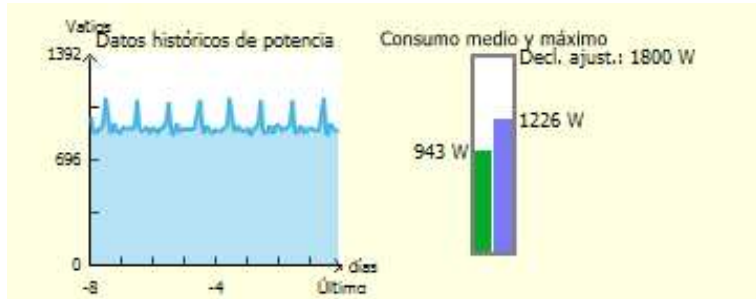
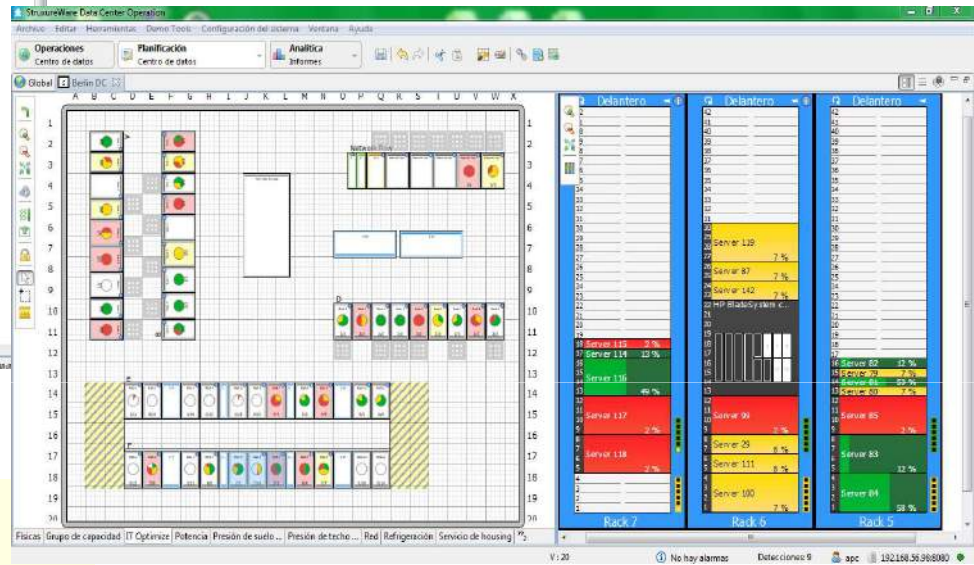
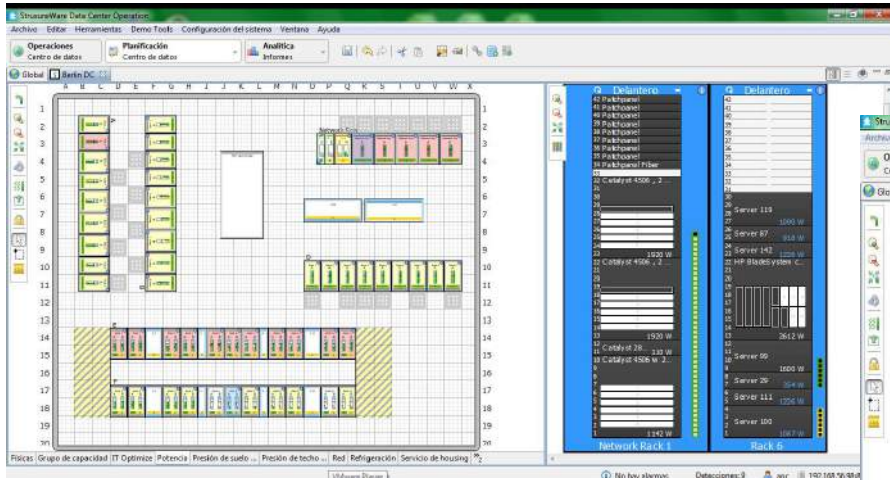

COMPASS Datacenters

ACTIVE ALARMS: 1 CRITICAL 0 NON-CRITICAL

70.2°F 41%rh 11:27 AM

68°F Fair
 Sun: 81/79° Sunny
 Mon: 80/75° Sunny
 Tue: 80/75° Sunny
 Last Update: Wed, 24 Oct 2012 10:51 am EDT

Building Energy Data & Sub Meter

ENERGY DATA

Building Loads & Main Meter

BUILDING LOAD

Home
 Floorplans
 Equipment
 Energy
 Schedules
 Trends

Source: admin Domain: Local

Plant Optimization Summary

61.0°F 41%rh 12:47 PM

ENERGY DATA

BUILDING LOAD

CONTROL PANEL

Summary
 Setpoints
 Alarms

Source: admin Domain: Local

Schneider Electric StruxureWare Power Monitoring

Dashboard Diagrams Tables Alarms Reports

Equipment Detail - Network A - Main Switchboard

Power Readings:

Power:	
KW A	245.3 kW
KW B	245.3 kW
KW C	245.3 kW
KW Total	735.9 kW
Frequency	60.0 Hz
Current:	
I A	1,013.6 A
I B	1,013.6 A
I C	1,013.6 A
Voltage:	
VI AB	408.5 V
VI BC	408.5 V
VI CA	408.5 V

Single Line Diagram

Main Switchboard A Vn: 410V In bus: 4000A Ibc: 80 kA/Ls

714.6 kW
1,418.3 A
-05.5 V

14.7 A

0.0 A

70.2 A

714.6 kW
1,418.3 A
-05.5 V

0.0 kW
0.0 A

70.2 A

Aux Supplies Board A

Status Panel

Medium Voltage	Low Voltage	IT Floor
Utility Switchgear A	Main Switchboard A	PDU A.1
Utility Switchgear B	Main Switchboard B	PDU A.2
Main Transformer A	Generator Switchboard	PDU A.3
Main Transformer B	Mechanical Distribution A	PDU A.4
	Mechanical Distribution B	PDU A.5
	IT UPS Input Board A	PDU A.7
	IT UPS Input Board B	PDU A.8
Generator A	IT UPS Output Board A	PDU B.1
Generator B	IT UPS Output Board B	PDU B.2
IT UPS A	Auxiliaries Supplies Board A	PDU B.3
IT UPS B	Auxiliaries Supplies Board B	PDU B.4
Mechanical UPS A	Mechanical UPS Board A	PDU B.5
Mechanical UPS B	Mechanical UPS Board B	PDU B.6
		PDU B.7
		PDU B.8

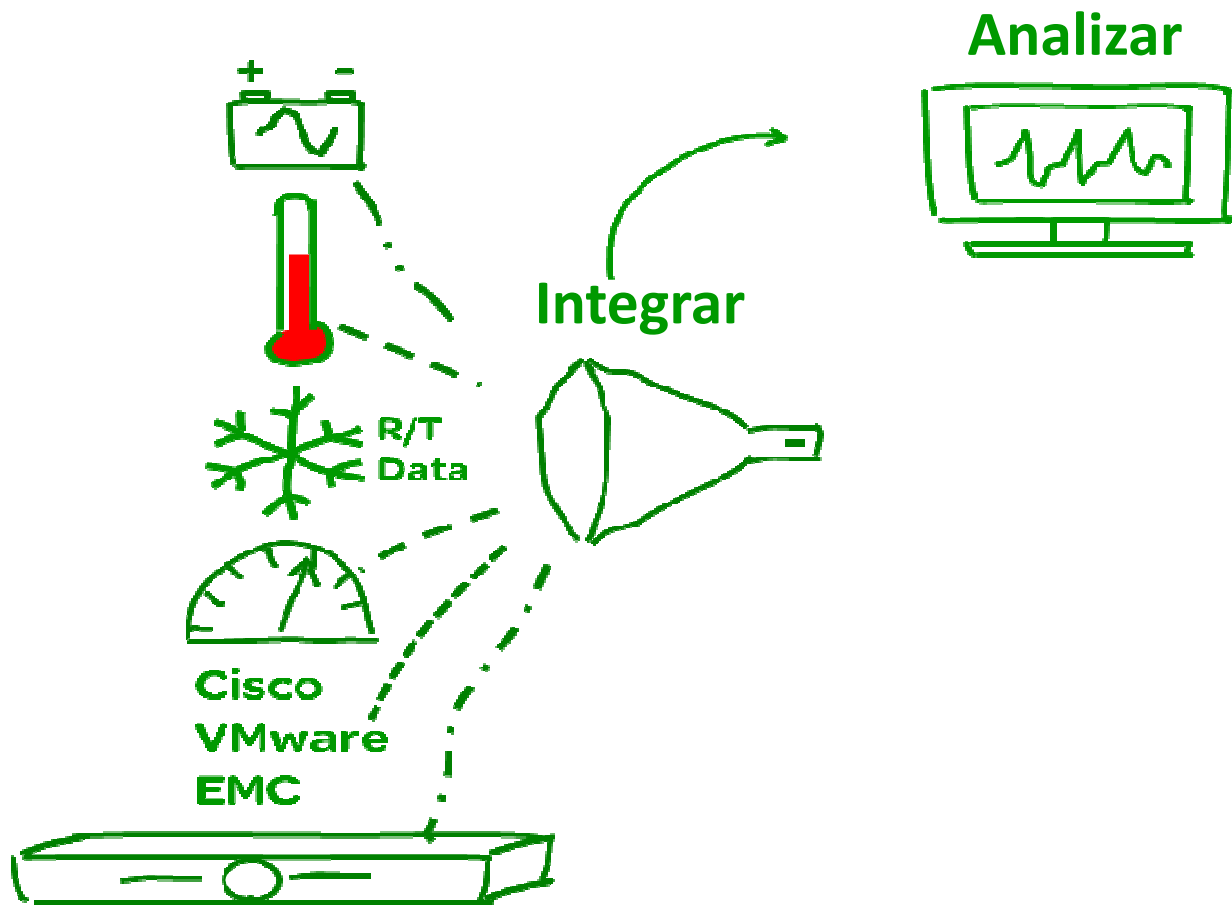

Analizar de manera global

Información Energética - sin contexto



Consumo 10L/100 km



Consumo 10L/100 km

Información Energética – con Contexto



Consumo 10L/100 km



Consumo 10L/100 Km

Perfil

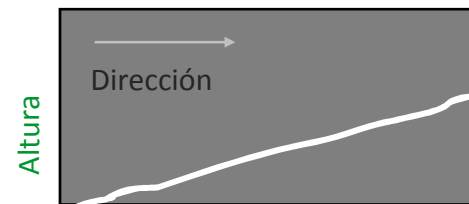

Distancia

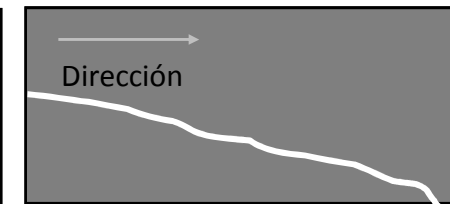

Distancia

Analizar de manera global

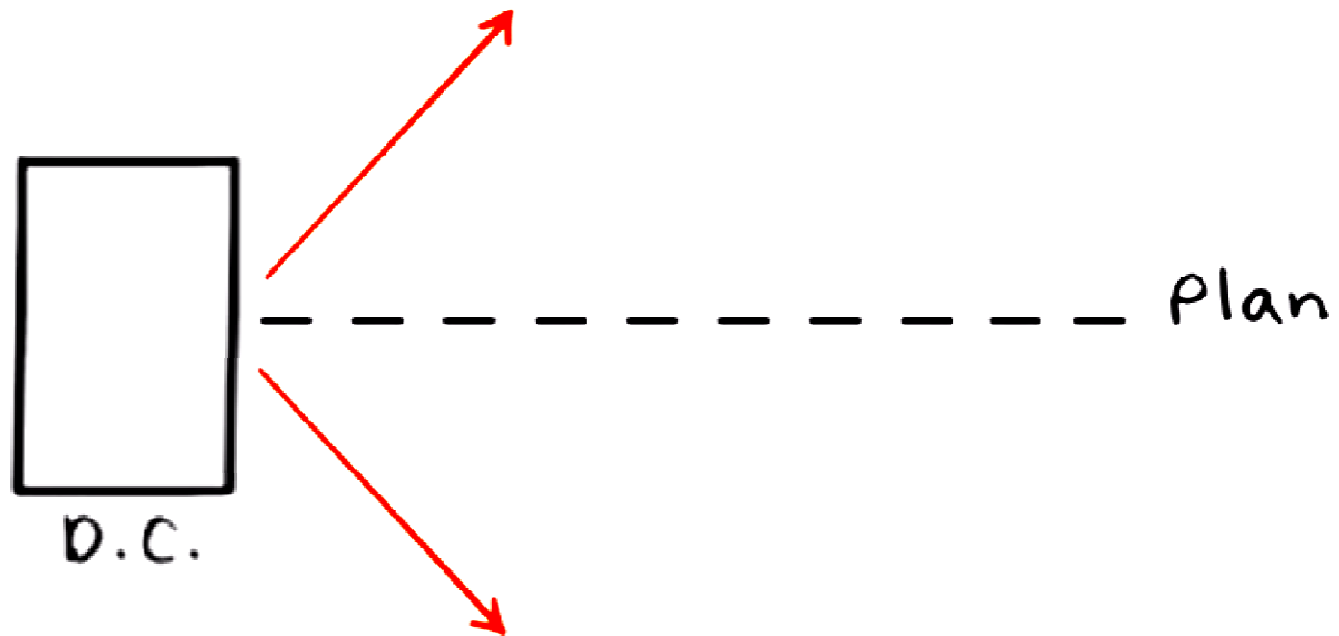

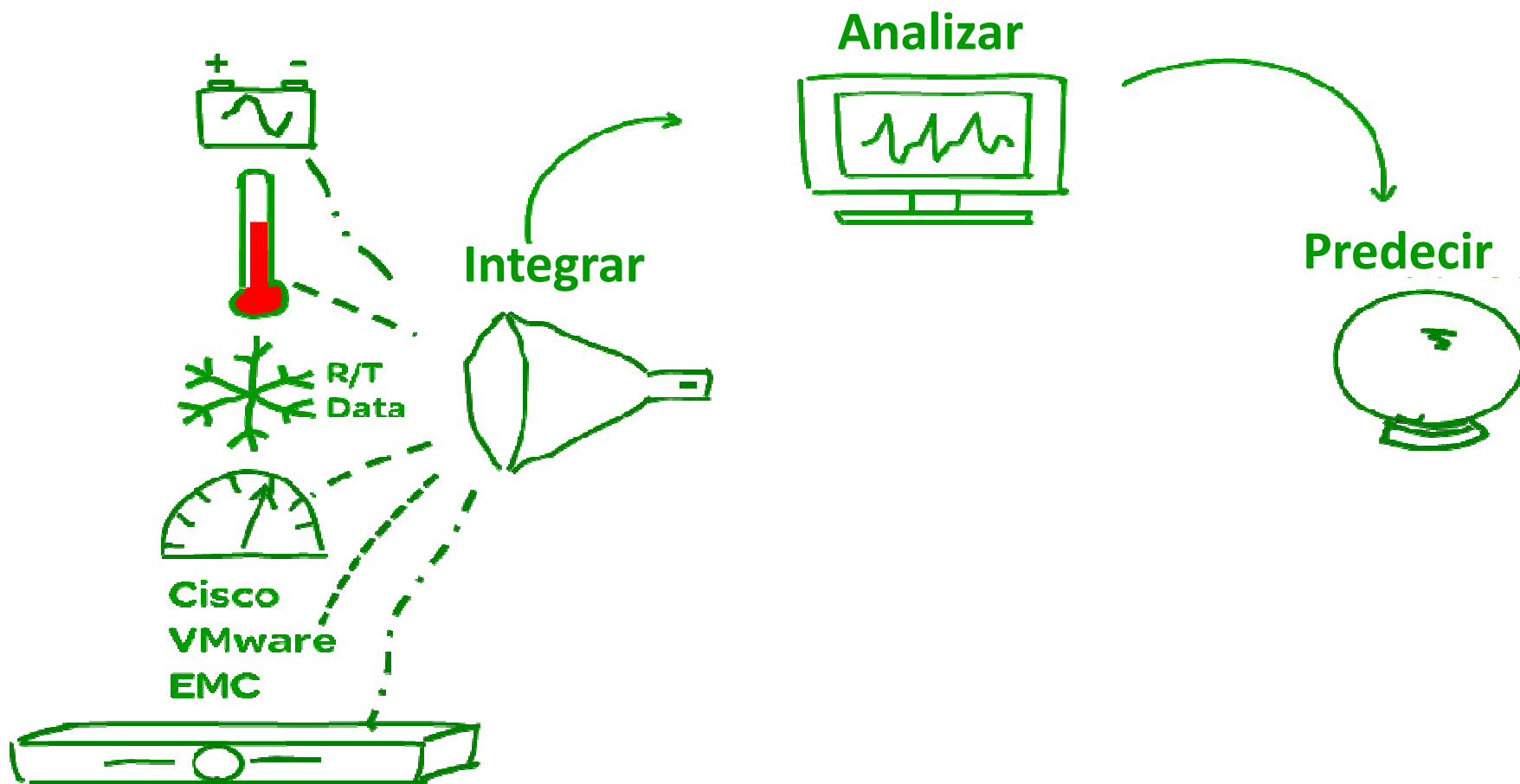

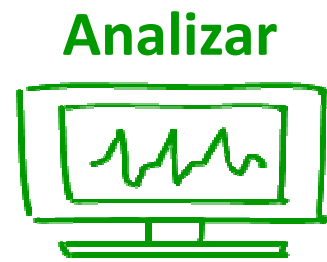
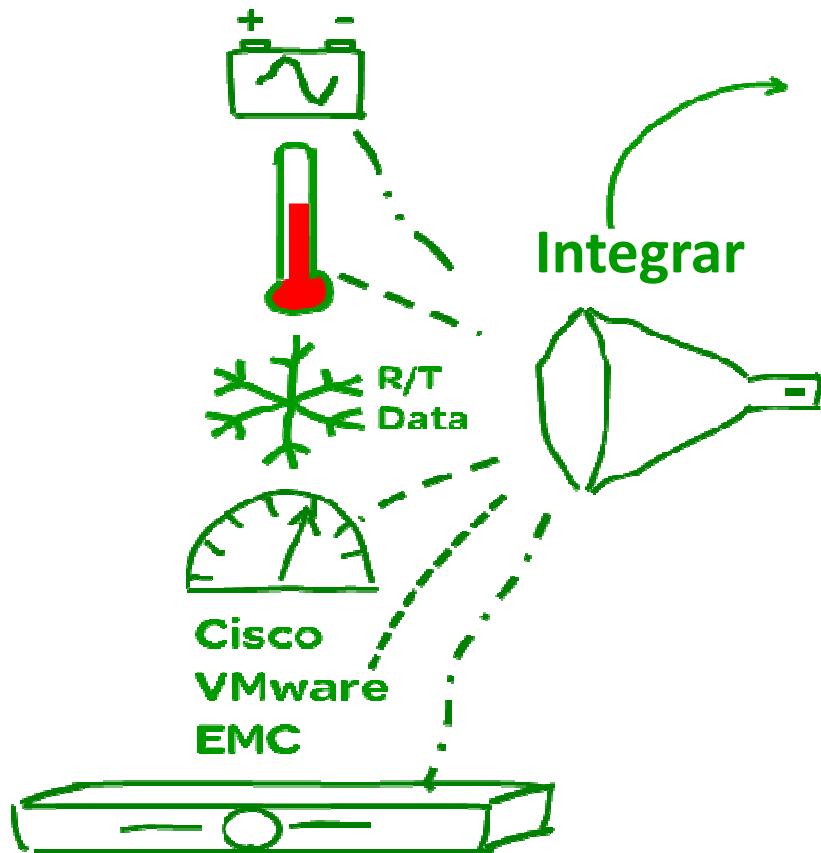

Predecir



Optimizar

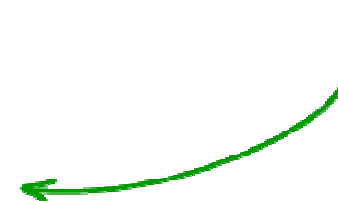
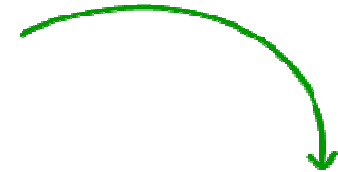
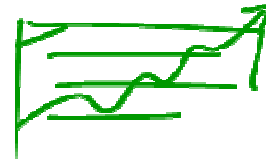

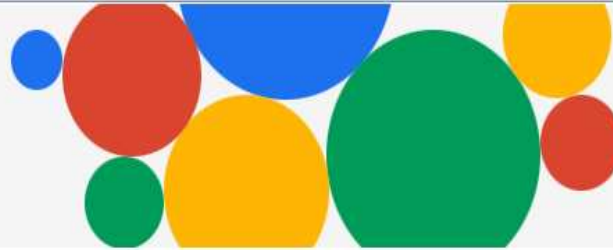

Better data centers through machine learning

Posted: Wednesday, May 28, 2014

1,233

Tweet 672

Me gusta

It's no secret that we're obsessed with saving energy. For over a decade we've been designing and building data centers that use half the energy of a typical data center, and we're always looking for ways to reduce our energy use even further. In our pursuit of extreme efficiency, we've hit upon a new tool: machine learning. Today we're releasing a white paper (PDF) on how we're using neural networks to optimize data center operations and drive our energy use to new lows.

It all started as a 20 percent project, a Google tradition of carving out time for work that falls outside of one's official job description. Jim Gao, an engineer on our data center team, is well-acquainted with the operational data we gather daily in the course of running our data centers. We calculate PUE, a measure of energy efficiency, every 30 seconds, and we're constantly tracking things like total IT load (the amount of energy our servers and

Search



Google

google.com/+google

News and updates on Google's products, technology and more

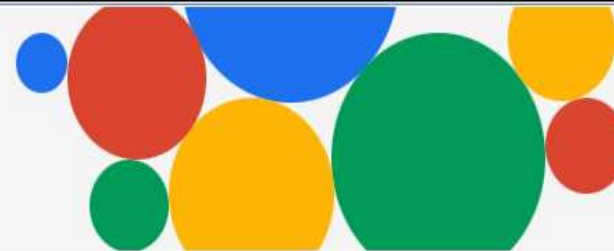

Better data centers through machine learning

Posted: Wednesday, May 28, 2014

g+1 1,233

Tweet 672

Me gusta

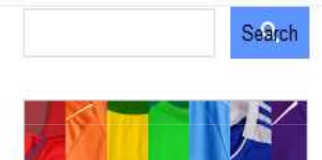

It's no secret that we're obsessed with data centers that use half the energy and use even further. In our pursuit of releasing a white paper (PDF) on energy use to new lows.

It all started as a 20 percent project in an official job description. Jim Gao, who we gather daily in the course of our work, every 30 seconds, and we're con

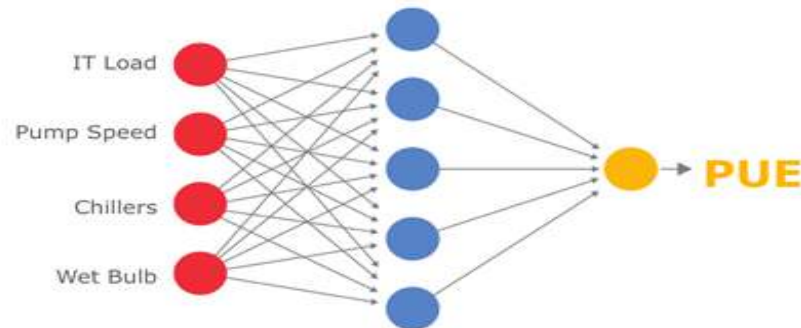

A simplified version of what the models do: take a bunch of data, find the hidden interactions, then provide recommendations that optimize for energy efficiency.

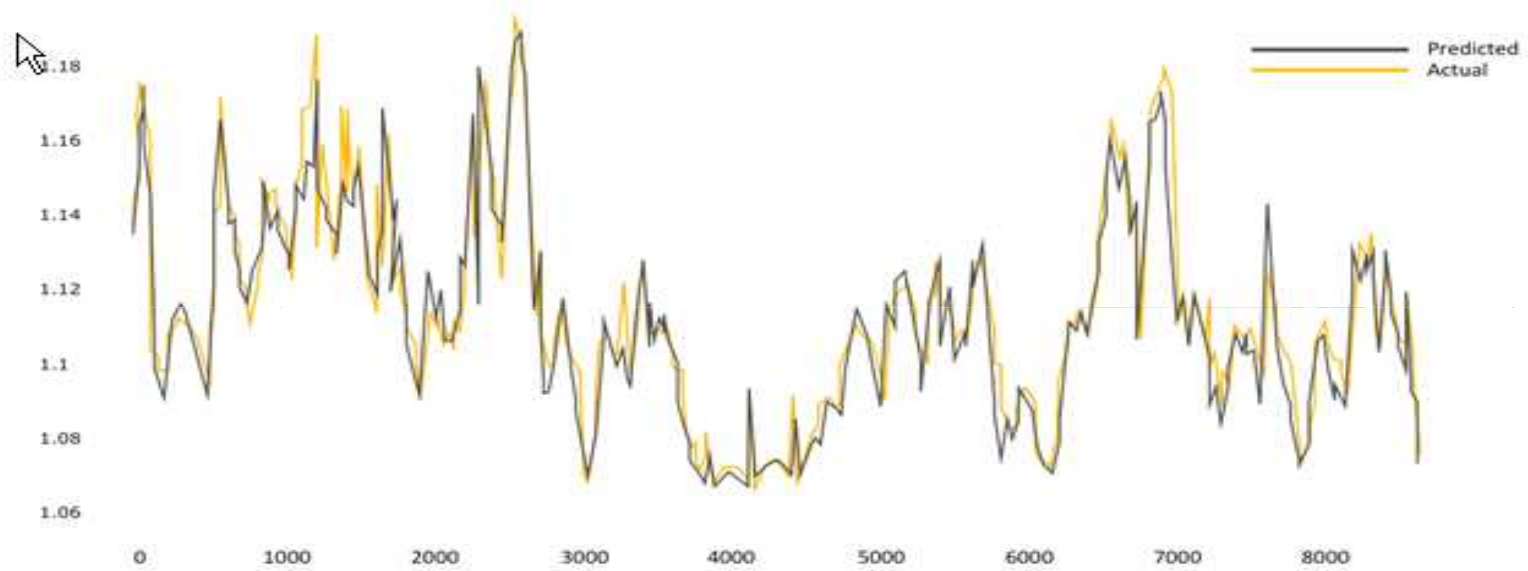

The models can predict PUE with 99.6 percent accuracy.

A simplified version of what the models do: take a bunch of data, find the hidden interactions, then provide recommendations that optimize for energy efficiency.

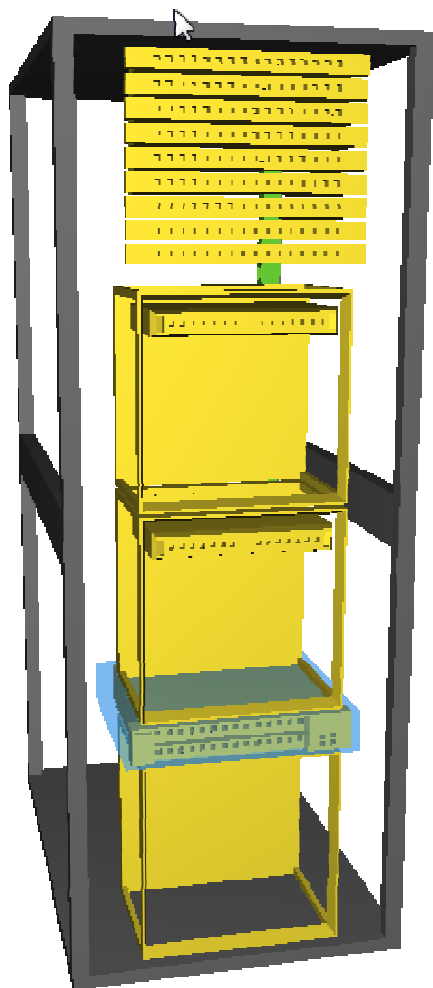

Información sobre el equipo

Nombre: Catalyst 2820
Ubicación: U-11/Network Rack 1/Network

Impacto simulado para Catalyst 2820/U-11/Network Rack 1/Network Row/Berlin DC/Berlin/Emea/

Impacto simulado para Catalyst 2820/U-11/Network Rack 1/Network Row/Berlin DC/Berlin/Emea/

La lista muestra el impacto simulado si el equipo ha fallado.

Nombre	Fabricante	Nombre del modelo	Impacto	Descripción del impacto	Máquinas virtuales y plantillas
Server 71	Dell	PowerEdge 2650	Red	La red no funciona (Server 44, Server 138, Server 13 y 8 más)	Webserver for www.schneider-electric.com, VM for Windows 7, Nightly Test Serv
Server 43	Dell	PowerEdge 2650	Red	La red no funciona (Server 44, Server 138, Server 13 y 8 más)	VM for Ubuntu, VM for Windows 7, Webserver for www.schneider-electric.com, S
Server 137	Dell	PowerEdge 2650	Red	La red no funciona (Server 44, Server 138, Server 13 y 8 más)	VM for Ubuntu, VM for Windows 7, Nightly Test Server, Webserver for www.schn
Server 13	Dell	PowerEdge 2650	Red	La red no funciona (Server 44, Server 138, Server 95 y 8 más)	VM for Ubuntu, SQL server 2014, VM for Windows 7, Webserver for www.schneid
Server 14	Dell	PowerEdge 2650	Red	La red no funciona (Server 44, Server 138, Server 13 y 8 más)	VM for Ubuntu, Nightly Test Server, SQL server 2014, VM for Windows 7, Webserv
Server 78	Dell	PowerEdge 2650	Red	La red no funciona (Server 44, Server 138, Server 13 y 8 más)	SQL server 2014, Webserver for www.schneider-electric.com, VM for Ubuntu, VM
Server 138	Dell	PowerEdge 2650	Red	La red no funciona (Server 44, Server 13, Server 95 y 8 más)	SQL server 2014, VM for Windows 7, Webserver for www.schneider-electric.com, I
Server 77	Dell	PowerEdge 2650	Red	La red no funciona (Server 44, Server 138, Server 13 y 8 más)	SQL server 2014, VM for Ubuntu, VM for Windows 7, Nightly Test Server, Webserv
Server 44	Dell	PowerEdge 2650	Red	La red no funciona (Server 138, Server 13, Server 95 y 8 más)	SQL server 2014, VM for Ubuntu, VM for Windows 7, Nightly Test Server, Webserv
Server 72	Dell	PowerEdge 2650	Red	La red no funciona (Server 44, Server 138, Server 13 y 8 más)	SQL server 2014, Nightly Test Server, VM for Windows 7, Webserver for www.schn
Server 95	Dell	PowerEdge 2650	Red	La red no funciona (Server 44, Server 138, Server 13 y 8 más)	

11 elementos mostrados

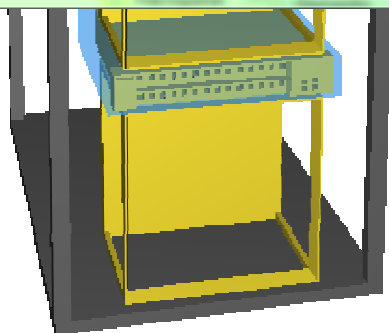

Información sobre el equipo



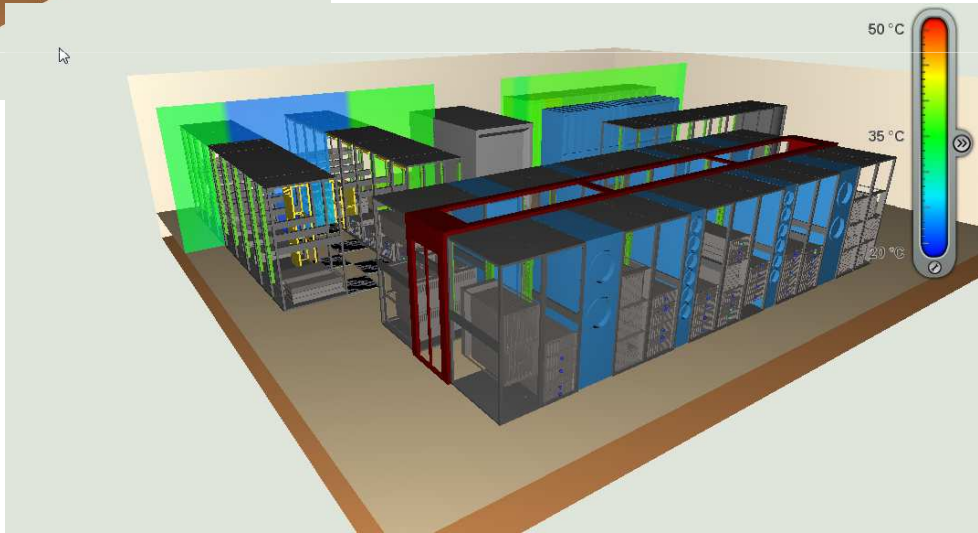
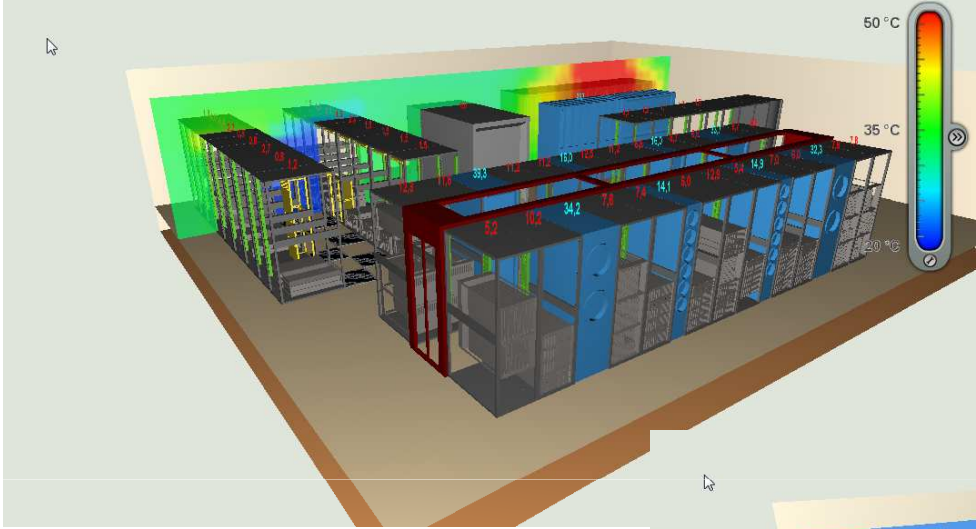

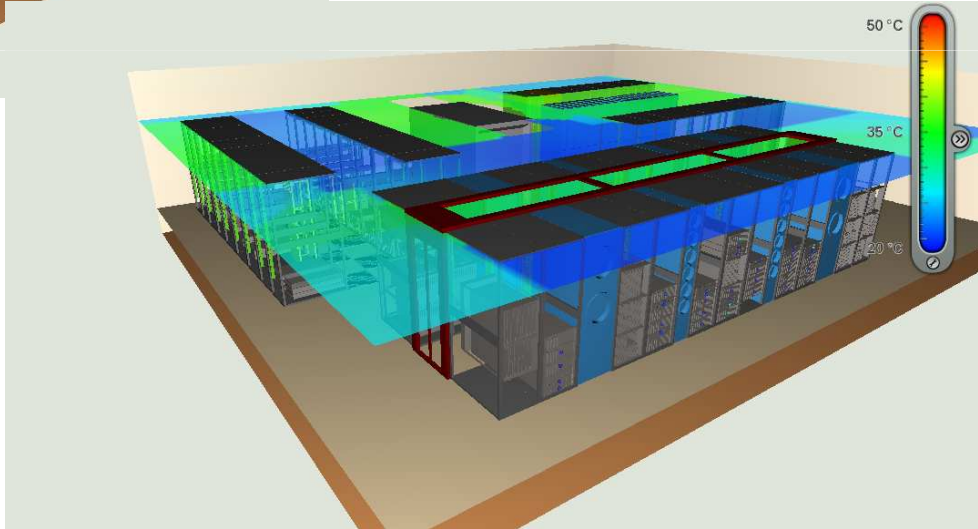
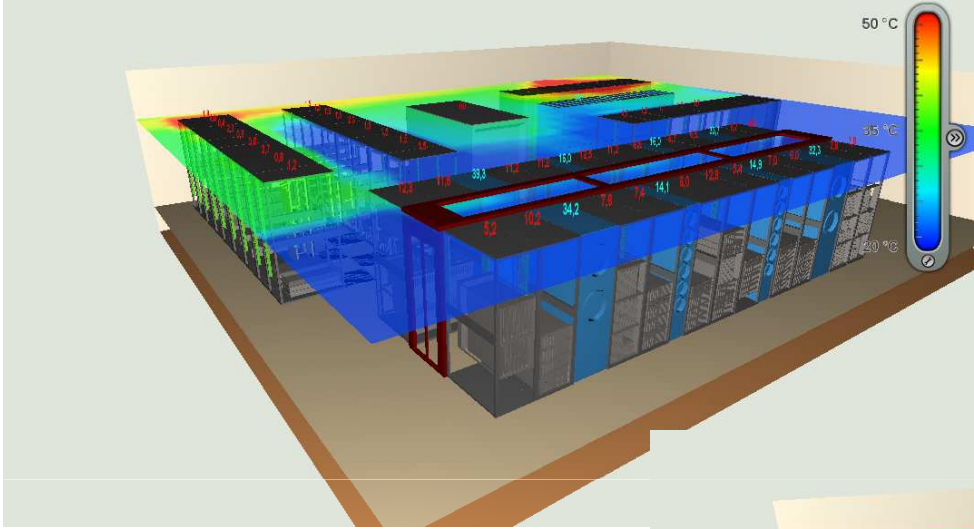

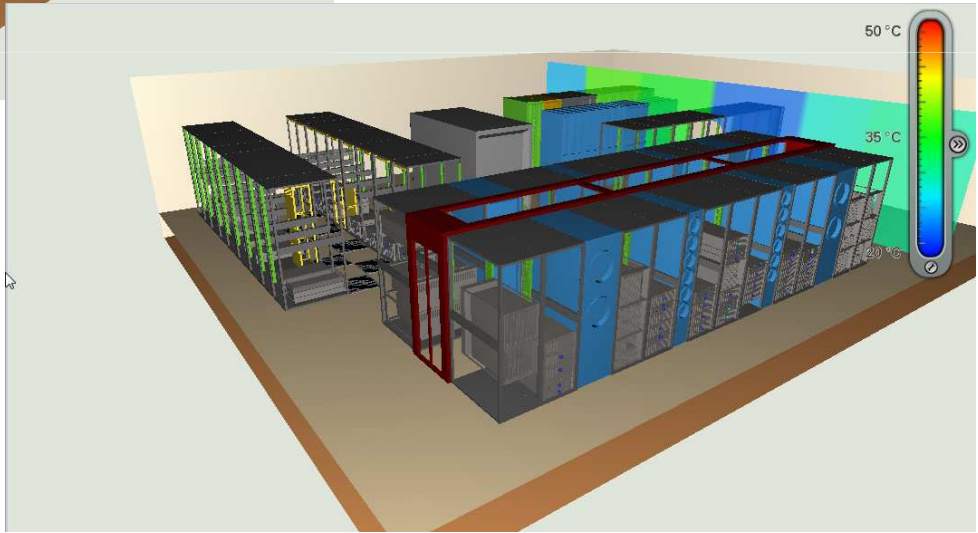
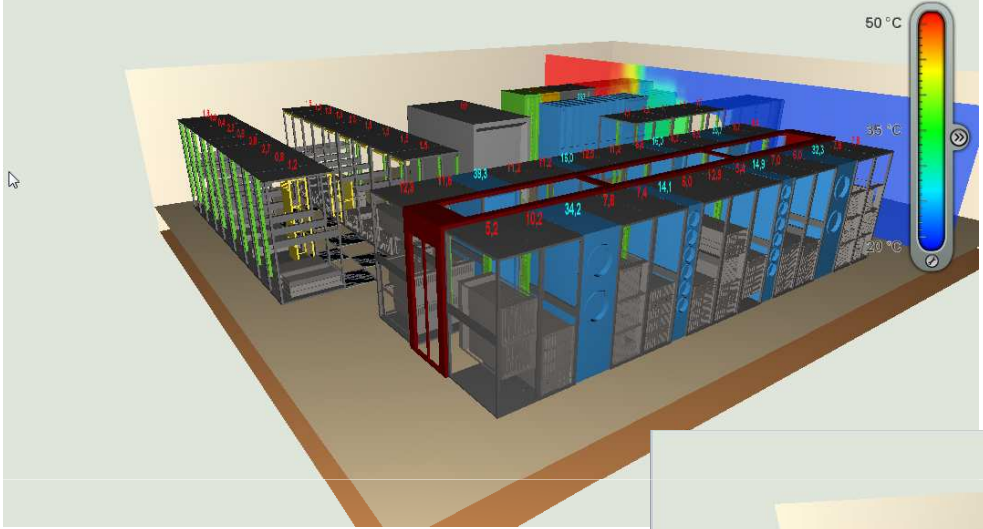

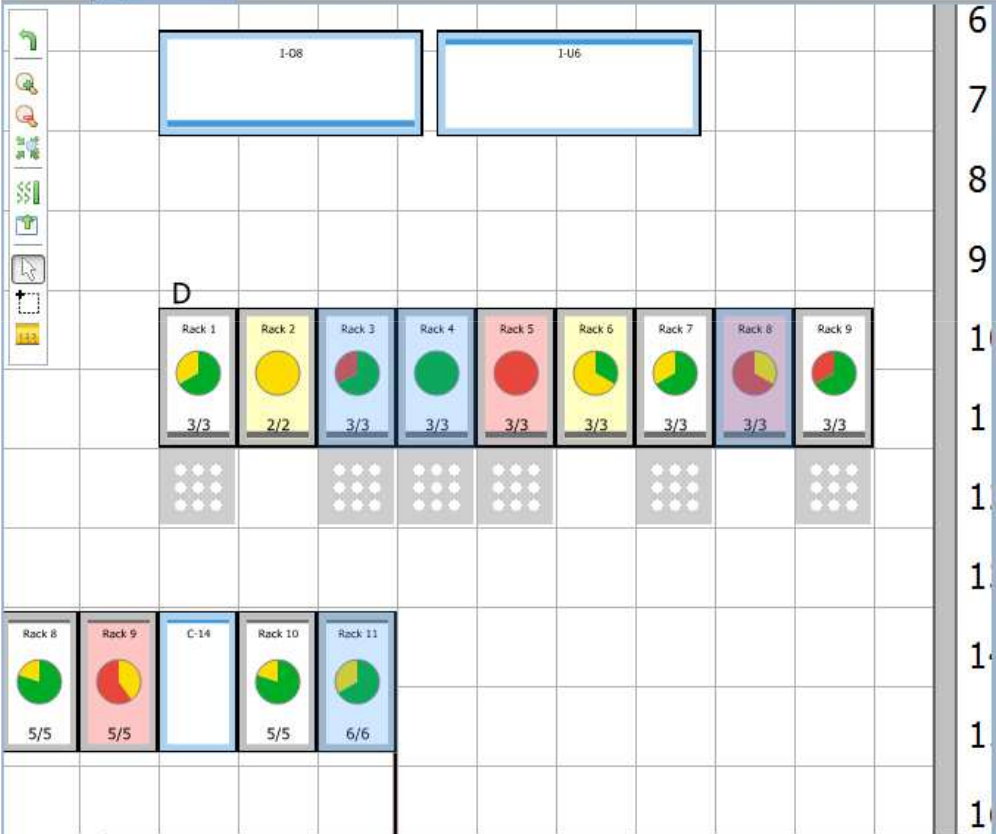





Nombre: Catalyst 2820
 Ubicación: U-11/Network Rack 1/Network









Nombre del dispositivo	Uso medio de CPU (%)	Tipo
 Buscar...	Buscar...	invitado virtual
 Virtual guest 112	0,0	Invitado virtual
 Virtual guest 153	1,4	Invitado virtual
 Virtual guest 154	1,4	Invitado virtual
 Virtual guest 111	0,0	Invitado virtual
 Virtual guest 115	3,5	Invitado virtual
 Virtual guest 150	0,0	Invitado virtual
 Virtual guest 110	0,0	Invitado virtual
 Virtual guest 109	3,0	Invitado virtual
 Virtual guest 149	0,7	Invitado virtual
 Virtual guest 114	3,7	Invitado virtual
 Virtual guest 148	27,6	Invitado virtual
 Virtual guest 155	1,4	Invitado virtual
 Virtual guest 117	0,9	Invitado virtual

U-3

General

Tipo: Ups
Ubicación: Network Row/Berlin DC/Berlin/Emea/
Código de barras: -

Potencia

Capacidad: 500,00 kW
PDU conectada: P-2
Ubicación de la PDU: Network Row/Berlin DC/Berlin/Emea/
Alimentación: Alimentación B
Redundancia interna: N+1

Capacidad

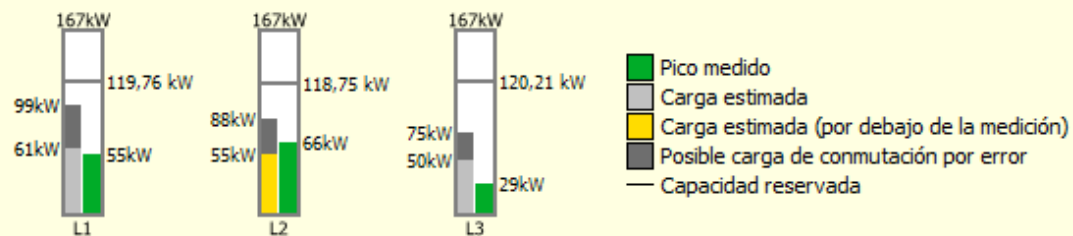

Capacidad reservada: 358,72 kW (71,7 %)

Carga estimada: 165,91 kW (262,23 kW en el caso de la conmutación por error de un SAI)

Recomendación

⚡ La carga medida del SAI excede la carga total estimada de los equipos conectados

Executive Manager Facilities Pruebas

IT Energy Cost

1642060 \$ →
Latest total Quarter Trending

IT Energy Consumption

96480 kW →
Latest average Quarter Trending

IT Energy Utilization

69.37 % →
Latest average Quarter Trending

IT Retirement Candidates

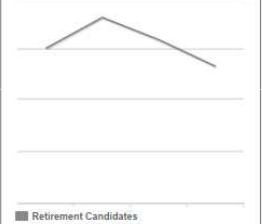

Location Map

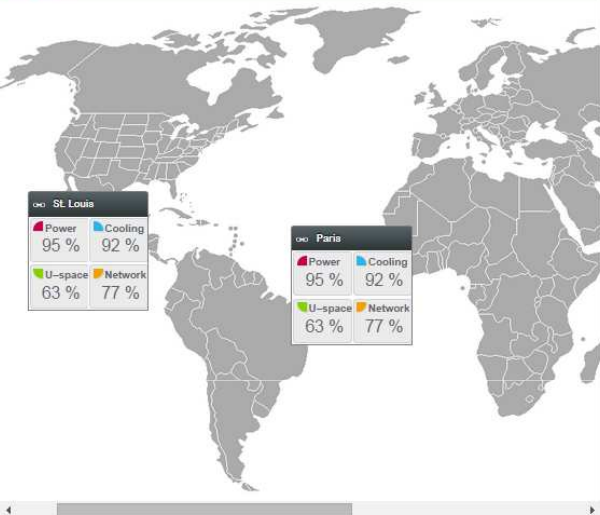

Global PUE Goal

PUE Goal 1.75

Global PUE

4.39 → ●
Latest average Year Trending Status

Capacity Overview

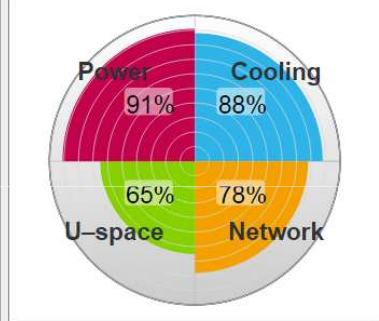

Not-delivered Work Orders

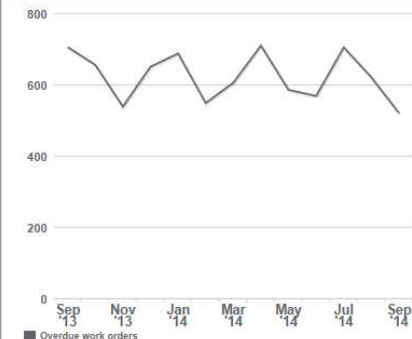

Total Work Orders



Capacity Overview

Category	Remaining	Capacity	Utilized
Power	3 Month(s)	150000 kW	91 %
Cooling	7 Month(s)	127500 kW	88 %
U-space	11 Month(s)	3817500 U-pos	65 %
Network	1 Year(s)	2936500 Por...	78 %

DCIM maturity model

Nivel 5: Auto-optimización, autónomo	Software integrado que ajusta de manera automática el rendimiento y los recursos del centro de datos de acuerdo a reglas de servicio y negocio.	0%
Nivel 4: Optimización	Integración entre subsistemas IT y Facilities; modelado de datos utilizados para predicción, gestión servicio, múltiples vistas, optimización casi en tiempo real.	<5%
Nivel 3: Proactivo	Características, localización y estado de operación de los equipos inventariado. Datos ambientales y de energía utilizados para reducir riesgos y sobredimensionamientos.	10%
Nivel 2: Reactivo	Software instalado para controlar el uso de energía de manera global y local en los equipos. Capacidad para ajustar la refrigeración a la demanda.	80%
Nivel 1: Básico	No integración; monitorización básica suministrada con equipos. Disponibilidad y seguridad.	100%

Nivel 5 – auto-optimizado

El gestor de servidores virtuales
vigila el lado IT



- PROCESADOR **insuficiente**
- MEMORIA **insuficiente**
- ALMACENAMIENTO **insuficiente**

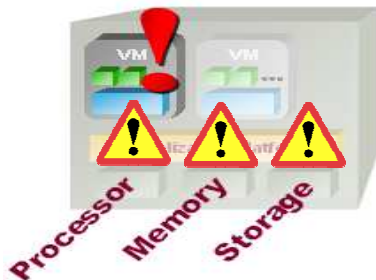

StruxureWare

vigila la infraestructura



- Corte en POWER – en **baterías, baterías bajas**
- Problema COOLING – **fallo de dispositivo con**
- Pérdida de redundancia **en power o**

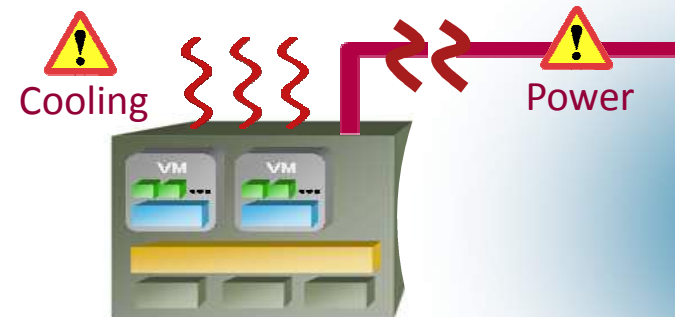

Nivel 5 – auto-optimizado

Configure la limitación de potencia

⚠ No se recomienda ajustar el valor de la limitación de potencia por debajo del 40 % de la capacidad de limitación: 3.659 W

Estrategia de limitación de potencia

- Habilitar la limitación de potencia
- Máximo de servidores simultáneos
- Máximo histórico del rack
- Recorte de máximos del rack
- Manual W

Efectos de la limitación de potencia

- Valor declarado ajustado del rack: 4.379 W
- Valor de limitación de potencia: 3.355 W
- Potencia máxima medida del rack: 3.355 W
- **Capacidad liberada:** 1.024 W
- Impacto en el rendimiento:** Bajo
- ♣ Servidores adicionales: 2

Datos históricos

Opciones avanzadas

Límite	Criticidad	Nombre	Valor declarado ajustado	Potencia máxima	Potencia media	CPU media
<input checked="" type="checkbox"/>	Media	AESXBAC1	1200 W	176 W	148 W	4%
<input type="checkbox"/>	Crítica	ProLiant DL120 G5	0 W	-	-	-
<input type="checkbox"/>	Alta	ProLiant DL120 G5	0 W	-	-	-
<input type="checkbox"/>	Media	ESBAC-FS01	1000 W	-	-	4%
<input type="checkbox"/>	Media	Sensor	500 W	-	-	-
<input type="checkbox"/>	Media	ESBAC-FS02	1000 W	-	-	4%
<input type="checkbox"/>	Media	Storageworks Msl6030 Tape Library	240 W	-	-	-
<input type="checkbox"/>	Media	AESXPOC	439 W	-	-	1%

8 de 8 elementos mostrados

Aceptar Cancelar

Nivel 5 – auto-optimizado

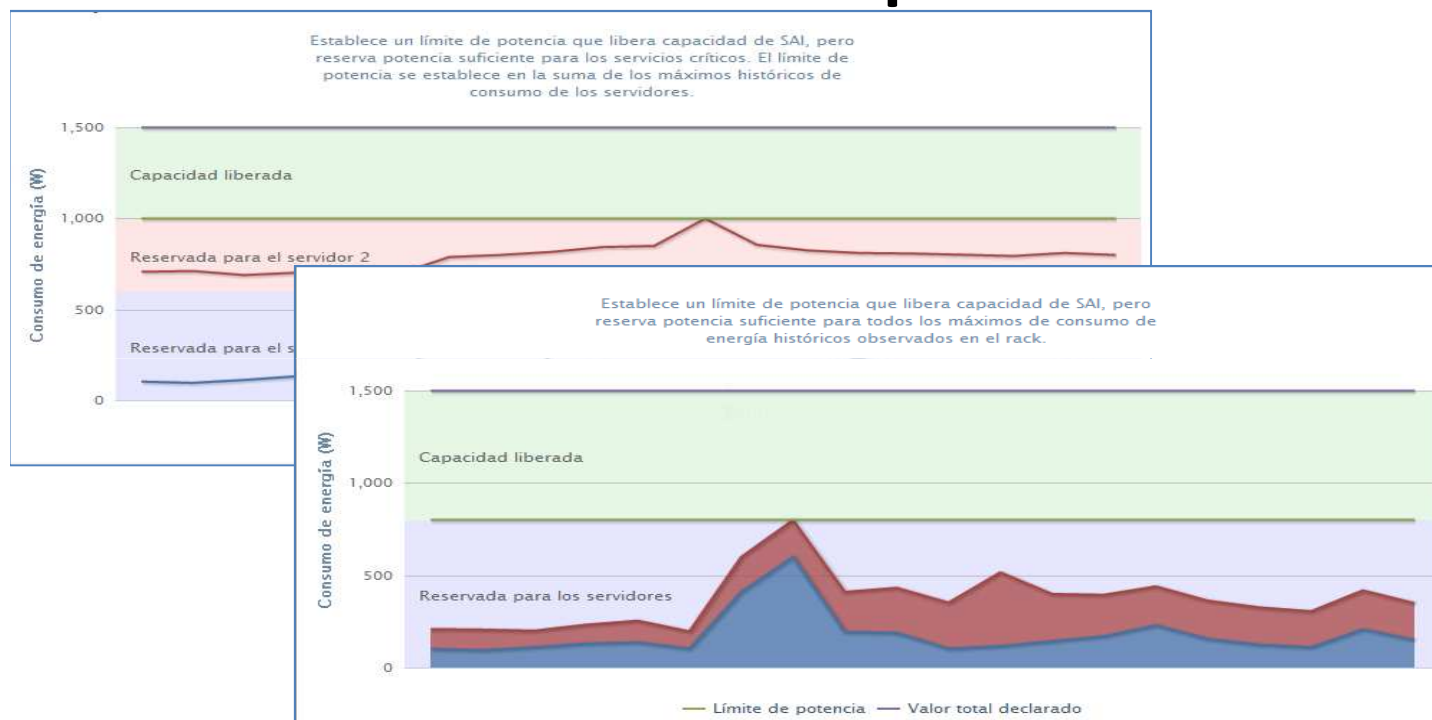

Nivel 5 – auto-optimizado

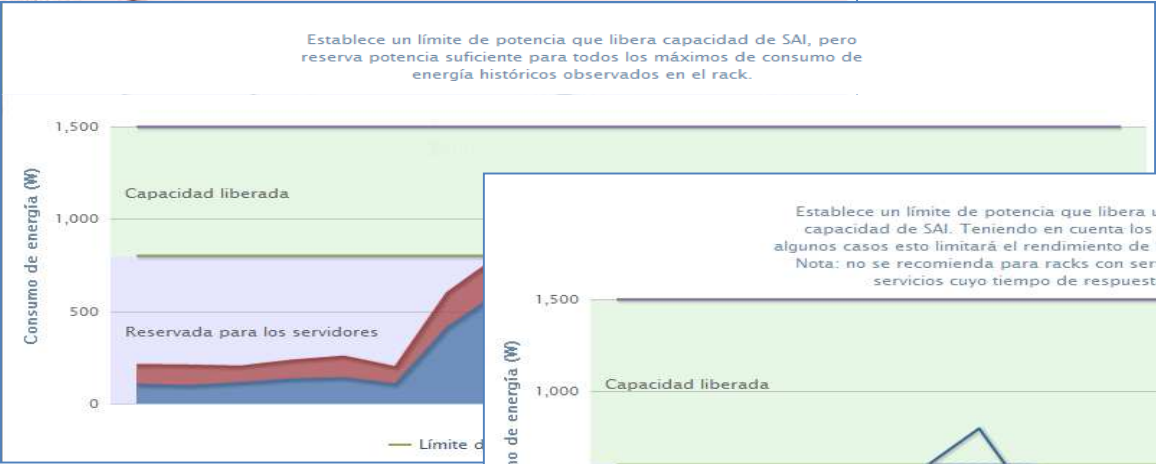
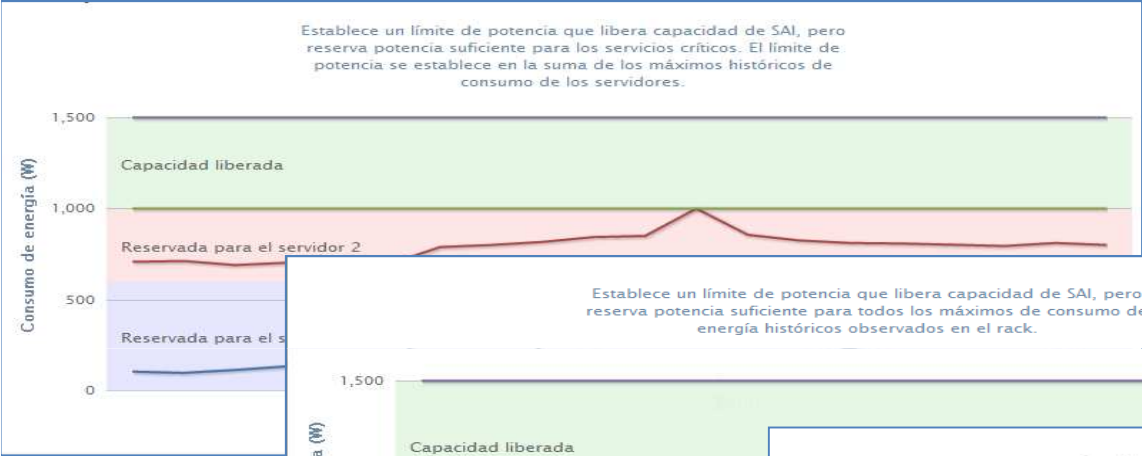

Nivel 5 – auto-optimizado



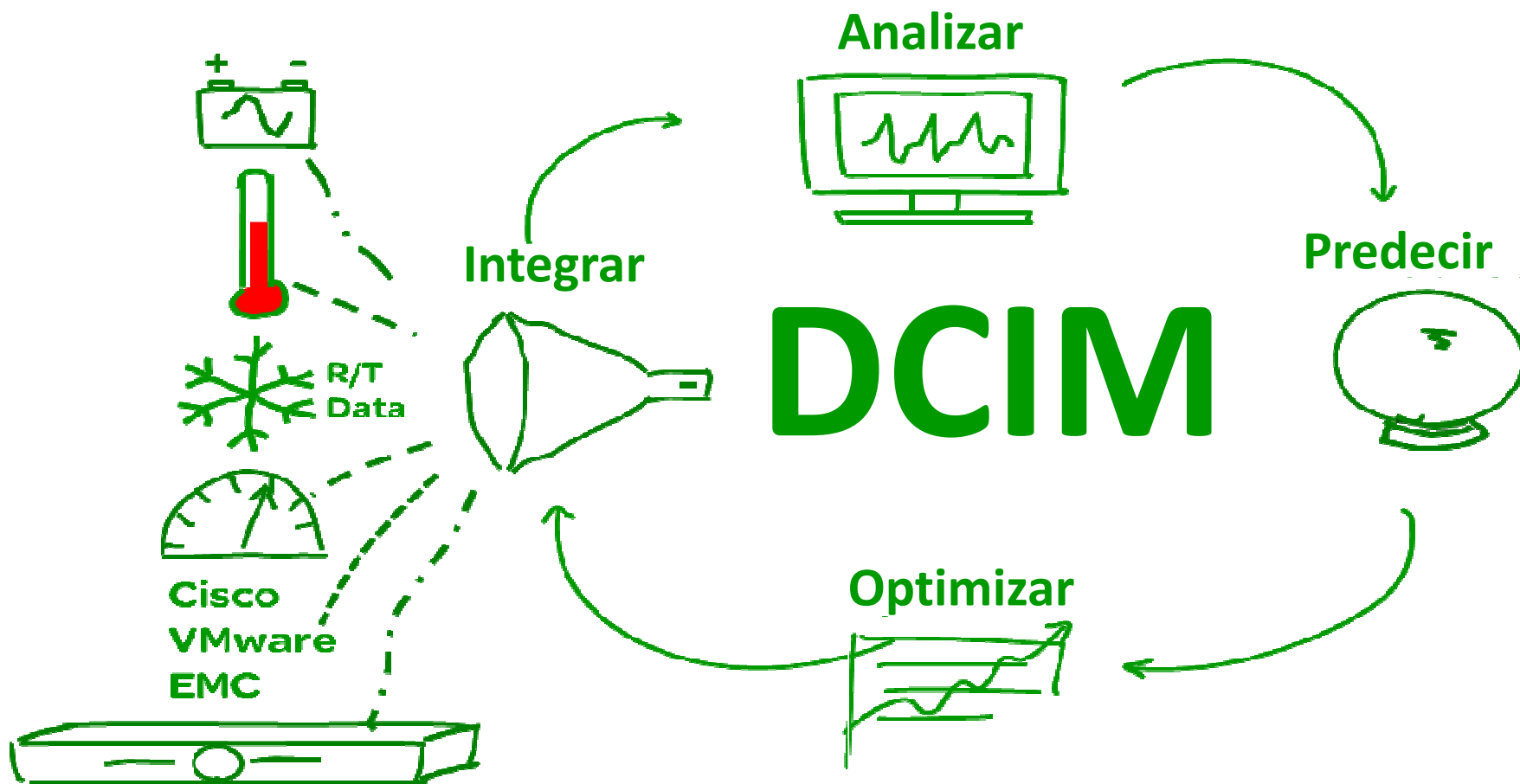

Empresas tipo DCIM

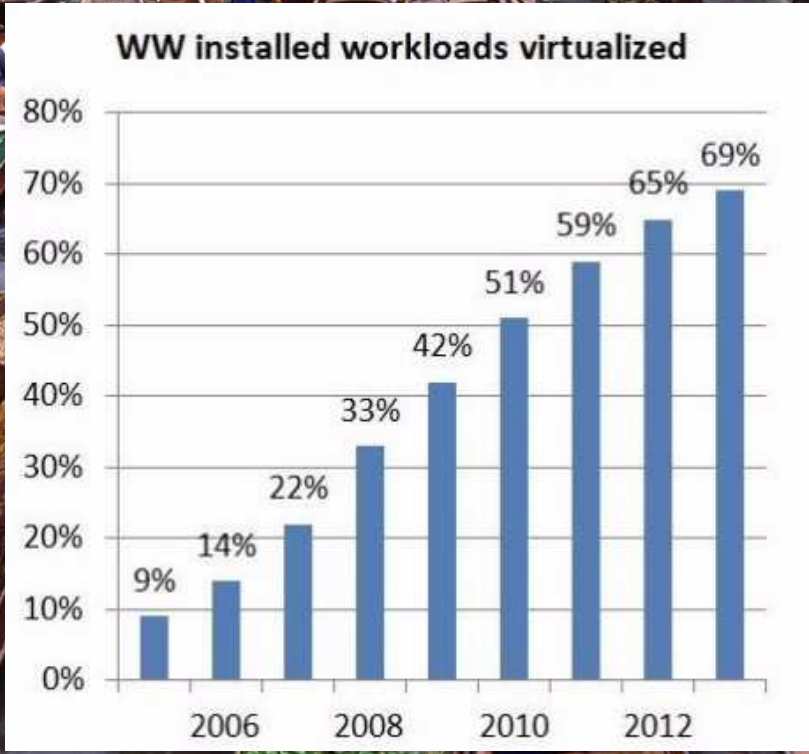
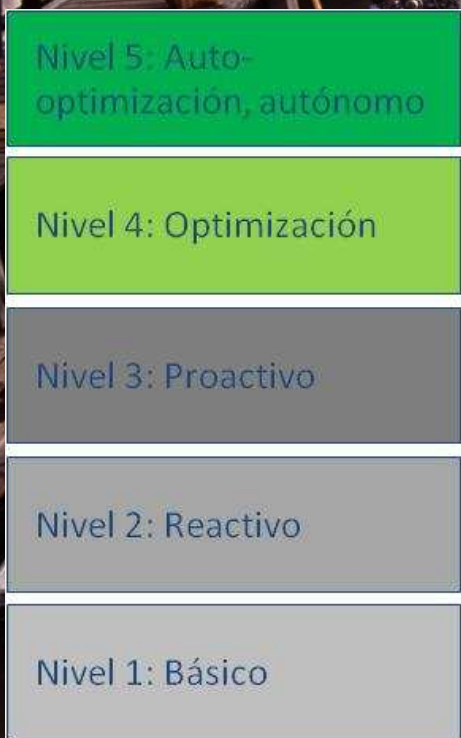

La gestión converge

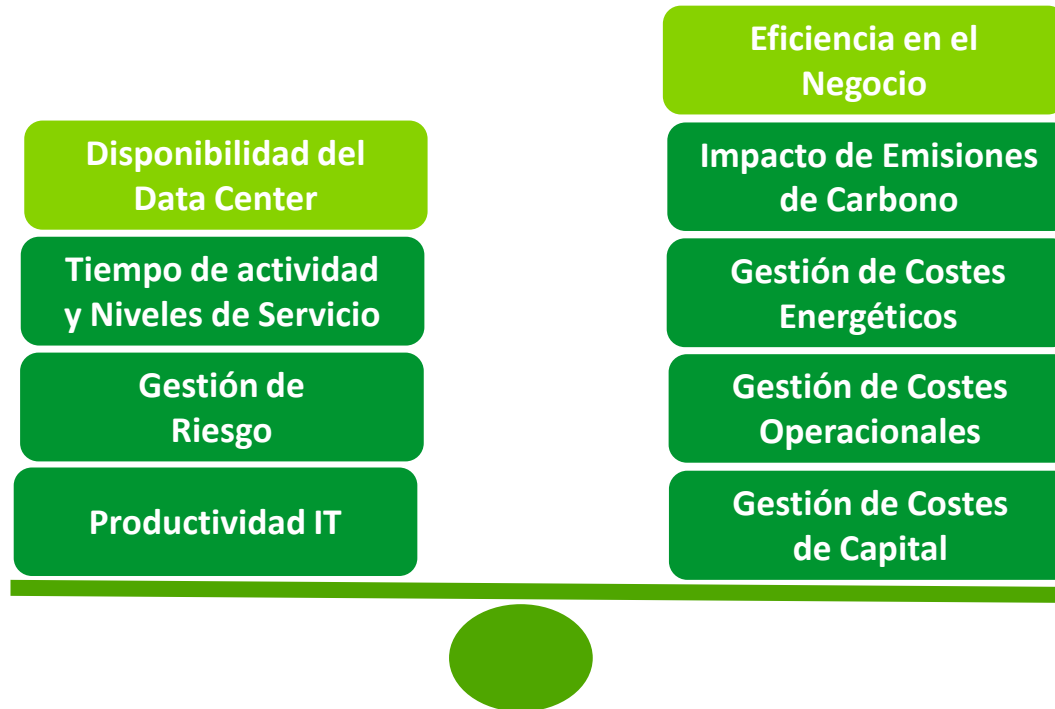

Balancear la demanda de disponibilidad y eficiencia con la flexibilidad del negocio

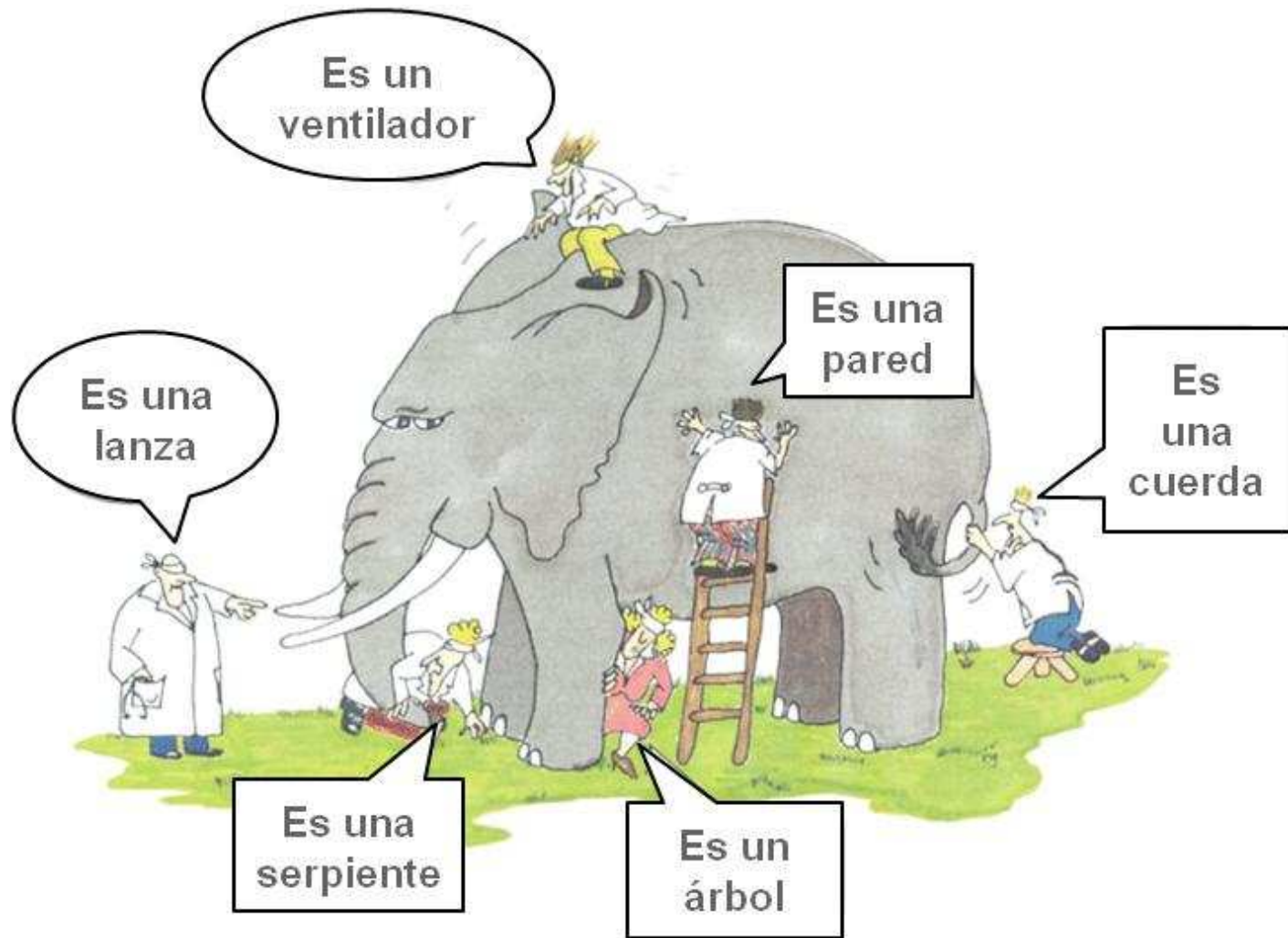

Gestión convergente

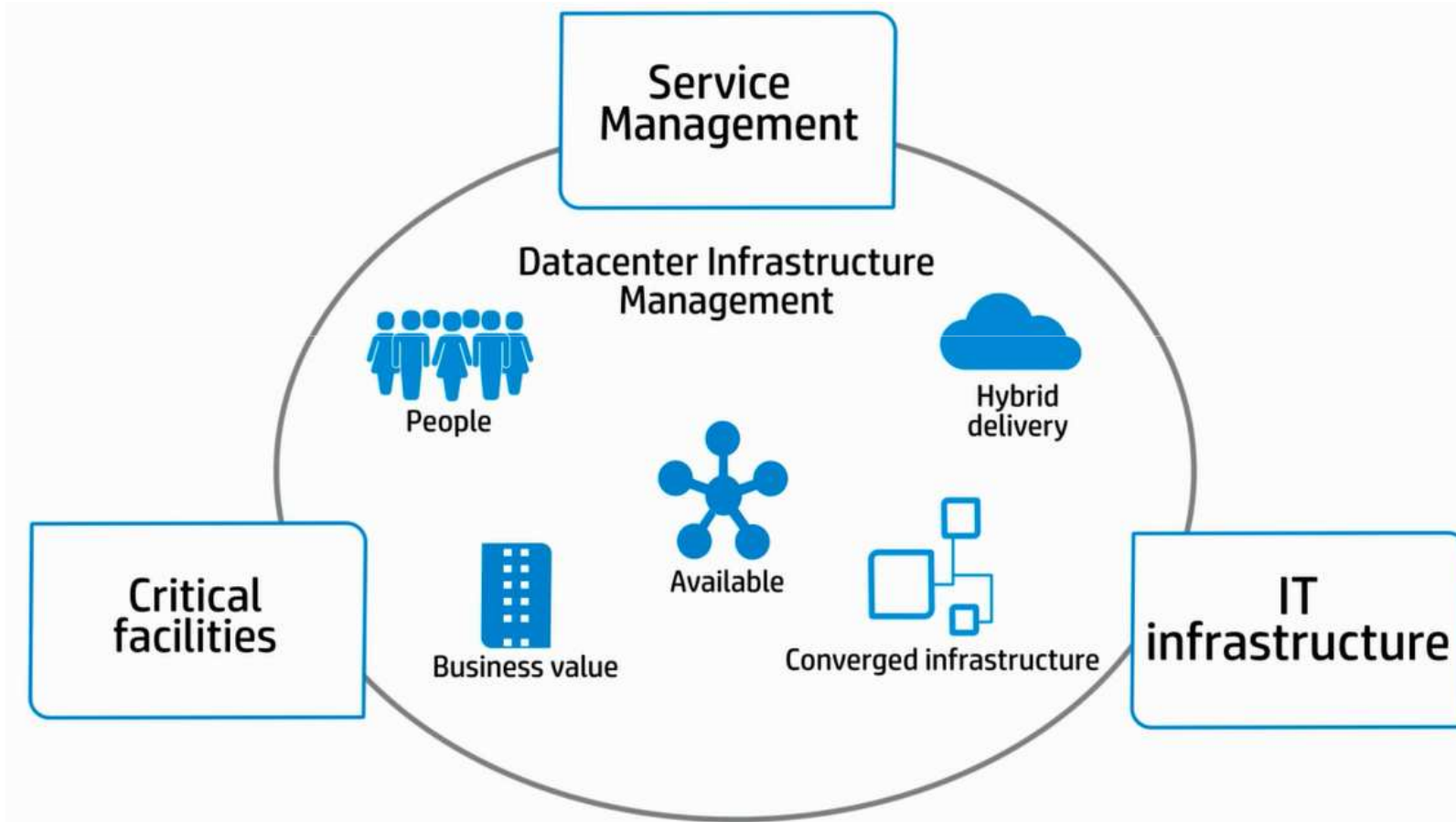

La **eficiencia operativa** se ocupa de la **minimización** de las **pérdidas** y la **maximización** de la **capacidad de los recursos**, con el fin de proveer productos y servicios de calidad a los clientes. La eficiencia operativa tiene también que ver con lo relativo al diseño de nuevos procesos de trabajo que **mejoran la calidad y la productividad**.

Personas y procesos



Eficiencia operativa



Eficiencia operativa



Tier-1 a Tier-4

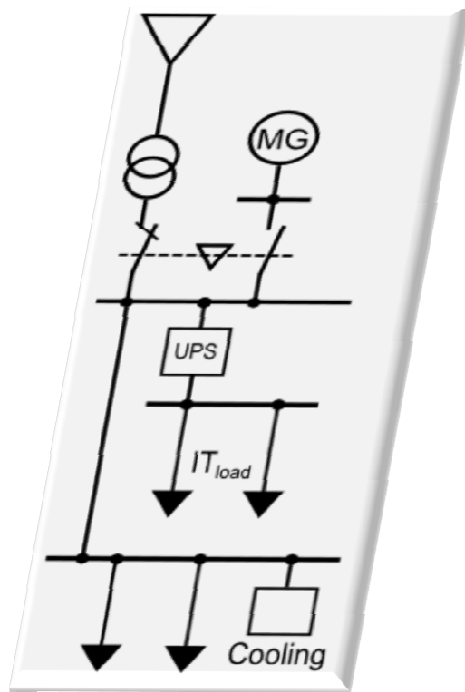

Tier-1 a Tier-4

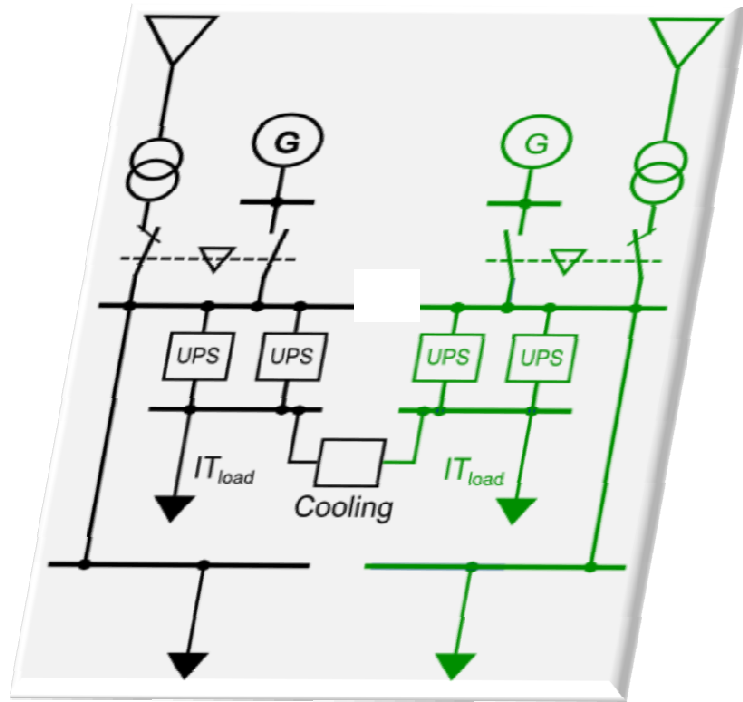

Tier-1 a Tier-4

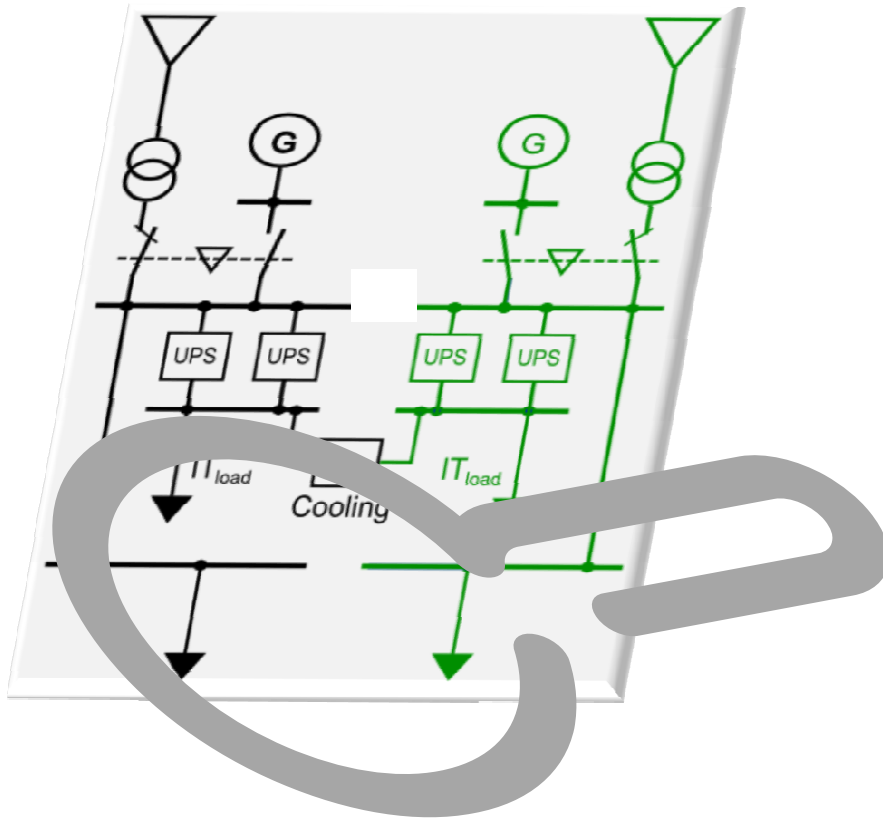

- > ¿Qué disponibilidad necesita mi IT?
- > ¿Qué redundancia tiene mi IT?
- > ¿Hemos consolidado disponibilidad y operación en fase diseño?

Gartner 2014

Cuadrante Mágico de herramientas DCIM

