

Leadership in circuit protection



EATON

Powering Business Worldwide



Energizing a world that demands more.

We deliver:

- **Electrical solutions** that use less energy, improve power reliability and make the places we live and work safer and more comfortable
- **Hydraulic and electrical solutions** that enable machines to deliver more productivity without wasting power
- **Aerospace solutions** that make aircraft lighter, safer and less costly to operate, and help airports operate more efficiently
- **Vehicle drivetrain and powertrain solutions** that deliver more power to cars, trucks and buses, while reducing fuel consumption and emissions

Discover today's Eaton.

Powering business worldwide

As a global power management company, we help customers worldwide manage the power needed for buildings, aircraft, trucks, cars, machinery and businesses.

Eaton's innovative technologies help customers manage electrical, hydraulic and mechanical power more reliably, efficiently, safely and sustainably.

We provide integrated solutions that help make energy, in all its forms, more practical and accessible.

With 2014 sales of \$22.6 billion, Eaton has approximately 100,000 employees around the world and sells products in more than 175 countries.

Eaton.com

EATON

Powering Business Worldwide

Table of contents

Section	Page
NH Fuse links technical data	4 - 11
Technical data	4 - 6
NH Fuse links applications	7
Features of the NH DIN range	8
Product range overview	9
Ordering key	9
Sizing guide	10
NH Fuse links dimensions - mm	11
400 Volts range - gG	12 - 18
Technical data	12
Catalogue numbers summary	13
Size 000	14
Size 00	15
Sizes 01 and 1	16
Sizes 02 and 2	17
Sizes 03 and 3	18
500 Volts range - gG	19 - 31
Technical data	19
Catalogue numbers summary	20 - 21
Size 000	22
Size 00	23
Size 0	24
Size 01	25
Size 1	26
Size 02	27
Size 2	28
Size 03	29
Size 3	30
Size 4	31

Section	Page
690 Volts range - gG	32 - 39
Technical data	32
Catalogue numbers summary	33
Size 000	34
Size 00	35
Size 1	36
Size 2	37
Size 3	38
Size 4	39
500 and 690 Volts range - aM	40 - 46
Technical data	40
Catalogue numbers summary	41
Size 000	42
Size 00	43
Size 1	44
Size 2	45
Size 3	46
Accessories	47 - 63
NH Fuse bases and accessories	47 - 52
NH Fuse rails - vertical	53 - 55
NH Fuse switch disconnectors - vertical	56 - 61
NH Fuse switch disconnectors - horizontal	62 - 74
Index	75 - 76

NH Fuse links technical data

Introduction

Bussmann's NH fuse link range uses the latest technology to provide class leading fuse link performance and reliable indication. With a unique patented dual indicator design capable of operating a microswitch for remote fuse indication, Bussmann provides one of the most reliable solutions available.

The range is fully compliant with IEC 60269-1 and 2 standards, with VDE 0636-2 third party approval and complies with the dimensional requirements of DIN 43620 for ease of use.

In order to help select the correct product for an application, Bussmann provides the following application notes.

Selecting the correct product

Before making a fuse link selection the following information should be known about the system or circuit to be protected.

Type of application (cable protection/motor protection)

For general applications or cable protection, the standard gG (general purpose) NH fuse link should be considered. For Motor protection applications, the aM (motor protection) NH fuse link should be considered. Motor Protection (aM) fuse links have partial range breaking ability and cannot clear low overload faults. They should only be applied to circuits also protected by a motor protection relay or where only high short-circuit faults could occur.

Note: Please note that misapplication of a fuse link can be problematical, consult Bussmann if there is any doubt over fuse link selection.

System voltage

Bussmann's NH fuse links are available in three voltage ratings, 400 V, 500 V and 690 V. These are maximum voltage ratings and should not be used where the nominal system voltage could exceed the fuse link's maximum rating.

Full load current

In accordance with IEC standards, Bussmann's NH fuse links are tested to carry full load current. The Current of a fuse link should be equal or greater than the operational current of the circuit and equal or smaller than the continuous current carrying capacity of the conductor.

The standard gG (general purpose) NH fuse link with a conventional fusing current of 1.6 times Current will give assured cable protection against the effects of overcurrents.

Non-fault overload currents (motor inrush currents etc)

To prevent nuisance operation of the fuse link, the fuse link rating selected for the application should take into account any non-fault overload currents. Please refer to the time-current curves in the catalogue.

Possible fault conditions and maximum short-circuit current

This information is essential in order to select the fuse link that would provide the best possible protection under all fault conditions. Bussmann's NH fuse links have a maximum breaking capacity of 120 kA and should never be used on a system where the maximum short-circuit current exceeds this level. Please refer to the time-current curves in the catalogue.

Time-current curves

The time-current curve is probably the most useful piece of all fuse link data available. It allows you to determine how quickly the fuse link will operate under fault conditions and which fuse link will not operate under non-fault overload currents.

To use the curve simply plot the prospective Root Mean Square (RMS) fault current along the X axis and draw a line vertically upwards from this point. Where this point intersects the fuse curve line, plot a line across to the Y axis for the relevant rating. The Y axis shows the nominal operating time for the fuse in seconds. Hence, it shows how quickly the fuse link will operate under different fault currents.

The graph can be used to check if a fuse link can withstand an overload condition that is not considered to be a fault such as a direct-on-line (DOL) motor start. For example, if a motor starts and the inrush current is six times the full load current for 10 seconds, the exact point can be plotted onto the time-current curve.

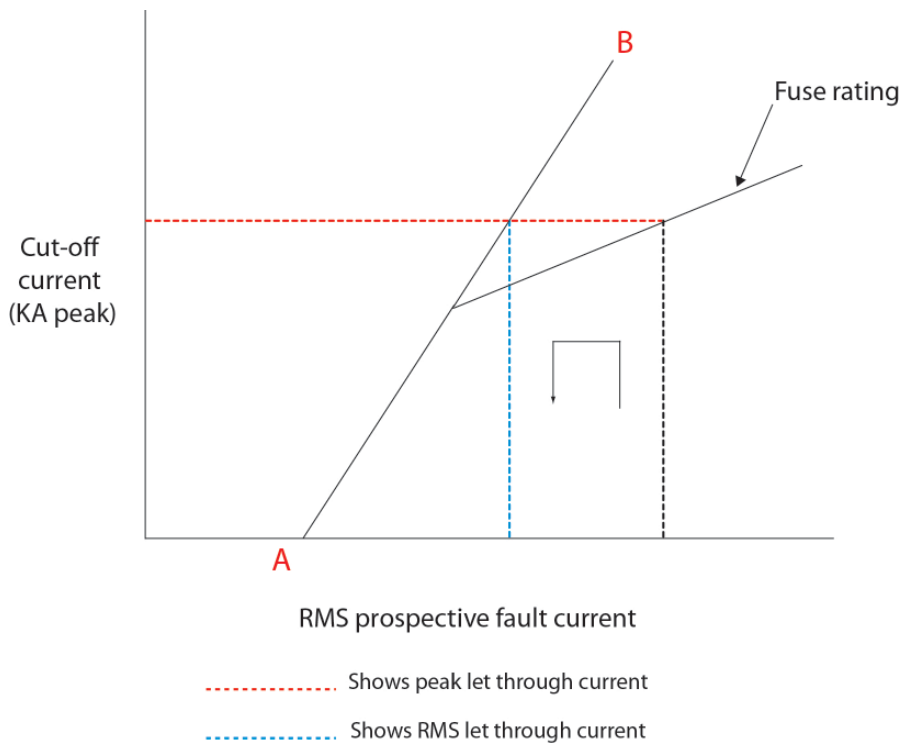

Any fuse link line lying to the right of this point will withstand the motor start current (allowing for a +/-10% tolerance on each fuse link curve). If the fuse link curve falls to the left of this point, then the fuse link will not withstand the motor start current and will inadvertently operate when the motor is started.

In summary, the rule for time-current curves is that any point on or to the right of a fuse link curve would indicate the fuse link has operated in the given time. Any point to the left of the curve would indicate the fuse link has not operated.

Cut-off curves

The graph consists of an A-B line running diagonally from bottom left to top right, see drawing below. This is known as the non current-limiting line. Branching from this A-B line you can see each individual fuse link rating line running diagonally left to right. To read the graph, plot the RMS prospective fault current along the X axis. If this point only intersects the A-B line then the prospective fault current is too low to benefit from the current-limiting effect of the fuse link.

However, if this point intersects the relevant fuse link line, plot a line across to the Y axis. This point on the Y axis shows the peak asymmetrical let-through current the fuse link will allow to pass before operating. The peak asymmetrical let-through current is the absolute worst case peak current the fuse link will allow to pass through, taking into account the DC offset seen under short-circuit conditions and low power factor.

The RMS let-through current is read from the graph using the same procedure above. Instead of plotting the point of intersection with the fuse link current-limiting line over to the Y axis, it should only be plotted as far as the A-B line. At this point, a line can be drawn back down to the X axis to show a RMS symmetrical value of let-through current. This is known as the "up, over and down method".

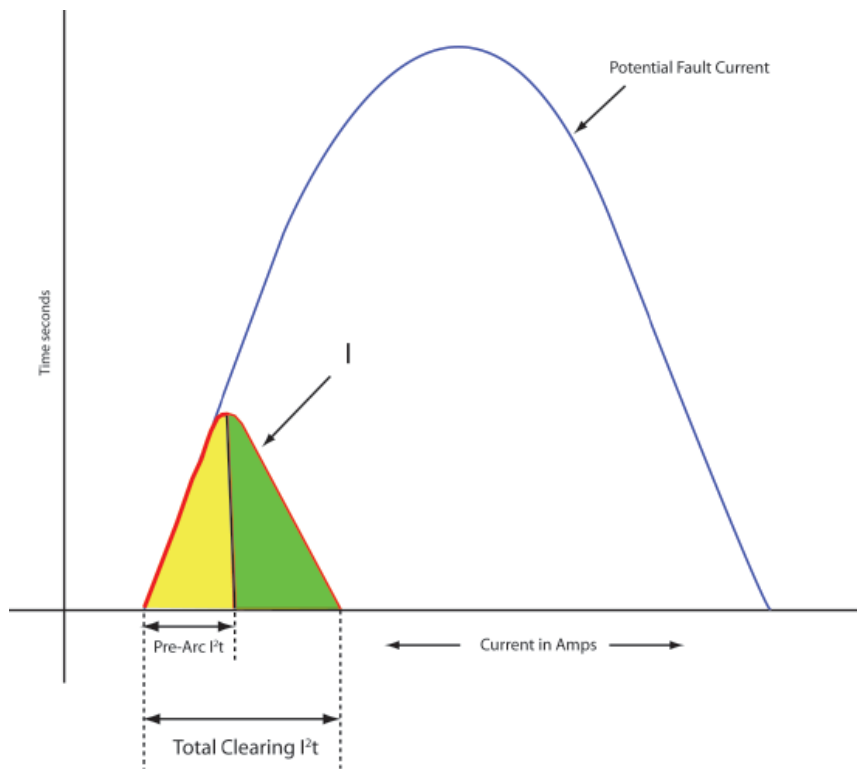

I²t values

I²t values are measured at the time of testing the fuse link at their rated breaking capacity and voltage. I²t is effectively the amount of heating energy the fuse link will allow to pass during fault clearing at high short-circuit faults. I²t values relevant for short-circuit faults cannot be calculated from the time-current or cut-off curves.

The published I²t figures always show two values, pre-arcing/total clearing and are representative of the area under the first half cycle of the fault current.

- The pre-arcing value is the area under the first half cycle of fault current showing on the graph in yellow to the point just before an arc occurs within the fuse link. This is due to the element material being vaporised by the very high short-circuit current.
- The total clearing I²t is the yellow and green area under the first half cycle from the start of the short-circuit current flow to the point where the fuse link has become an insulator, completely isolating the flow of current.

The diagram here shows a representation of I²t during a half cycle of fault current.

I²t values give a good representation of the speed of operation of a fuse link. A small I²t value would indicate a very fast-acting fuse link whereas a large I²t value would indicate a fairly slow operating fuse link. In all cases the total clearing I²t value of the fuse link must be smaller than the I²t value of the device to be protected in order for the fuse link to provide adequate protection against short-circuit faults. For fuse link discrimination (see definition of discrimination below) in distribution systems, the total clearing I²t value of the fuse link downstream should be less than the pre-arc-

ing I²t value of the fuse link upstream. This ensures the smaller fuse link, in the system operates well before the larger upstream fuse link.

NH discrimination

Bussmann's NH fuse links are easy to use on distribution networks where discrimination between large and small fuse links are required. This can be achieved by applying a discrimination factor of 1 to 1.6 without the need to check the fuse link data. For example, by using a 100 A fuse link downstream from the main 160A fuse link, in the event of a fault condition, the smaller 100A fuse link is sure to operate before the 160A fuse link, ensuring discrimination.

DC applications

Bussmann's NH fuse links can be used on DC applications. In all cases the fuse links can be used at half of their AC rating with a time constant of no more than 10mS. The time constant is the rate of rise of fault current and should be as close to a 50Hz AC half cycle as possible.

Power loss

Every effort is made to ensure the power loss of the fuse link is kept to a minimum. Bussmann provides fuse links with some of the lowest power losses in the industry. Power loss of the fuse link is given off as heat and this should be taken into account when fitting fuse links into unventilated areas. It is preferable that a fuse link has good airflow around the body of the fuse link to ensure cool running and prevent nuisance operation of the fuse link due to thermal stresses.

NH Fuse links applications

Solar applications



NH fuse links can be found on a solar distribution network

Wind applications



NH fuse links can be found in a wind turbine



Utilities applications



NH fuse links can be found on the low voltage side of substations

Industrial applications



NH fuse links can be used for protection of cables and distribution circuits

Motor applications



NH fuse links can be used for industrial motor applications

NH Dual indicator system from Bussmann

- High breaking capacity
- 400, 500 and 690 V a.c.
- Dual indication
- Insulated tag variants option available
- IEC 60269-1 and 2, DIN 43620, VDE 0636-2, CE Mark.

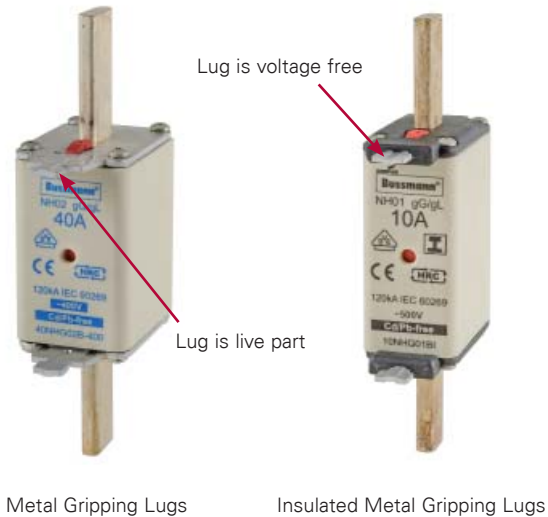

Features of the NH DIN range

Dual indicator system

Bussmann's patented dual indicator provides clear indication, ensuring extremely reliable local and remote* signalling, decreasing fuse link replacement time and costs.

* with the use of an optional microswitch accessory



Low power loss

Bussmann's "low watts loss" fuse links reduce overall operating costs and carbon footprint through lower energy consumption and heat transfer to equipment. To find out how much you can save, please contact our technical applications department: buletechnical@eaton.com.



Globally compliant

Bussmann's NH fuse links are tested and comply with IEC 60269-1 and 2, DIN 43620, VDE, CE, CCC (China), RoHS and can be recycled, ensuring global acceptance.



Lead and cadmium free

Bussmann is the world's first true manufacturer of a complete range of Lead and Cadmium free NH fuse links. Negating any legislation concerns regarding the amount of hazardous materials permissible within the fuse links.



Recycling

Bussmann is dedicated to produce recyclable products and is a member of an industry recognised recycling scheme. The "HRC" symbol on Bussmann's NH fuse links define the product suitable for recycling, limiting disposal cost.



Sizing guide

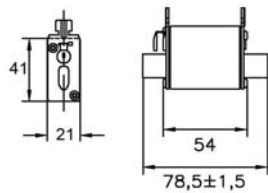

Size 000

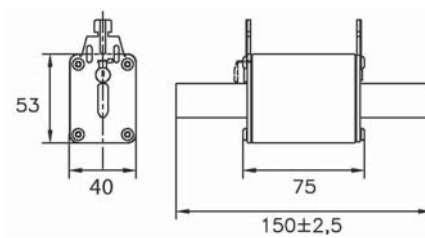

Size 02

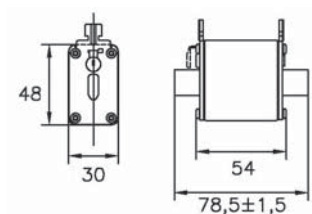

Size 00

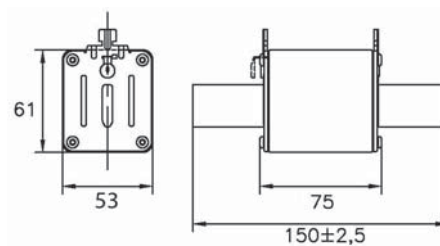

Size 2

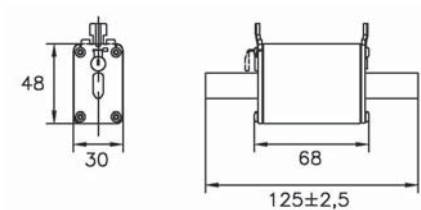

Size 0

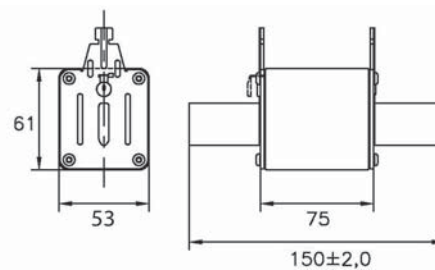

Size 03

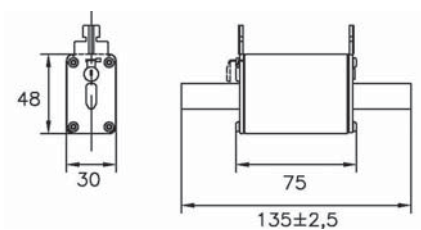

Size 01

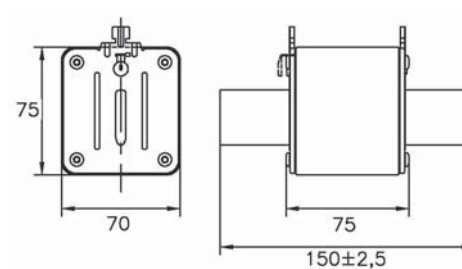

Size 3

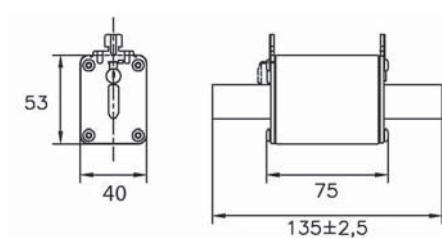

Size 1

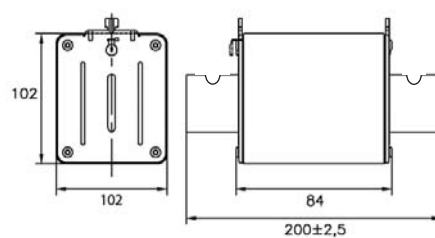

Size 4

NH Fuse links dimensions - mm

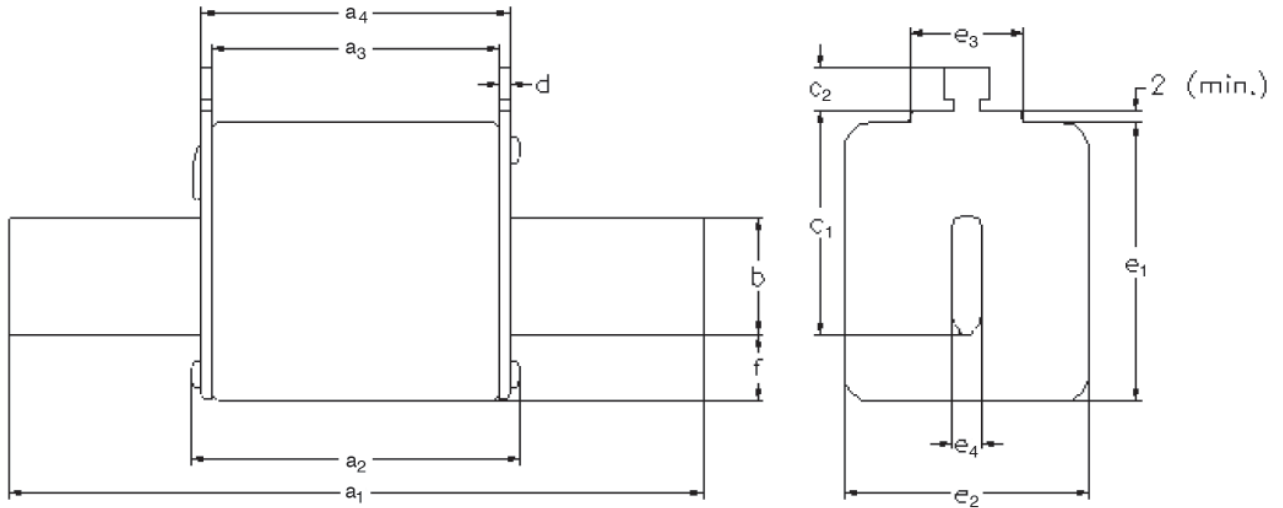

Size	a_1	a_2 (max)	a_3	a_4	b	c_1	c_2	d	e_1 (max)	e_2 (max)	e_3 (max)	e_4	f (max)
000	78.5±1.5	54	45±1.5	49±1.5	15	35	10	2±0.5	41	21	16	6	8
00	78.5±1.5	54	45±1.5	49±1.5	15	35	11	2±0.5	48	30	25	6	15
0	125±2.5	68	62 ⁺³ _{-1.5}	68 ^{+1.5} ₋₃	15	35	11	2.5±0.5	48	30	25	6	15
01	135±2.5	75	62±2.5	68±2.5	15	40	11	2.5±0.5	48	30	25	6	15
1	135±2.5	75	62±2.5	68±2.5	20	40	11	2.5±0.5	53	40	25	6	15
02	150±2.5	75	62±2.5	68±2.5	20	48	11	2.5±0.5	53	40	25	6	15
2	150±2.5	75	62±2.5	68±2.5	25	48	11	2.5±0.5	61	53	25	6	15
03	150±2.5	75	62±2.5	68±2.5	25	60	11	2.5±0.5	61	53	25	6	15
3	150±2.5	75	62±2.5	68±2.5	32	60	11	3±0.5	75	70	25	6	18
4*	200±3	84	62±2.5	90±3	50	85	10	3±0.5	102	102	25	8	30

* Size 4 is a single indication fuse link with slotted end tags

400 V a.c. - class gG/gL - 2 to 630 amps - sizes 000 to 3

400Vac

Description

A square bodied range of industrial fuse links for a wide variety of applications.

Catalogue numbers structure

- (amp)NHG(size)B-400 e.g. 100NHG02B-400 with conducting metal gripping lugs
- (amp)NHG(size)BI-400 e.g. 100NHG000BI-400 with insulated metal gripping lugs

Class of operation

- gL/gG.

Standards / approvals

- IEC 60269-1 and 2, VDE 0636, DIN 43620 and CE.

Technical data

- Sizes 000 to 3
- Voltage: 400 V a.c.
- Current: 2 to 630 A
- Rated breaking capacity: 120 kA AC
- Rated frequency: 50Hz
- Operating frequency: 45-62Hz.

Optional microswitch

- BVL50 or 170H0236.

Compatible fuse holders

- Fuse bases 1 pole:
 - SD(size)-D DIN-Rail mounted
 - SD(size)-S: Screw mounting
- Fuse bases 3 pole
 - TD(size)-D, DIN-Rail mounted
- Fuse bases accessories: IP20, shroud and phase barrier kits
- Fuse rails - vertical: EBF series
- Fuse switch disconnectors vertical: EBV series
- Fuse switch disconnectors horizontal: EBH series.

Environmental

- Recyclable
- RoHS compliant
- Lead and cadmium free.

Packaging

- All fuse links are packed in threes.

Features:

- Reliable dual indicator system
- Low temperature rise
- Globally compliant.



400 V a.c. - class gG/gL - 2 to 630 amps - sizes 000 to 3

Catalogue Numbers								
Size	Current (Amps)	Voltage (V a.c.)	gG/gL Dual Indicator		Pack Quantity			
			Voltage Conducting Metal Gripping Lugs	Insulated Metal Gripping Lugs				
000	2	400	2NHG000B-400	2NHG000BI-400	3			
	4		4NHG000B-400	4NHG000BI-400				
	6		6NHG000B-400	6NHG000BI-400				
	10		10NHG000B-400	10NHG000BI-400				
	16		16NHG000B-400	16NHG000BI-400				
	20		20NHG000B-400	20NHG000BI-400				
	25		25NHG000B-400	25NHG000BI-400				
	32		32NHG000B-400	32NHG000BI-400				
	35		35NHG000B-400	35NHG000BI-400				
	40		40NHG000B-400	40NHG000BI-400				
	50		50NHG000B-400	50NHG000BI-400				
00	125	400	125NHG00B-400	125NHG00BI-400	3			
	160		160NHG00B-400	160NHG00BI-400				
	01		35	400		35NHG01B-400	35NHG01BI-400	3
			40			40NHG01B-400	40NHG01BI-400	
50		50NHG01B-400	50NHG01BI-400					
63		63NHG01B-400	63NHG01BI-400					
80		80NHG01B-400	80NHG01BI-400					
100		100NHG01B-400	100NHG01BI-400					
125		125NHG01B-400	125NHG01BI-400					
1	200	400	200NHG1B-400	200NHG1BI-400	3			
	224		224NHG1B-400	224NHG1BI-400				
	250		250NHG1B-400	250NHG1BI-400				
02	35	400	35NHG02B-400	35NHG02BI-400	3			
	40		40NHG02B-400	40NHG02BI-400				
	50		50NHG02B-400	50NHG02BI-400				
	63		63NHG02B-400	63NHG02BI-400				
	80		80NHG02B-400	80NHG02BI-400				
	100		100NHG02B-400	100NHG02BI-400				
	125		125NHG02B-400	125NHG02BI-400				
	160		160NHG02B-400	160NHG02BI-400				
	200		200NHG02B-400	200NHG02BI-400				
	224		224NHG02B-400	224NHG02BI-400				
	250		250NHG02B-400	250NHG02BI-400				
2	315	400	315NHG2B-400	315NHG2BI-400	3			
	355		355NHG2B-400	355NHG2BI-400				
	400		400NHG2B-400	400NHG2BI-400				
	630		630NHG2B-400	-				
03	250	400	250NHG03B-400	250NHG03BI-400	3			
	315		315NHG03B-400	315NHG03BI-400				
	355		355NHG03B-400	355NHG03BI-400				
	400		400NHG03B-400	400NHG03BI-400				
3	500	400	500NHG3B-400	500NHG3BI-400	3			
	630		630NHG3B-400	630NHG3BI-400				



400Vac

400 V a.c. - class gG/gL - 2 to 100 amps - size 000

Time-current characteristics

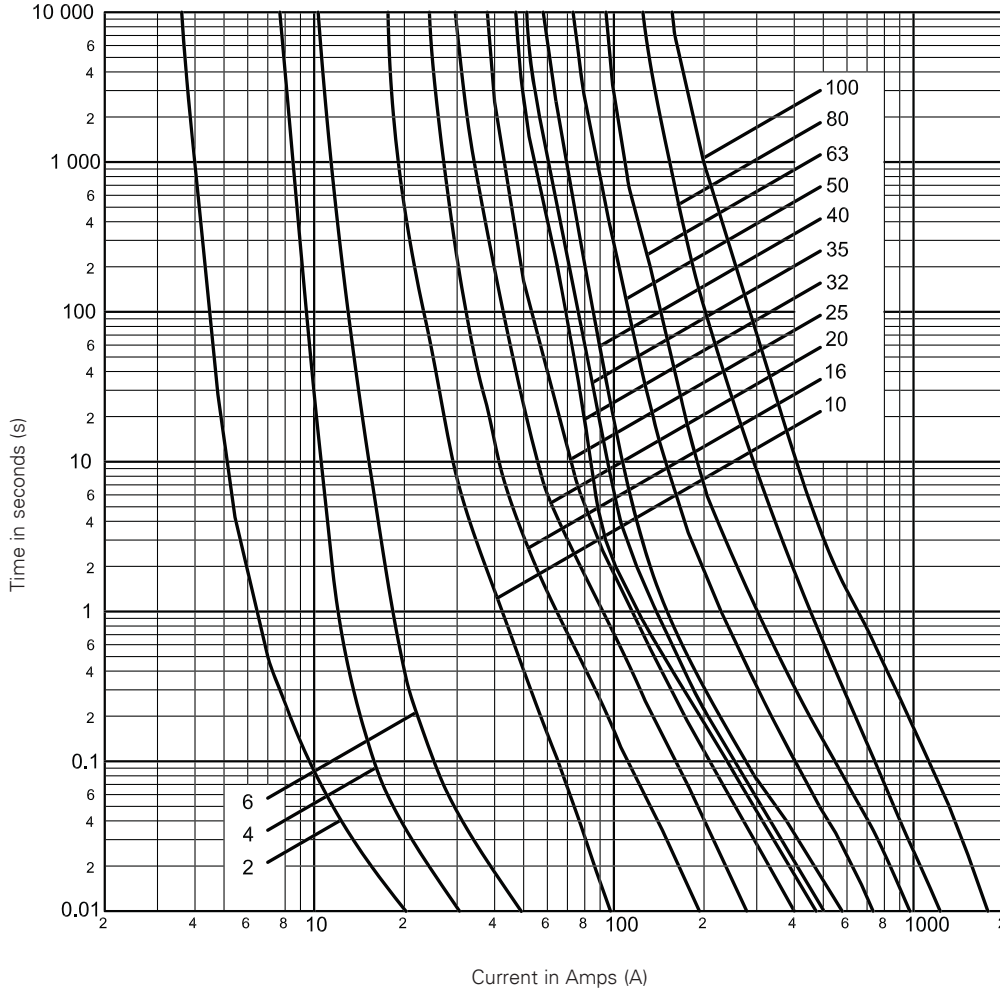

Technical data

Catalogue Numbers With Metal Gripping Lugs	Catalogue Numbers With Insulated Metal Gripping Lugs	Fuse Link Size	Current (Amps)	Voltage (V a.c.)	I ² t (Amps ² Seconds)		Watts Loss (W)	Net Weight Per Fuse (Kg)
					Minimum Pre-Arcing	*I ₁ , 120 kA at 400 V a.c.		
2NHG000B-400	2NHG000BI-400	000	2	400	3.5	5.5	0.8	0.133
4NHG000B-400	4NHG000BI-400		4		6	10.5	1.4	
6NHG000B-400	6NHG000BI-400		6		14	19	2.2	
10NHG000B-400	10NHG000BI-400		10		60	175	1.5	
16NHG000B-400	16NHG000BI-400		16		240	710	2.3	
20NHG000B-400	20NHG000BI-400		20		584	1800	2.2	
25NHG000B-400	25NHG000BI-400		25		1000	2800	3.1	
32NHG000B-400	32NHG000BI-400		32		2400	9600	2.8	
35NHG000B-400	35NHG000BI-400		35		2900	11,300	2.8	
40NHG000B-400	40NHG000BI-400		40		4000	16,400	3	
50NHG000B-400	50NHG000BI-400		50		4000	12,000	3.4	
63NHG000B-400	63NHG000BI-400		63		6000	20,400	4.5	
80NHG000B-400	80NHG000BI-400		80		9900	35,700	4.7	
100NHG000B-400	100NHG000BI-400		100		18,100	39,800	5.2	

* I₁ is the maximum breaking capacity test at Voltage according to IEC 60269-1 and 2 requirements

400 V a.c. - class gG/gL - 125 and 160 amps - size 00

Time-current characteristics

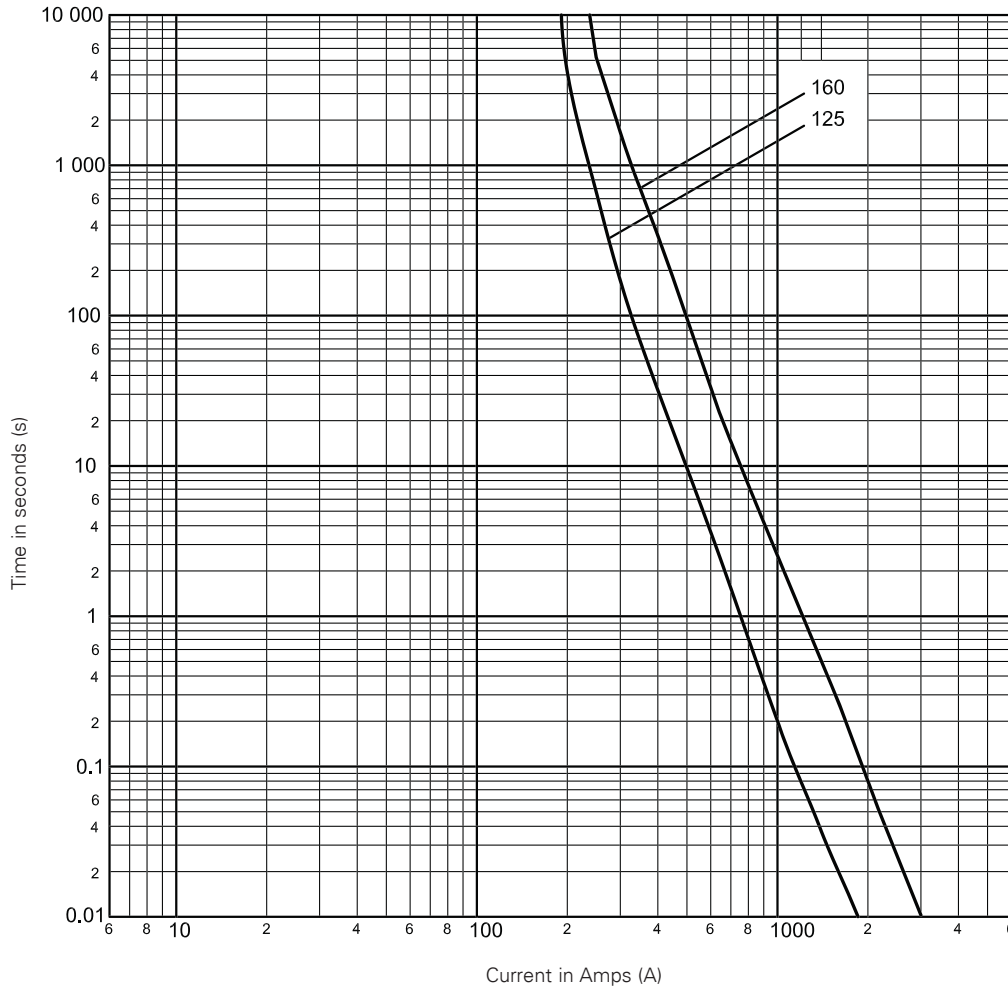

400Vac

Technical data

Catalogue Numbers With Metal Gripping Lugs	Catalogue Numbers With Insulated Metal Gripping Lugs	Fuse Link Size	Current (Amps)	Voltage (V a.c.)	I²t (Amps² Seconds)		Watts Loss (W)	Net Weight Per Fuse (Kg)
					Minimum Pre-Arcing	*I ₁ 120 kA at 400 V a.c.		
125NHG00B-400	125NHG00BI-400	00	125	400	25,000	80,000	8	0.185
160NHG00B-400	160NHG00BI-400		160		60,000	126,000	7.8	

* I₁ is the maximum breaking capacity test at Voltage according to IEC 60269-1 and 2 requirements

400 V a.c. - class gG/gL - 35 to 250 amps - sizes 01 & 1

Time-current characteristics

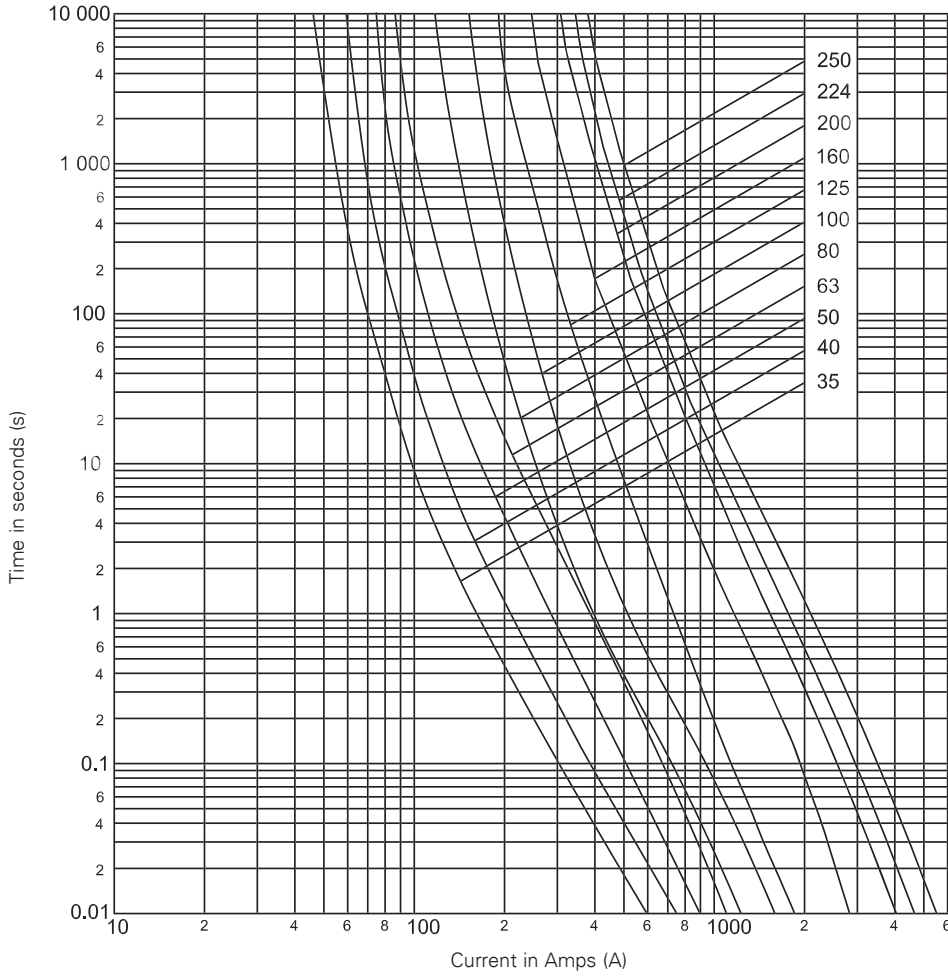

Technical data

Catalogue Numbers With Metal Gripping Lugs	Catalogue Numbers With Insulated Metal Gripping Lugs	Fuse Link Size	Current (Amps)	Voltage (V a.c.)	I ² t (Amps ² Seconds)		Watts Loss (W)	Net Weight Per Fuse (Kg)		
					Minimum Pre-Arcing	*I ₁ , 120 kA at 400 V a.c.				
35NHG01B-400	35NHG01BI-400	01	35	400	2400	7600	4.9	0.269		
40NHG01B-400	40NHG01BI-400		40		3300	10,600	5			
50NHG01B-400	50NHG01BI-400		50		4200	10,400	4.7			
63NHG01B-400	63NHG01BI-400		63		6600	16,300	5.6			
80NHG01B-400	80NHG01BI-400		80		9600	33,600	5.6			
100NHG01B-400	100NHG01BI-400		100		16,000	56,000	6.8			
125NHG01B-400	125NHG01BI-400		125		24,000	86,400	8.8			
160NHG01B-400	160NHG01BI-400		160		53,000	111,300	8.9			
200NHG1B-400	200NHG1BI-400		1		200	89,000	232,000		12	0.387
224NHG1B-400	224NHG1BI-400				224	119,000	322,000		12	
250NHG1B-400	250NHG1BI-400	250		171,000	479,000	14				

* I₁ is the maximum breaking capacity test at Voltage according to IEC 60269-1 and 2 requirements

400 V a.c. - class gG/gL - 35 to 630 amps - sizes 02 & 2

Time-current characteristics

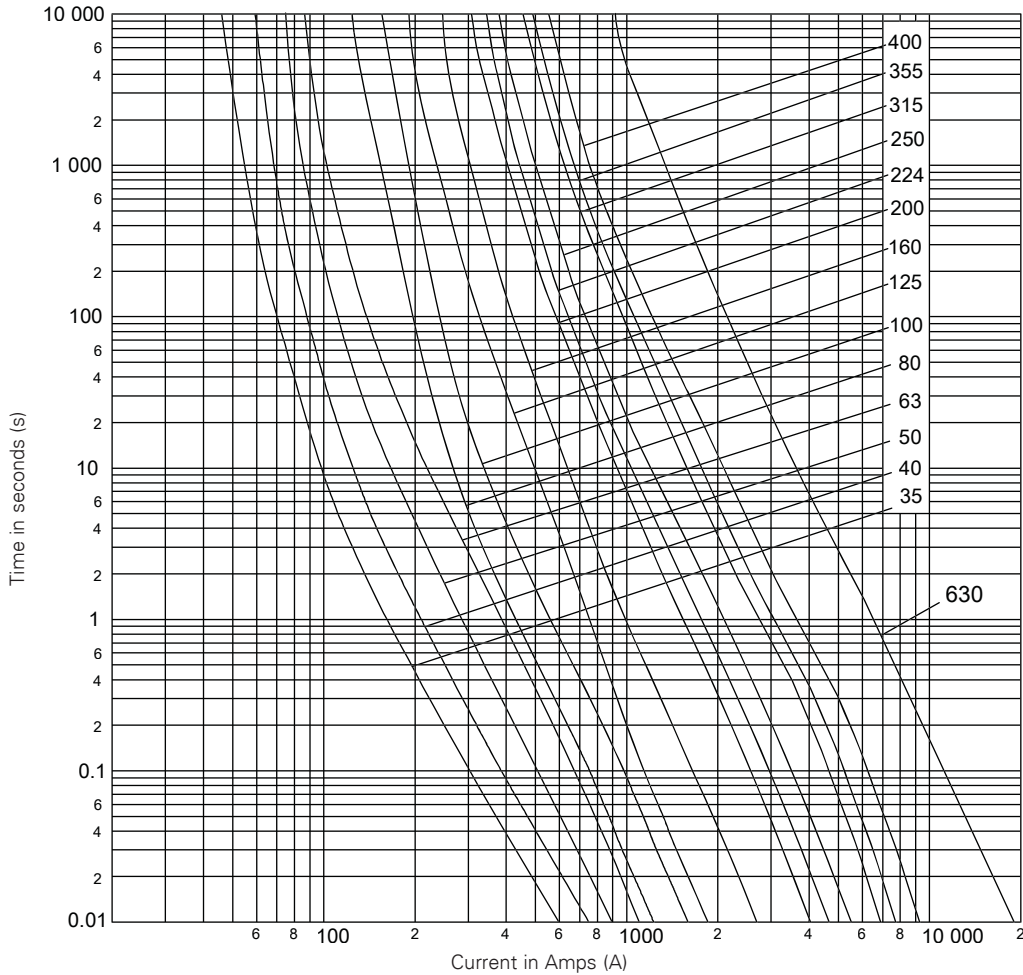

400Vac

Technical data

Catalogue Numbers With Metal Gripping Lugs	Catalogue Numbers With Insulated Metal Gripping Lugs	Fuse Link Size	Current (Amps)	Voltage (V a.c.)	I ² t (Amps ² Seconds)		Watts Loss (W)	Net Weight Per Fuse (Kg)
					Minimum Pre-Arcing	*I ₁ 120 kA at 400 V a.c.		
35NHG02B-400	35NHG02BI-400	02	35	400	2400	7600	4.4	0.402
40NHG02B-400	40NHG02BI-400		40		3300	10,600	5	
50NHG02B-400	50NHG02BI-400		50		4200	10,400	6.5	
63NHG02B-400	63NHG02BI-400		63		6600	16,300	5.5	
80NHG02B-400	80NHG02BI-400		80		10,000	34,800	5.5	
100NHG02B-400	100NHG02BI-400		100		16,000	56,000	6.6	
125NHG02B-400	125NHG02BI-400		125		24,000	86,400	8.7	
160NHG02B-400	160NHG02BI-400		160		50,000	185,000	10	
200NHG02B-400	200NHG02BI-400		200		89,000	232,000	12	
224NHG02B-400	224NHG02BI-400		224		119,000	322,000	12	
250NHG02B-400	250NHG02BI-400	250	171,000	479,000	14			
315NHG2B-400	315NHG2BI-400	2	315	400	280,000	924,000	19	0.630
355NHG2B-400	355NHG2BI-400		355		350,000	1,155,000	22	
400NHG2B-400	400NHG2BI-400		400		504,000	1,673,000	24	
630NHG2B-400	-		630		2,100,000	5,775,000	44	

* I₁ is the maximum breaking capacity test at Voltage according to IEC 60269-1 and 2 requirements

400 V a.c. - class gG/gL - 250 to 630 amps - sizes 03 & 3

Time-current characteristics

400Vac

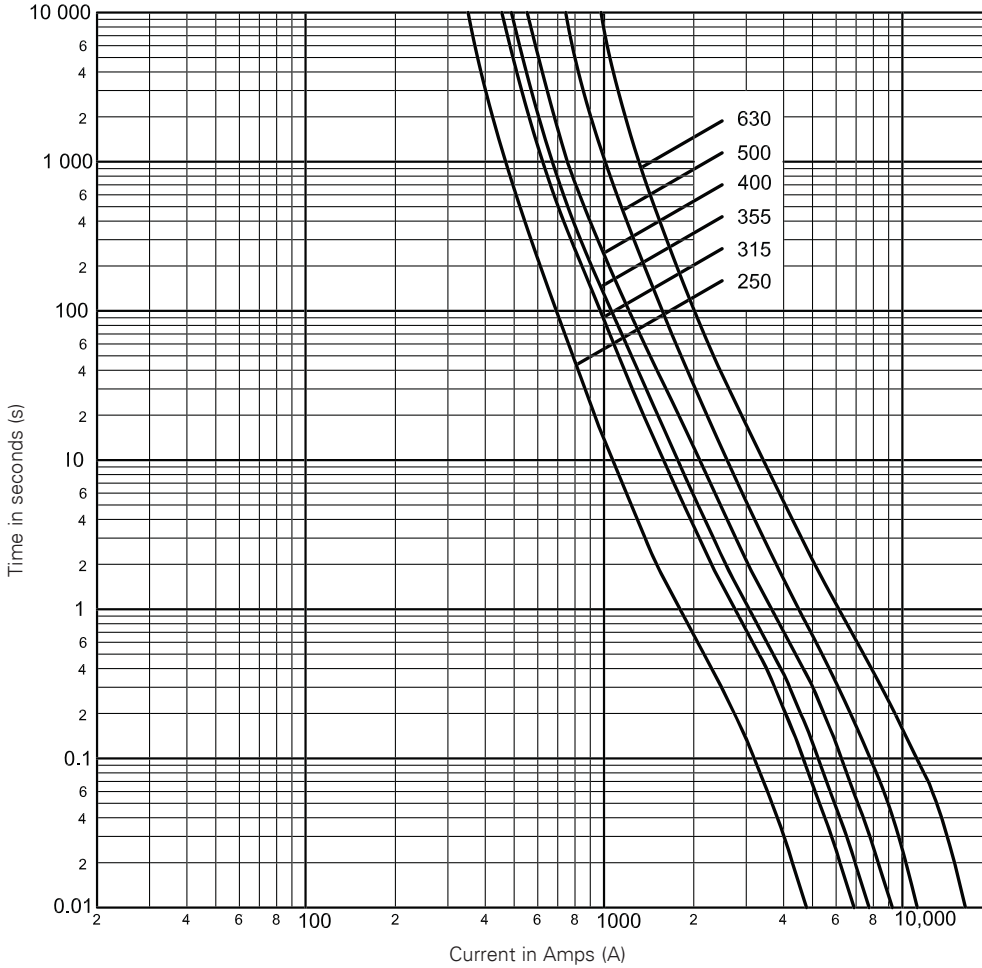

Technical data

Catalogue Numbers With Metal Gripping Lugs	Catalogue Numbers With Insulated Metal Gripping Lugs	Fuse Link Size	Current (Amps)	Voltage (V a.c.)	I ² t (Amps ² Seconds)		Watts Loss (W)	Net Weight Per Fuse (Kg)
					Minimum Pre-Arcing	*I ₁ 120 kA at 400 V a.c.		
250NHG03B-400	250NHG03BI-400	03	250	400	115,000	379,500	18	0.634
315NHG03B-400	315NHG03BI-400		315		280,000	924,000	19	
355NHG03B-400	355NHG03BI-400		355		350,000	1,155,000	22	
400NHG03B-400	400NHG03BI-400		400		504,000	1,663,000	24	
500NHG3B-400	500NHG3BI-400	3	500	400	686,000	2,605,000	30	1.043
630NHG3B-400	630NHG3BI-400		630		1,590,000	6,201,000	36	

* I₁ is the maximum breaking capacity test at Voltage according to IEC 60269-1 and 2 requirements

500 V a.c. - class gG/gL - 2 to 1250 amps - sizes 000 to 4

Description

A square bodied range of industrial fuse links for a wide variety of applications.

Catalogue Numbers structure

- (amp)NHG(size)B e.g. 100NHG01B.

Class of operation

- gL/gG.

Standards / approvals

- IEC 60269-1 and 2, VDE 0636, DIN 43620 and CE.

Technical data

- Sizes 000 to 4
- Voltage: 500 V a.c.
- Current: 2 to 1250 A
- Rated breaking capacity: 120 kA AC
- Operating frequency: 45-62Hz.

Optional microswitch

- BVL50 or 170H0236.

Compatible fuse holders

- Fuse bases 1 pole:
 - SD(size)-D DIN-Rail mounted
 - SD(size)-S: Screw mounting
- Fuse bases 3 pole
 - TD(size)-D, DIN-Rail mounted
- Fuse bases accessories: IP20, shroud and phase barrier kits
- Fuse rails - vertical: EBF series
- Fuse switch disconnectors vertical: EBV series
- Fuse switch disconnectors horizontal: EBH series

Environmental

- Recyclable
- RoHS compliant
- Lead and cadmium free.

Packaging

- Size 000 to 3: 3 in a pack / Size 4: 1 in a pack.

Features:

- Reliable dual indicator system (size 4 single indication only)
- Low temperature rise
- Globally compliant.



500 V a.c. - class gG/gL - 2 to 1250 amps - sizes 000 to 4

Catalogue Numbers - sizes 000 to 01

Size	Current (Amps)	Voltage (V a.c.)	gG/gL Dual indicator		Pack Quantity
			Voltage Conducting Metal Gripping Lugs	Insulated Metal Gripping Lugs	
000	2	500	2NHG000B	2NHG000BI	3
	4		4NHG000B	4NHG000BI	
	6		6NHG000B	6NHG000BI	
	10		10NHG000B	10NHG000BI	
	16		16NHG000B	16NHG000BI	
	20		20NHG000B	20NHG000BI	
	25		25NHG000B	25NHG000BI	
	32		32NHG000B	32NHG000BI	
	35		35NHG000B	35NHG000BI	
	40		40NHG000B	40NHG000BI	
	50		50NHG000B	50NHG000BI	
	63		63NHG000B	63NHG000BI	
80	80NHG000B	80NHG000BI			
100	100NHG000B	100NHG000BI			
00	50	500	50NHG00B	50NHG00BI*	3
	63		63NHG00B	63NHG00BI*	
	80		80NHG00B	80NHG00BI*	
	100		100NHG00B	100NHG00BI*	
	125		125NHG00B	125NHG00BI	
160	160NHG00B	160NHG00BI			
0	6	500	6NHGOB	-	3
	10		10NHGOB	-	
	16		16NHGOB	-	
	20		20NHGOB	-	
	25		25NHGOB	-	
	32		32NHGOB	-	
	35		35NHGOB	-	
	40		40NHGOB	-	
	50		50NHGOB	-	
	63		63NHGOB	-	
	80		80NHGOB	-	
	100		100NHGOB	-	
125	125NHGOB	-			
160	160NHGOB	-			
01	6	500	6NHG01B	6NHG01BI	3
	10		10NHG01B	10NHG01BI	
	16		16NHG01B	16NHG01BI	
	20		20NHG01B	20NHG01BI	
	25		25NHG01B	25NHG01BI	
	32		32NHG01B	32NHG01BI	
	35		35NHG01B	35NHG01BI	
	40		40NHG01B	40NHG01BI	
	50		50NHG01B	50NHG01BI	
	63		63NHG01B	63NHG01BI	
	80		80NHG01B	80NHG01BI	
	100		100NHG01B	100NHG01BI	
125	125NHG01B	125NHG01BI			
160	160NHG01B	160NHG01BI			



* Available upon request

Data sheet 10164

500 V a.c. - class gG/gL - 2 to 1250 amps - sizes 000 to 4

Catalogue Numbers - sizes 1 to 4					
Size	Current (Amps)	Voltage (V a.c.)	gG/gL Dual Indicator		Pack Quantity
			Voltage Conducting Metal Gripping Lugs	Insulated Metal Gripping Lugs	
1	50	500	50NHG1B	50NHG1BI	3
	63		63NHG1B	63NHG1BI	
	80		80NHG1B	80NHG1BI	
	100		100NHG1B	100NHG1BI	
	125		125NHG1B	125NHG1BI	
	160		160NHG1B	160NHG1BI	
	200		200NHG1B	200NHG1BI	
	224		224NHG1B	224NHG1BI	
	250		250NHG1B	250NHG1BI	
	315		440	315NHG1B	
355	355NHG1B	355NHG1BI			
02	35	500	35NHG02B	35NHG02BI	3
	40		40NHG02B	40NHG02BI	
	50		50NHG02B	50NHG02BI	
	63		63NHG02B	63NHG02BI	
	80		80NHG02B	80NHG02BI	
	100		100NHG02B	100NHG02BI	
	125		125NHG02B	125NHG02BI	
	160		160NHG02B	160NHG02BI	
	200		200NHG02B	200NHG02BI	
	224		224NHG02B	224NHG02BI	
250	250NHG02B	250NHG02BI			
2	250	500	250NHG2B	250NHG2BI	3
	300		300NHG2B	300NHG2BI	
	315		315NHG2B	315NHG2BI	
	355		355NHG2B	355NHG2BI	
	400		400NHG2B	400NHG2BI	
	425		425NHG2B	425NHG2BI	
	450		450NHG2B	450NHG2BI	
	500		440	500NHG2B	
03	250	500	250NHG03B	250NHG03BI	3
	315		315NHG03B	315NHG03BI	
	355		355NHG03B	355NHG03BI	
	400		400NHG03B	400NHG03BI	
3	315	500	315NHG3B	-	3
	355		355NHG3B	-	
	400		400NHG3B	-	
	425		425NHG3B	-	
	450		450NHG3B	-	
	500		500NHG3B	-	
	630		630NHG3B	-	
	800		440	800NHG3B	
4**	500	500	500NHG4G	-	1
	630		630NHG4G	-	
	800		800NHG4G	-	
	1000		1000NHG4G	-	
	1250		1250NHG4G	-	



500Vac

* Available upon request

** Size 4 NH is a single indication fuse with slotted end tags

500 V a.c. - class gG/gL - 2 to 100 amps - size 000

Time-current characteristics

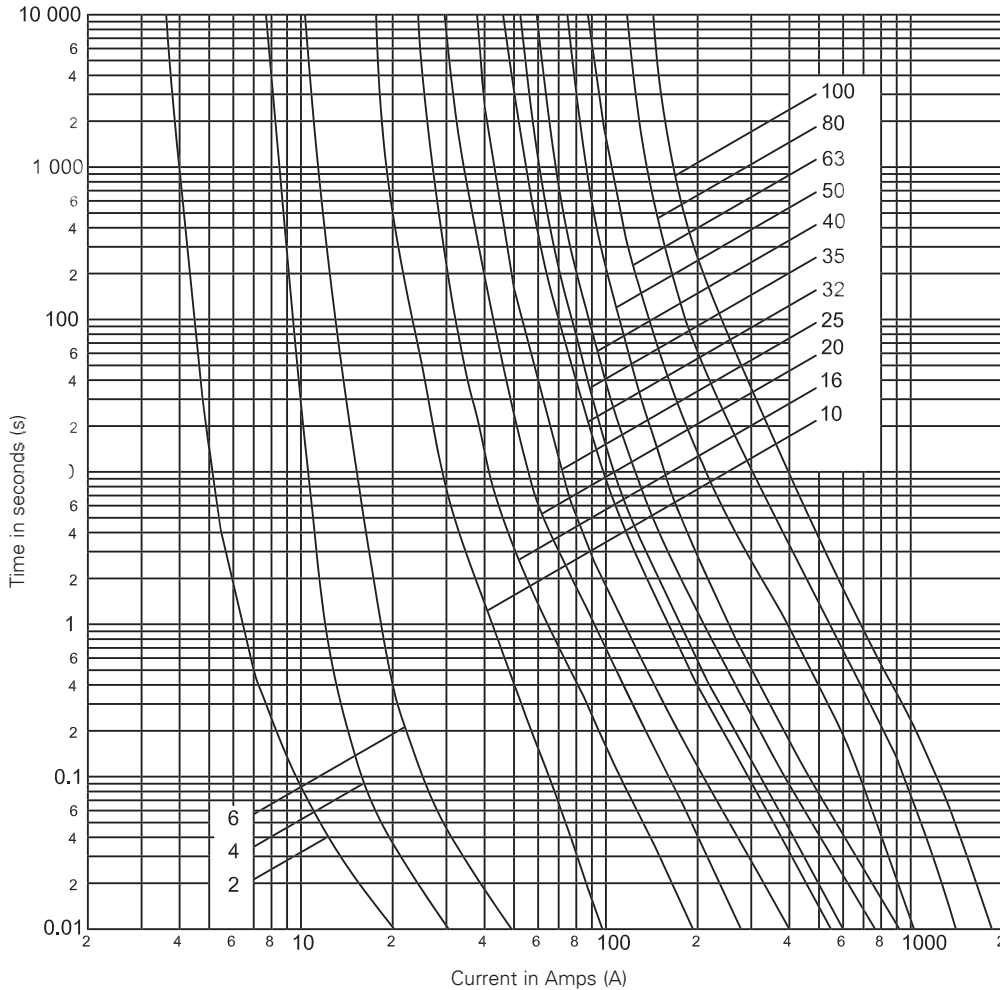

Technical data

Catalogue Numbers With Metal Gripping Lugs	Catalogue Numbers With Insulated Metal Gripping Lugs	Fuse Link Size	Current (Amps)	Voltage (V a.c.)	I ² t (Amps ² Seconds)		Watts Loss (W)	Net Weight Per Fuse (Kg)
					Minimum Pre-Arcing	*I ₁ 120 kA at 500 V a.c.		
2NHG000B	2NHG000BI	000	2	500	3.5	6	3.9	0.130
4NHG000B	4NHG000BI		4		6	12	1.8	
6NHG000B	6NHG000BI		6		14	21	2	
10NHG000B	10NHG000BI		10		58	290	1.5	
16NHG000B	16NHG000BI		16		234	1200	2.3	
20NHG000B	20NHG000BI		20		490	2500	2.2	
25NHG000B	25NHG000BI		25		920	4600	3.1	
32NHG000B	32NHG000BI		32		1800	9000	3.4	
35NHG000B	35NHG000BI		35		2400	11,800	3.7	
40NHG000B	40NHG000BI		40		3300	16,500	4	
50NHG000B	50NHG000BI		50		5900	29,500	4.9	
63NHG000B	63NHG000BI		63		6300	24,900	4.6	
80NHG000B	80NHG000BI		80		9800	38,900	6.3	
100NHG000B	100NHG000BI		100		18,100	72,300	7.4	

* I₁ is the maximum breaking capacity test at Voltage according to IEC 60269-1 and 2 requirements

Data sheet 10164

500 V a.c. - class gG/gL - 50 to 160 amps - size 00

Time-current characteristics

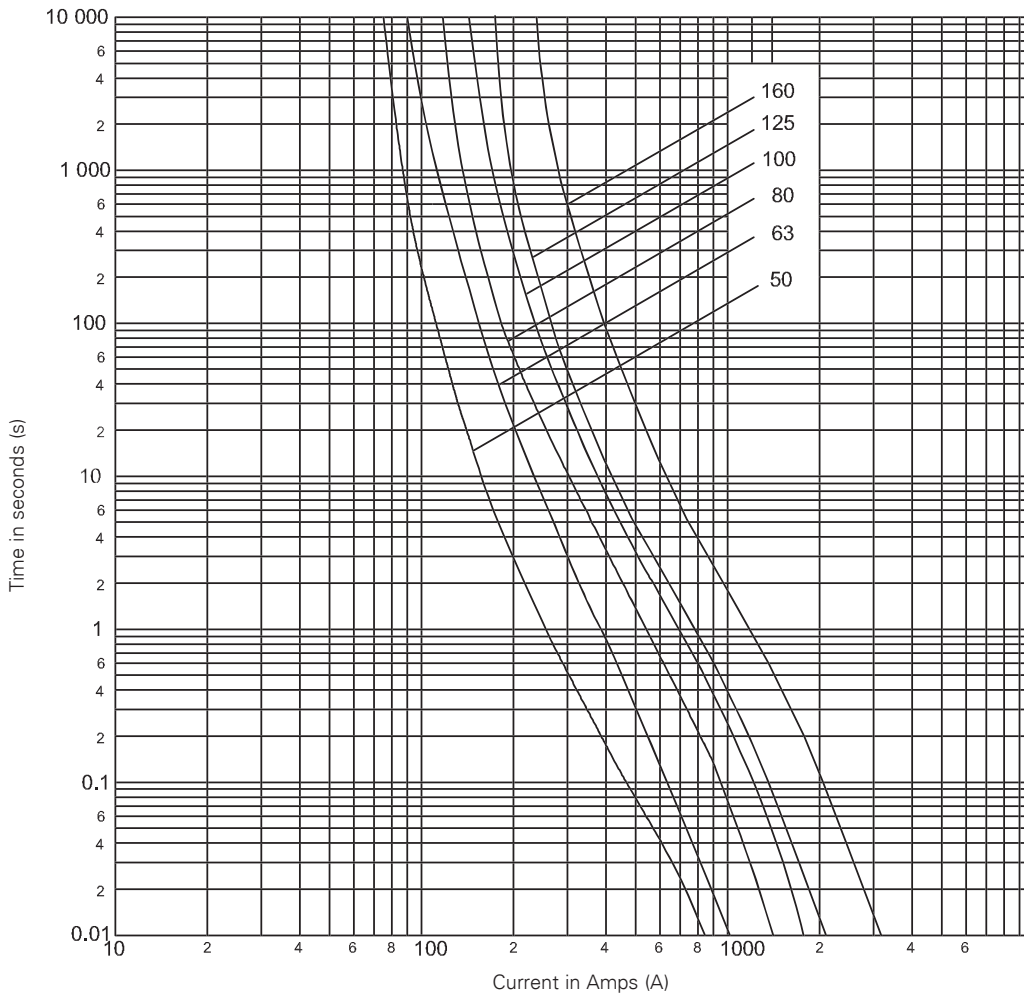

500Vac

Technical data

Catalogue Numbers With Metal Gripping Lugs	Catalogue Numbers With Insulated Metal Gripping Lugs	Fuse Link Size	Current (Amps)	Voltage (V a.c.)	I ² t (Amps ² Seconds)		Watts Loss (W)	Net Weight Per Fuse (Kg)
					Minimum Pre-Arcing	*I ₁ , 120 kA at 500 V a.c.		
50NHG00B	50NHG00BI	00	50	500	5800	21,500	5	0.190
63NHG00B	63NHG00BI		63		5800	25,000	5	
80NHG00B	80NHG00BI		80		11,000	35,000	7	
100NHG00B	100NHG00BI		100		19,000	60,000	7.5	
125NHG00B	125NHG00BI		125		25,000	125,000	10	
160NHG00B	160NHG00BI		160		64,000	310,000	10	

* I₁ is the maximum breaking capacity test at Voltage according to IEC 60269-1 and 2 requirements

500 V a.c. - class gG/gL - 6 to 160 amps - size 0

Time-current characteristics

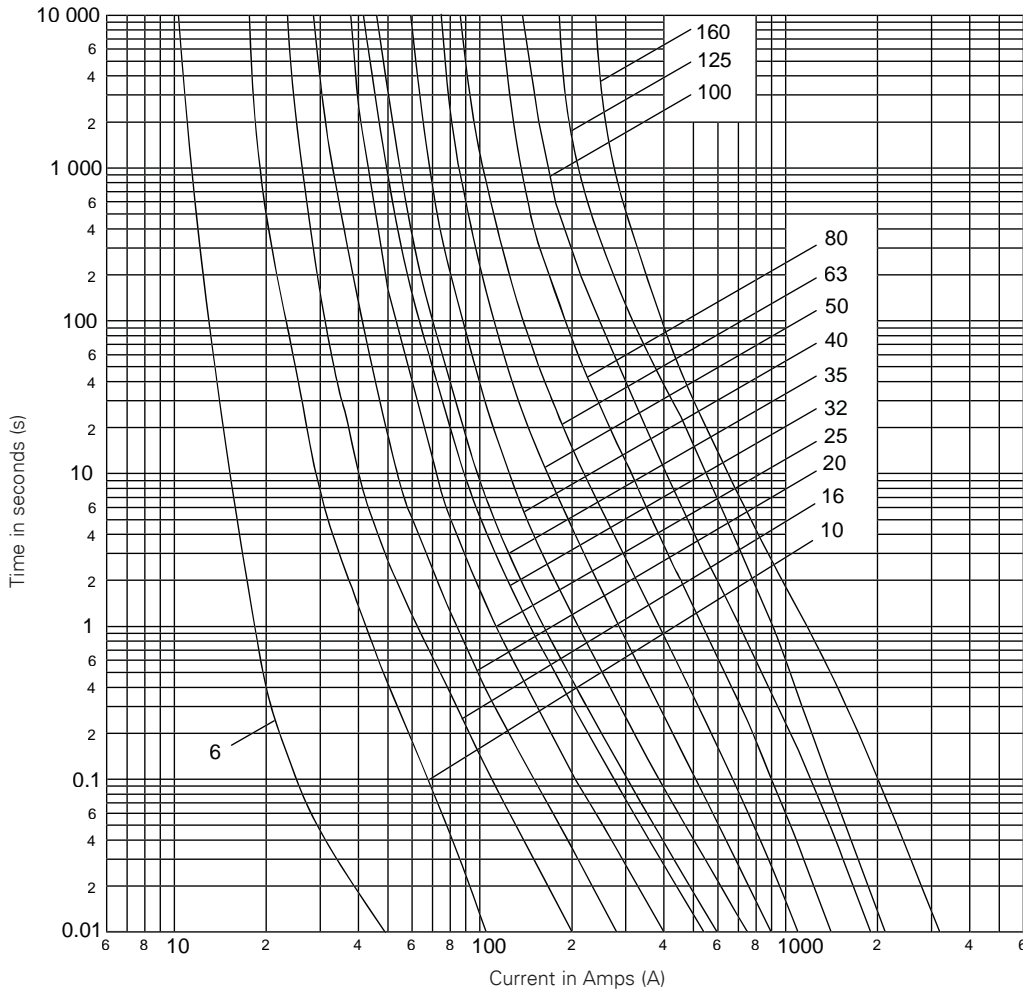

Technical data

Catalogue Numbers With Metal Gripping Lugs	Fuse Link Size	Current (Amps)	Voltage (V a.c.)	I^2t (Amps ² Seconds)		Watts Loss (W)	Net Weight Per Fuse (Kg)
				Minimum Pre-Arcing	* I_1 120 kA at 500 V a.c.		
6NHGOB	0	6	500	14	21	2	0.260
10NHGOB		10		58	290	2	
16NHGOB		16		240	1200	3	
20NHGOB		20		490	2500	3.5	
25NHGOB		25		1200	5600	3.2	
32NHGOB		32		1800	9000	4.8	
35NHGOB		35		2400	11,800	4.7	
40NHGOB		40		3300	16,500	5	
50NHGOB		50		5600	27,800	6.3	
63NHGOB		63		6600	26,100	5.6	
80NHGOB		80		9800	38,900	7.1	
100NHGOB		100		20,600	82,300	7.5	
125NHGOB		125		25,000	125,000	11.8	
160NHGOB		160		62,000	310,000	12.3	

* I_1 is the maximum breaking capacity test at Voltage according to IEC 60269-1 and 2 requirements

500 V a.c. - class gG/gL - 6 to 160 amps - size 01

Time-current characteristics

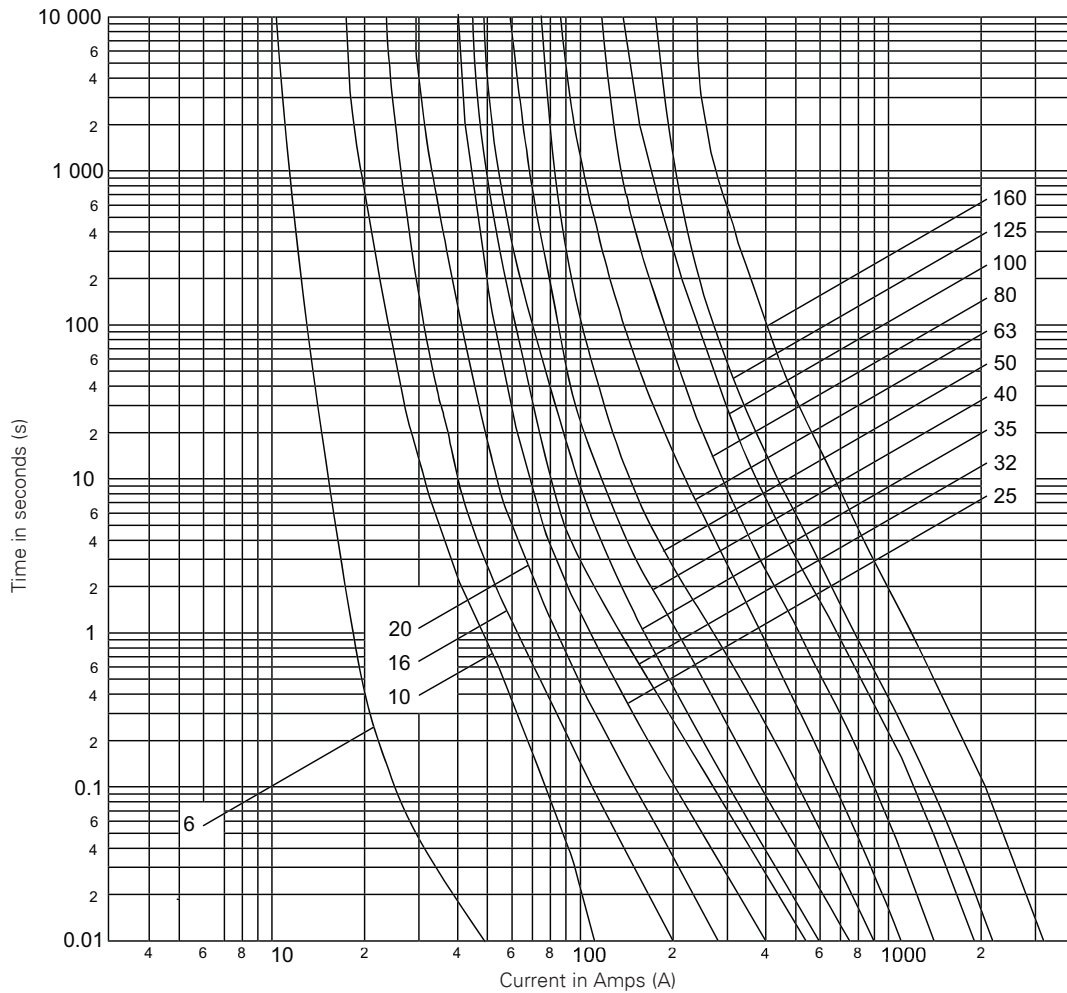

500Vac

Technical data

Catalogue Numbers With Metal Gripping Lugs	Catalogue Numbers With Insulated Metal Gripping Lugs	Fuse Link Size	Current (Amps)	Voltage (V a.c.)	I²t (Amps² Seconds)		Watts Loss (W)	Net Weight Per Fuse (Kg)
					Minimum Pre-Arcing	*I ₁ , 120 kA at 500 V a.c.		
6NHG01B	6NHG01BI	01	6	500	14	21	2	0.270
10NHG01B	10NHG01BI		10		58	290	2	
16NHG01B	16NHG01BI		16		240	1200	3	
20NHG01B	20NHG01BI		20		490	2500	3.4	
25NHG01B	25NHG01BI		25		1200	5600	5	
32NHG01B	32NHG01BI		32		1800	9000	4.8	
35NHG01B	35NHG01BI		35		2400	11,800	4.6	
40NHG01B	40NHG01BI		40		3300	16,500	5	
50NHG01B	50NHG01BI		50		5600	27,800	6.3	
63NHG01B	63NHG01BI		63		6600	26,100	5.6	
80NHG01B	80NHG01BI		80		9800	38,900	7.1	
100NHG01B	100NHG01BI		100		20,600	82,300	7.7	
125NHG01B	125NHG01BI		125		25,000	125,000	11.8	
160NHG01B	160NHG01BI		160		62,000	310,000	12.3	

* I₁ is the maximum breaking capacity test at Voltage according to IEC 60269-1 and 2 requirements

500 V a.c. - class gG/gL - 50 to 355 amps - size 1

Time-current characteristics

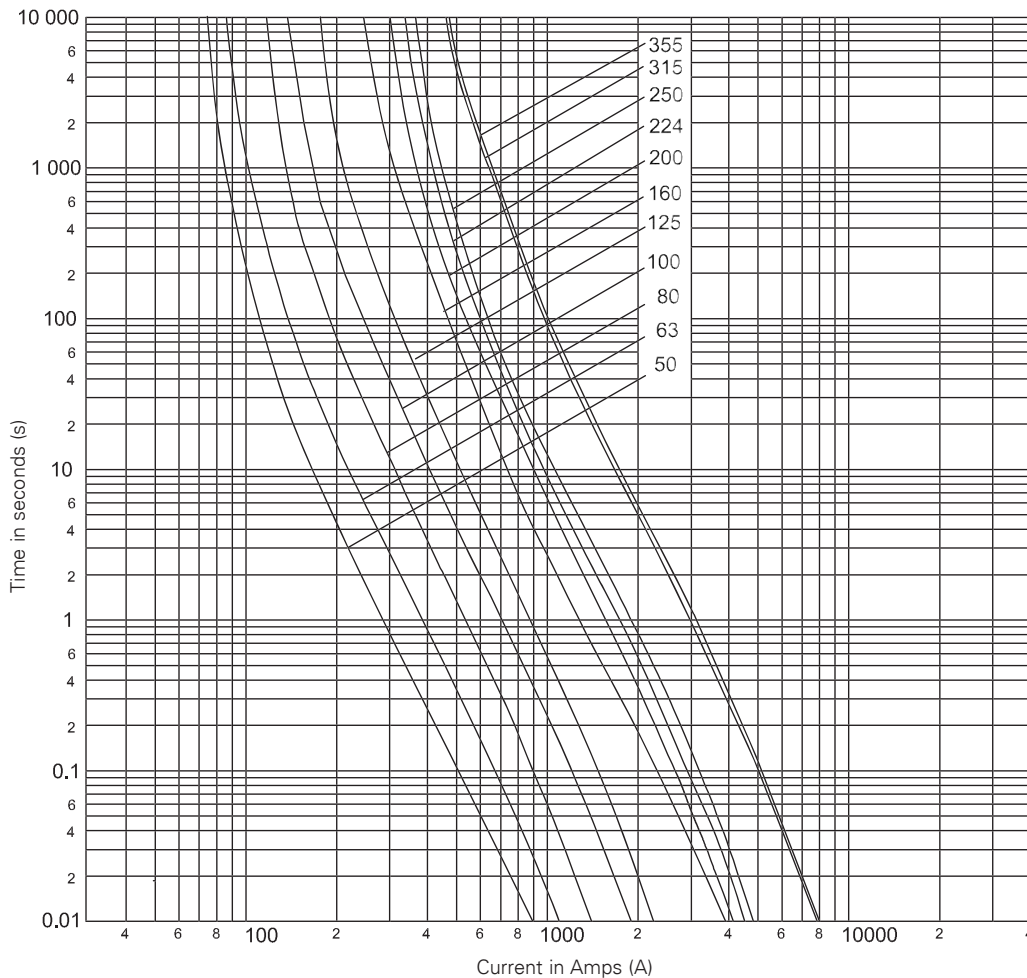

Technical data

Catalogue Numbers With Metal Gripping Lugs	Catalogue Numbers With Insulated Metal Gripping Lugs	Fuse Link Size	Current (Amps)	Voltage (V a.c.)	I ² t (Amps ² Seconds)		Watts Loss (W)	Net Weight Per Fuse (Kg)
					Minimum Pre-Arcing	*I ₁ , 120 kA at 500 V a.c.		
50NHG1B	50NHG1BI	1	50	500	6350	18,000	6.4	0.390
63NHG1B	63NHG1BI		63		6800	23,000	5.6	
80NHG1B	80NHG1BI		80		10,500	31,200	7.7	
100NHG1B	100NHG1BI		100		22,000	68,200	8.2	
125NHG1B	125NHG1BI		125		29,000	82,000	13	
160NHG1B	160NHG1BI		160		62,000	310,000	12.3	
200NHG1B	200NHG1BI		200		97,000	368,600	15	
224NHG1B	224NHG1BI		224		124,000	471,200	18	
250NHG1B	250NHG1BI		250		151,300	574,900	19	
315NHG1B	315NHG1BI		315	440	320,000	750,000	22	
355NHG1B	355NHG1BI		355		320,000	750,000	32	

* I₁ is the maximum breaking capacity test at Voltage according to IEC 60269-1 and 2 requirements

500 V a.c. - class gG/gL - 35 to 250 amps - size 02

Time-current characteristics

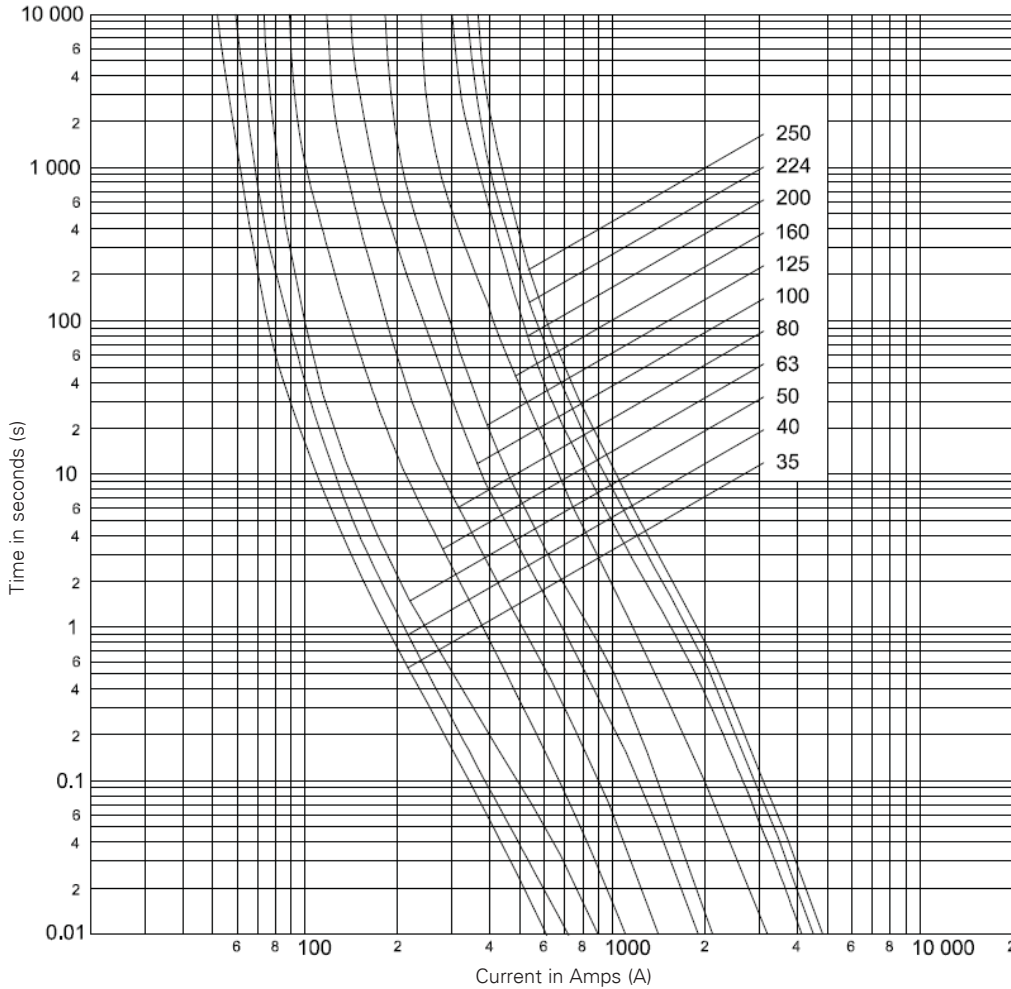

500Vac

Technical data

Catalogue Numbers With Metal Gripping Lugs	Catalogue Numbers With Insulated Metal Gripping Lugs	Fuse Link Size	Current (Amps)	Voltage (V a.c.)	I ² t (Amps ² Seconds)		Watts Loss (W)	Net Weight Per Fuse (Kg)
					Minimum Pre-Arcing	*I ₁ 120 kA at 500 V a.c.		
35NHG02B	35NHG02BI	02	35	500	2400	11,800	4.7	0.402
40NHG02B	40NHG02BI		40		3300	16,500	5	
50NHG02B	50NHG02BI		50		5600	27,800	6.4	
63NHG02B	63NHG02BI		63		6600	26,100	5.5	
80NHG02B	80NHG02BI		80		9800	38,900	7.3	
100NHG02B	100NHG02BI		100		20,600	82,300	7.5	
125NHG02B	125NHG02BI		125		25,000	100,000	12	
160NHG02B	160NHG02BI		160		62,000	248,000	12	
200NHG02B	200NHG02BI		200		96,900	367,900	15	
224NHG02B	224NHG02BI		224		124,000	471,200	18	
250NHG02B	250NHG02BI		250		151,300	574,900	19	

* I₁ is the maximum breaking capacity test at Voltage according to IEC 60269-1 and 2 requirements

500 V a.c. - class gG/gL - 250 to 500 amps - size 2

Time-current characteristics

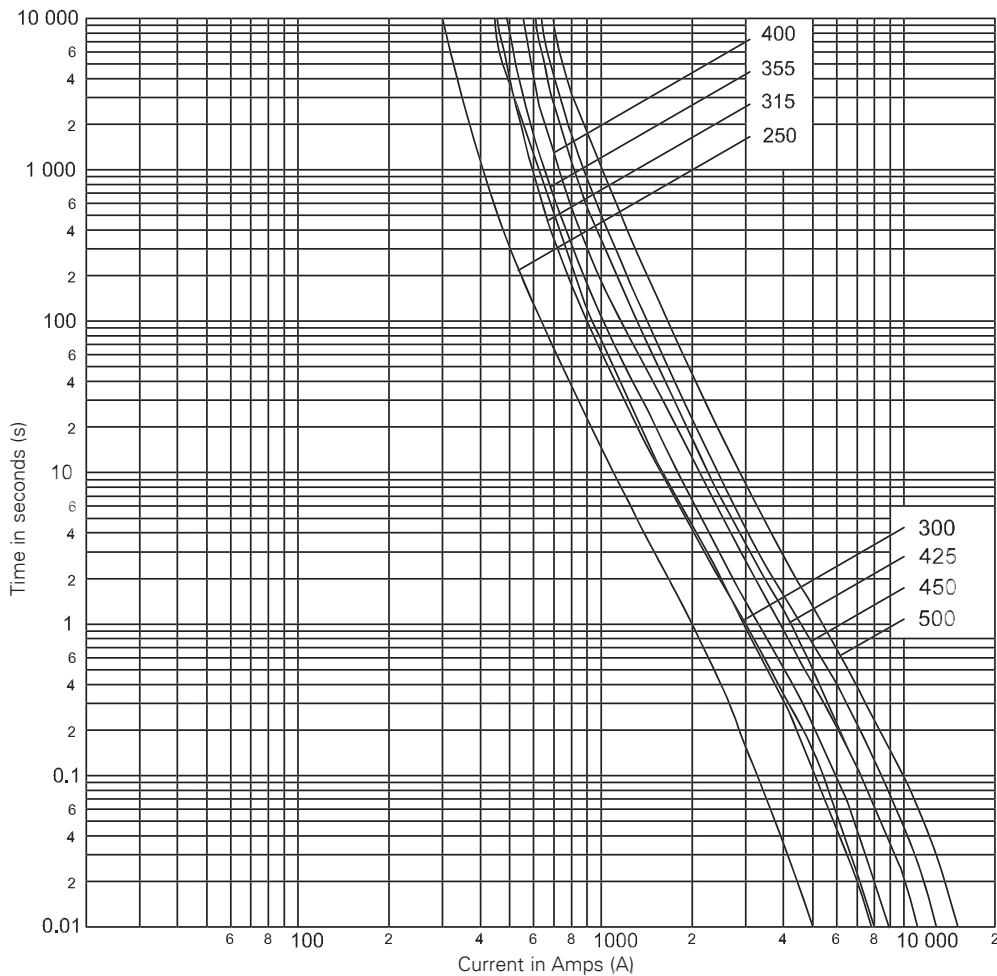

Technical data

Catalogue Numbers With Metal Gripping Lugs	Catalogue Numbers With Insulated Metal Gripping Lugs	Fuse Link Size	Current (Amps)	Voltage (V a.c.)	I ² t (Amps ² Seconds)		Watts Loss (W)	Net Weight Per Fuse (Kg)
					Minimum Pre-Arcing	*I _b , 120 kA at 500 V a.c.		
250NHG2B	250NHG2BI	2	250	500	170,000	437,000	23	0.630
300NHG2B	300NHG1BI		300		320,000	840,000	20	
315NHG2B	315NHG2BI		315		361,700	1,446,500	21	
355NHG2B	355NHG2BI		355		446,500	1,785,800	27	
400NHG2B	400NHG2BI		400		642,900	2,571,500	30	
425NHG2B	425NHG2BI		425		720,000	1,862,000	31	
450NHG2B	450NHG2BI		450		870,000	2,275,000	31	
500NHG2B	500NHG2BI	2	500	440	1,200,000	2,720,000	37	

* I_b is the maximum breaking capacity test at Voltage according to IEC 60269-1 and 2 requirements

500 V a.c. - class gG/gL - 250 to 400 amps - size 03

Time-current characteristics

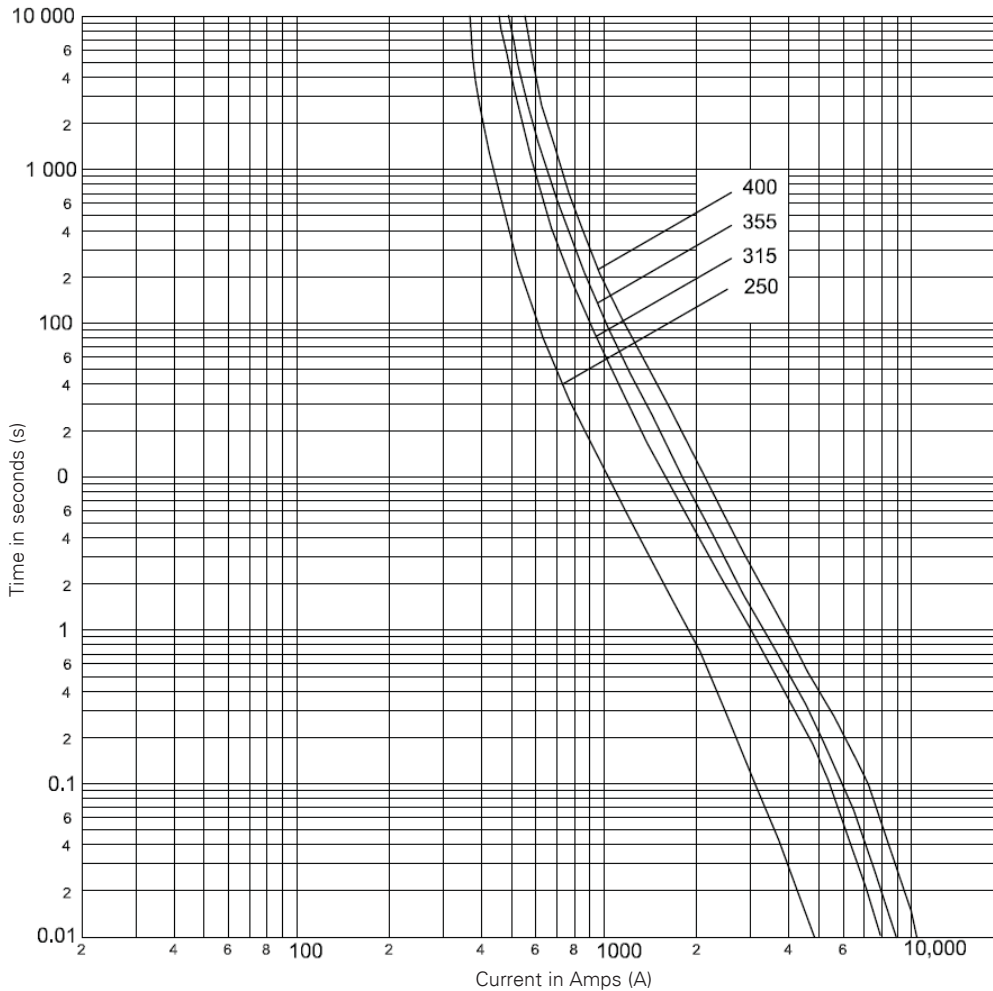

500Vac

Technical data

Catalogue Numbers With Metal Gripping Lugs	Catalogue Numbers With Insulated Metal Gripping Lugs	Fuse Link Size	Current (Amps)	Voltage (V a.c.)	I²t (Amps² Seconds)		Watts Loss (W)	Net Weight per Fuse (Kg)
					Minimum Pre-Arcing	*I ₁ 120 kA at 500 V a.c.		
250NHG03B	250NHG03BI	03	250	500	160,800	642,900	20	0.640
315NHG03B	315NHG03BI		315		361,700	1,446,500	21	
355NHG03B	355NHG03BI		355		446,500	1,785,800	27	
400NHG03B	400NHG03BI		400		642,900	2,571,500	30	

* I₁ is the maximum breaking capacity test at Voltage according to IEC 60269-1 and 2 requirements

500 V a.c. - class gG/gL - 315 to 800 amps - size 3

Time-current characteristics

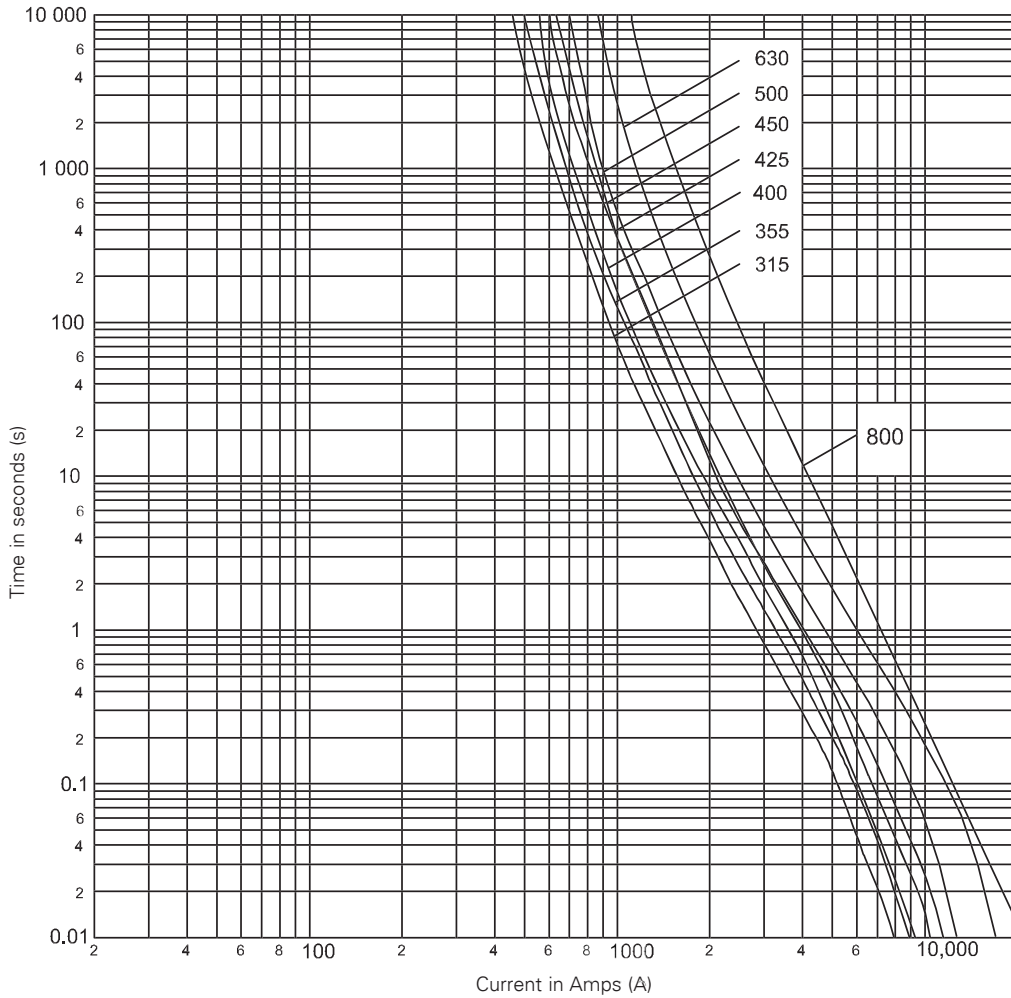

Technical data

Catalogue Numbers With Metal Gripping Lugs	Fuse Link Size	Current (Amps)	Voltage (V a.c.)	I ² t (Amps ² Seconds)		Watts Loss (W)	Net Weight Per Fuse (Kg)
				Minimum Pre-Arcing	*I ₁ 120 kA at 500 V a.c.		
315NHG3B	3	315	500	375,000	970,000	22	1.050
355NHG3B		355		400,000	1,110,000	25	
400NHG3B		400		642,900	2,571,500	30	
425NHG3B		425		570,000	1,934,000	30	
450NHG3B		450		670,000	2,260,000	33	
500NHG3B		500		886,000	3,898,400	37	
630NHG3B		630		1,590,000	6,996,000	47	
800NHG3B	3	800	440	2,420,000	5,420,000	59	1.050

* I₁ is the maximum breaking capacity test at Voltage according to IEC 60269-1 and 2 requirements

500 V a.c. - class gG/gL - 500 to 1250 amps - size 4*

Time-current characteristics

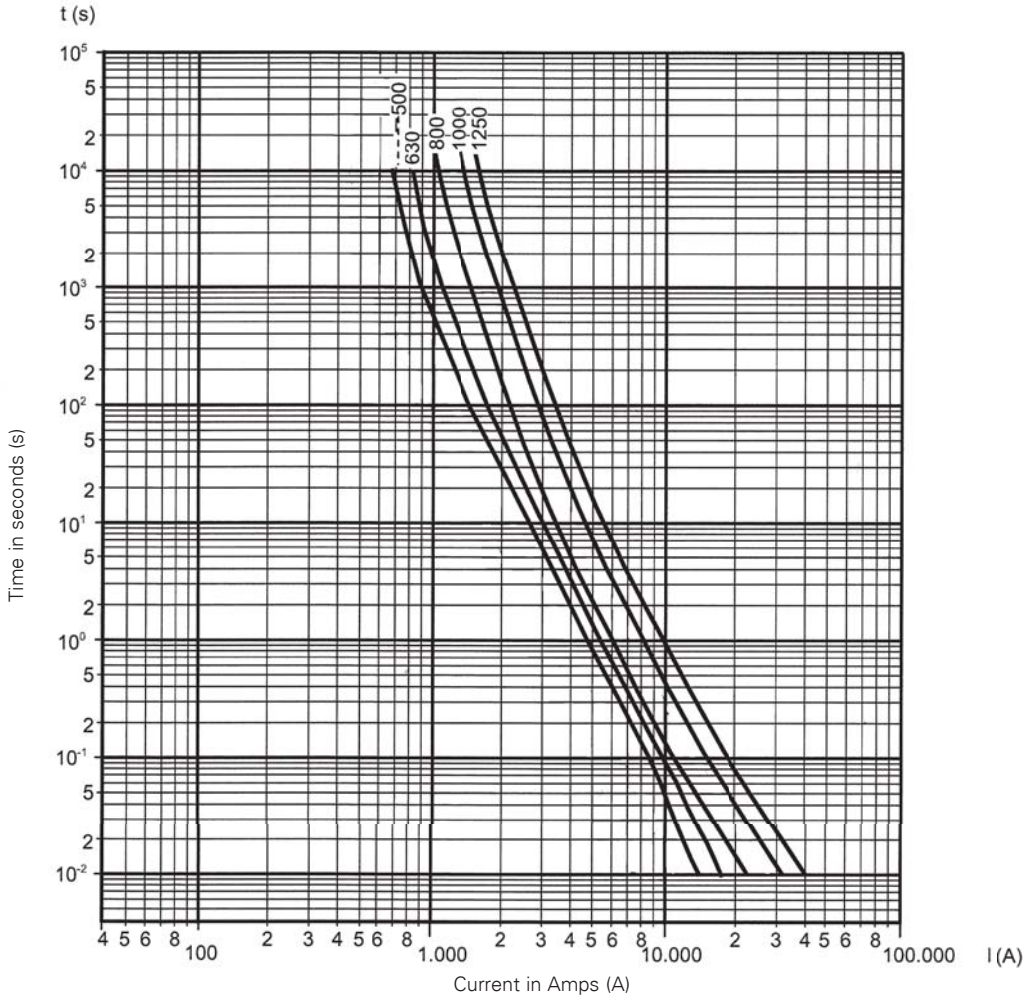

500Vac

Technical data

Catalogue Numbers With Metal Gripping Lugs	Fuse Link Size	Current (Amps)	Voltage (V a.c.)	I ² t (Amps ² Seconds)		Watts Loss (W)	Net Weight Per Fuse (Kg)
				Minimum Pre-Arcing	**I ₁ 120 kA at 500 V a.c.		
500NHG4G	4	500	500	800,000	3,850,000	37	2.200
630NHG4G		630		880,000	4,100,000	47	
800NHG4G		800		1,500,000	6,480,000	68	
1000NHG4G		1000		4,800,000	13,000,000	80	
1250NHG4G		1250		7,000,000	18,000,000	108	

* Size 4 NH is a single indication fuse with slotted end tags

** I₁ is the maximum breaking capacity test at Voltage according to IEC 60269-1 and 2 requirements

690 V a.c. - class gG/gL - 2 to 800 amps - sizes 000 to 4

Description

A square bodied range of industrial fuse links for a wide variety of applications.

Catalogue Numbers structure

- (amp)NHG(size)B-690 e.g. 2NHG000B-690.

Class of operation

- gL/gG.

Standards / approvals

- IEC 60269-1 and 2, DIN 43620 Part 1 and 3.

Technical data

- Sizes 000 to 4
- Voltage: 690 V a.c.
- Current: 2 to 800 A
- Rated breaking capacity: 120 kA
- Operating frequency: 45-62Hz.

Optional microswitch

- BVL50 or 170H0236.

Compatible fuse holders

- Fuse bases 1 pole:
 - SD(size)-D DIN-Rail mounted
 - SD(size)-S: Screw mounting
- Fuse bases 3 pole
 - TD(size)-D, DIN-Rail mounted
- Fuse bases accessories: IP20, shroud and phase barrier kits
- Fuse rails - vertical: EBF series
- Fuse switch disconnectors vertical: EBV series
- Fuse switch disconnectors horizontal: EBH series

Environmental

- Recyclable
- RoHS compliant
- Lead and cadmium free for sizes 000 to 4 (2 to 1250A).

Packaging

- Sizes 000 to 3: 3 per carton
- Size 4: 1 per carton

Features:

- Reliable dual indicator system (size 4 single indication only)
- Low temperature rise
- Globally compliant
- UL on limited ratings.



690 V a.c. - class gG/gL - 2 to 800 amps - sizes 000 to 4

Catalogue Numbers- sizes 000 to 4				
Size	Current (Amps)	Voltage (V a.c.)	gG/gL Dual Indicator	
			Voltage Conducting Metal Gripping Lugs	Pack Quantity
000	2	690	2NHG000B-690	3
	4		4NHG000B-690	
	6		6NHG000B-690	
	10		10NHG000B-690	
	16		16NHG000B-690	
	20		20NHG000B-690	
	25		25NHG000B-690	
	32		32NHG000B-690	
	35		35NHG000B-690	
	40		40NHG000B-690	
	50		50NHG000B-690	
	63		63NHG000B-690	
	00		50	
63		63NHG00B-690		
80		80NHG00B-690		
100		100NHG00B-690		
125		125NHG00B-690		
1	160	660	160NHG00B-660	3
	50	690	50NHG1B-690	
	63		63NHG1B-690	
	80		80NHG1B-690	
	100		100NHG1B-690	
	125		125NHG1B-690	
	160		160NHG1B-690	
	200		200NHG1B-690	
	224		224NHG1B-690	
	250		250NHG1B-690	
2	200		690	200NHG2B-690
	224	224NHG2B-690		
	250	250NHG2B-690		
	315	315NHG2B-690		
	3	690		250NHG3B-690
315	315NHG3B-690			
355	355NHG3B-690			
400	400NHG3B-690			
425	425NHG3B-690			
4*	500	500NHG3B-690	1	
	630	630NHG4B-690		
	800	800NHG4B-690		

*Size 4 is a fuse link with single indication fuse link with slotted end tags

Please consult us should you wish to order 500 Volts size 4
 buletechnical@eaton.com or 00 44 (0) 1509 882 699

Data sheet 720109



690Vac gG

690 V a.c. - class gG/gL - 2 to 63 amps - size 000

Time-current characteristics

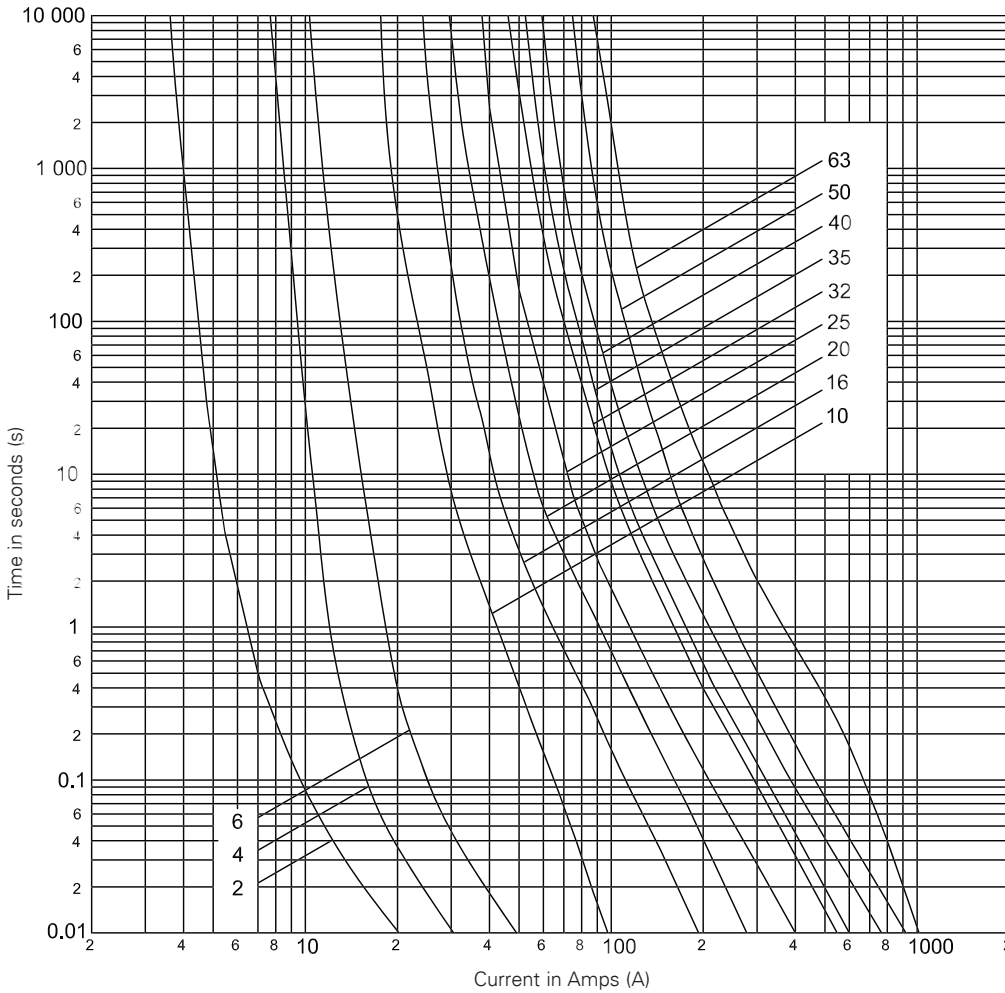

Technical data

Catalogue Numbers With Metal Gripping Lugs	Fuse Link Size	Current (Amps)	Voltage (V a.c.)	I ² t (Amps ² Seconds)		Watts Loss (W)	Net Weight Per Fuse (Kg)
				Minimum Pre-Arcing	*I ₁ 120 kA at 690 V a.c.		
2NHG000B-690	000	2	690	3.5	8	4	0.118
4NHG000B-690		4		6	16	2	
6NHG000B-690		6		14	25	2	
10NHG000B-690		10		60	400	1.5	
16NHG000B-690		16		240	1200	2.5	
20NHG000B-690		20		500	2500	2.5	
25NHG000B-690		25		920	4400	3.5	
32NHG000B-690		32		1800	9600	3.5	
35NHG000B-690		35		2800	15,000	4	
40NHG000B-690		40		3300	15,000	4	
50NHG000B-690		50		6100	26,500	5.5	
63NHG000B-690		63		6500	30,500	5.5	

* I₁ is the maximum breaking capacity test at Voltage according to IEC 60269-1 and 2 requirements

690 V a.c. - class gG/gL - 50 to 160 amps - size 00

Time-current characteristics

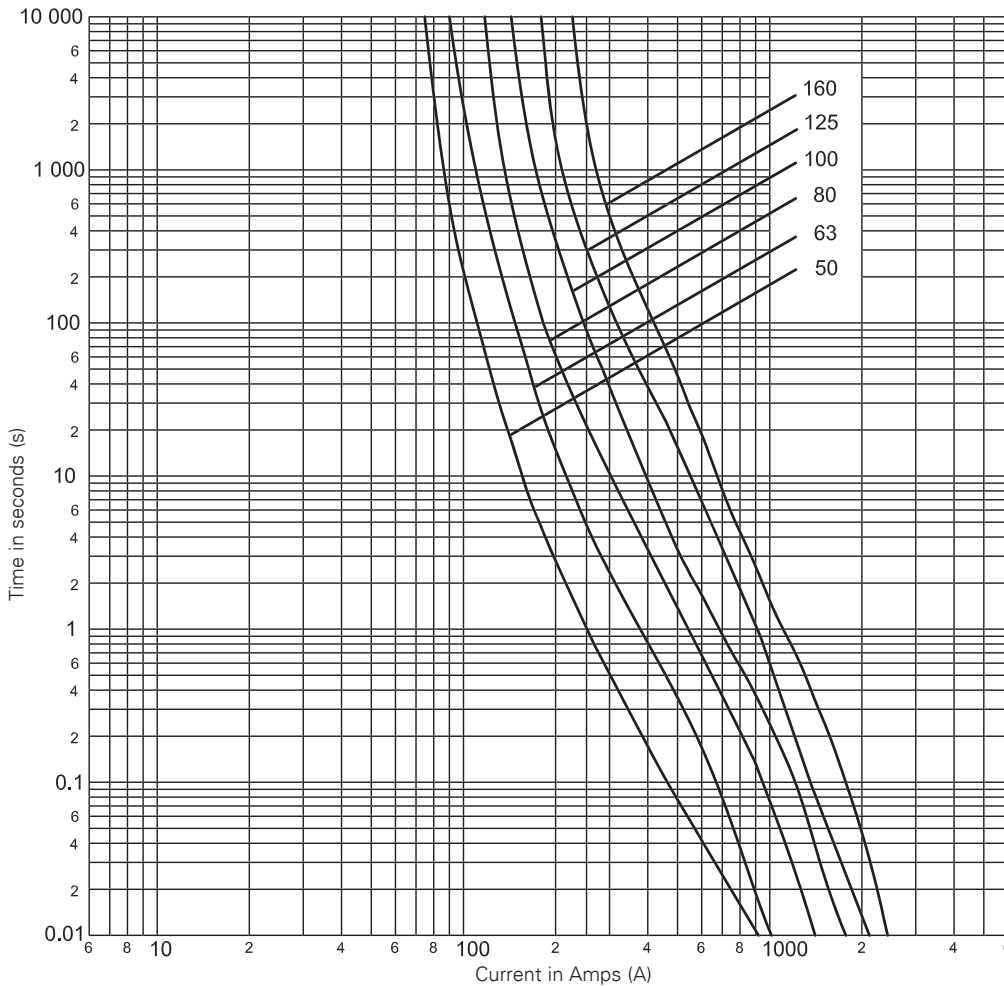

690Vac gG

Technical data

Catalogue Numbers With Metal Gripping Lugs	Fuse Link Size	Current (Amps)	Voltage (V a.c.)	I ² t (Amps ² Seconds)		Watts Loss (W)	Net Weight Per Fuse (Kg)
				Minimum Pre-Arcing	*I ₁ 120 kA at 690 V a.c.		
50NHG00B-690	00	50	690	5800	35,000	5	0.182
63NHG00B-690		63		5800	43,000	5	
80NHG00B-690		80		11,000	54,500	7	
100NHG00B-690		100		19,000	92,000	7.5	
125NHG00B-690		125		27,500	105,000	9.5	
160NHG00B-660	00	160	660	40,500	135,000	13	0.182

* I₁ is the maximum breaking capacity test at Voltage according to IEC 60269-1 and 2 requirements

690 V a.c. - class gG/gL - 50 to 250 amps - size 1

Time-current characteristics

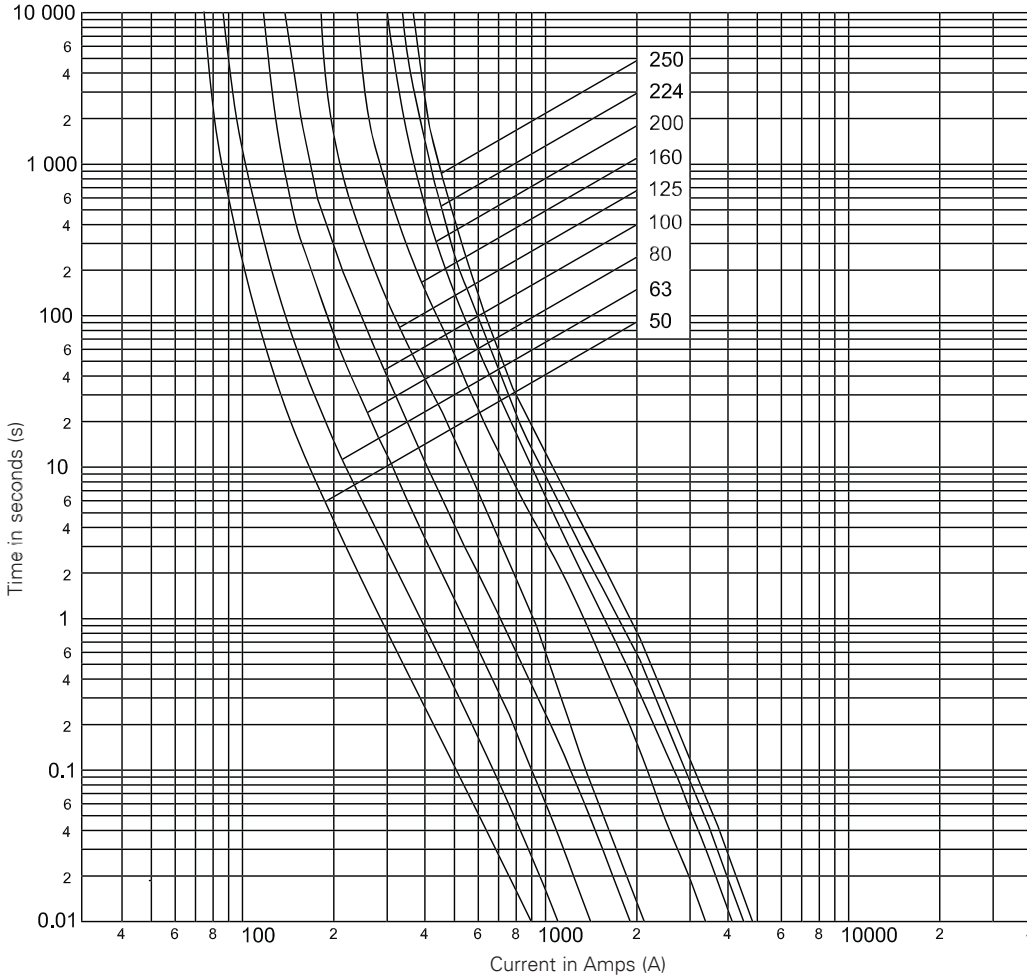

Technical data

Catalogue Numbers With Metal Gripping Lugs	Fuse Link Size	Current (Amps)	Voltage (V a.c.)	I ² t (Amps ² Seconds)		Watts Loss (W)	Net Weight Per Fuse (Kg)
				Minimum Pre-Arcing	*I _b 120 kA at 690 V a.c.		
50NHG1B-690	1	50	690	6350	26,500	6.4	0.380
63NHG1B-690		63		6800	36,000	5.6	
80NHG1B-690		80		10,500	47,500	7.7	
100NHG1B-690		100		22,000	105,000	8.2	
125NHG1B-690		125		29,000	120,000	13	
160NHG1B-690		160		71,000	240,000	13	
200NHG1B-690		200		105,000	350,000	17	
224NHG1B-690		224		120,000	430,000	19	
250NHG1B-690		250		150,000	520,000	22	

* I_b is the maximum breaking capacity test at Voltage according to IEC 60269-1 and 2 requirements

690 V a.c. - class gG/gL - 200 to 315 amps - size 2

Time-current characteristics

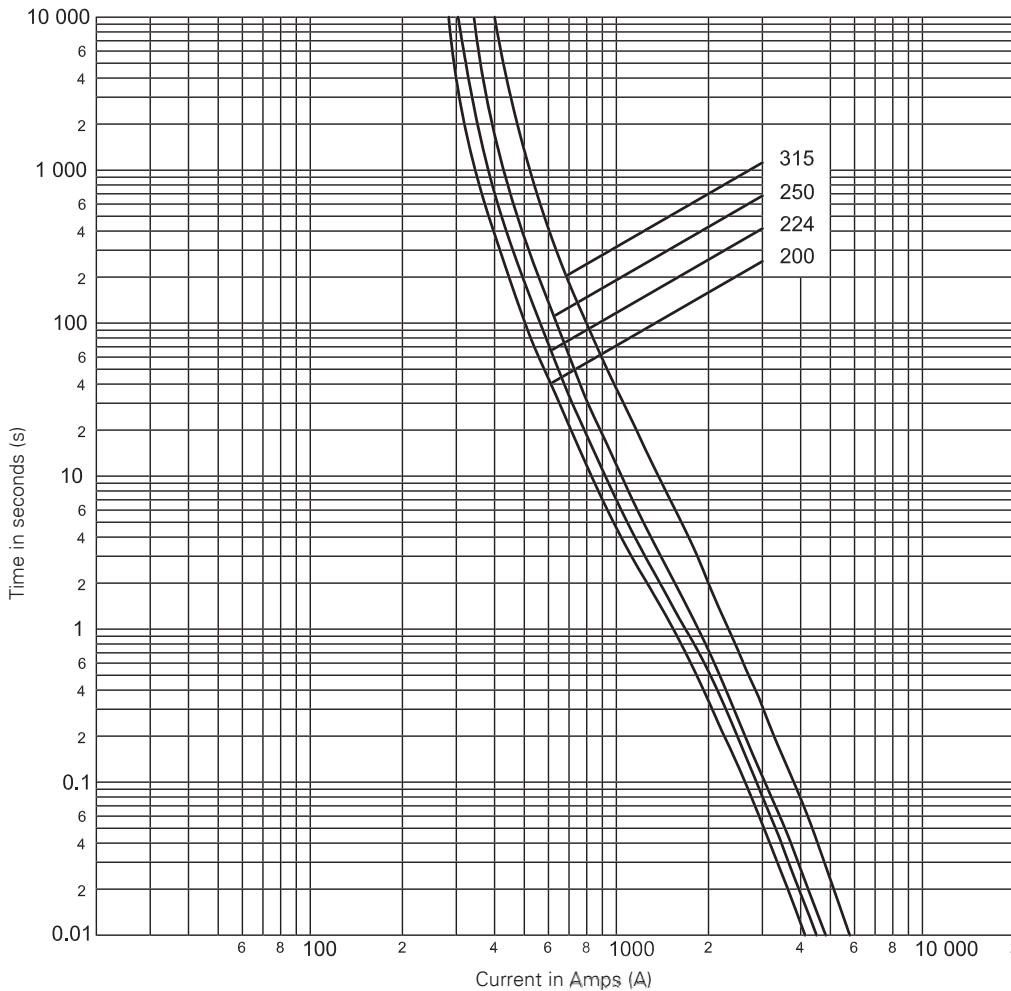

690Vac gG

Technical data

Catalogue Numbers With Metal Gripping Lugs	Fuse Link Size	Current (Amps)	Voltage (V a.c.)	I ² t (Amps ² Seconds)		Watts Loss (W)	Net Weight Per Fuse (Kg)
				Minimum Pre-Arcing	*I _b 120 kA at 690 V a.c.		
200NHG2B-690	2	200	690	99,000	385,000	18	0.620
224NHG2B-690		224		130,000	485,000	20	
250NHG2B-690		250		170,000	625,000	23	
315NHG2B-690		315		295,000	760,000	32	

* I_b is the maximum breaking capacity test at Voltage according to IEC 60269-1 and 2 requirements

690 V a.c. - class gG/gL - 250 to 500 amps - size 3

Time-current characteristics

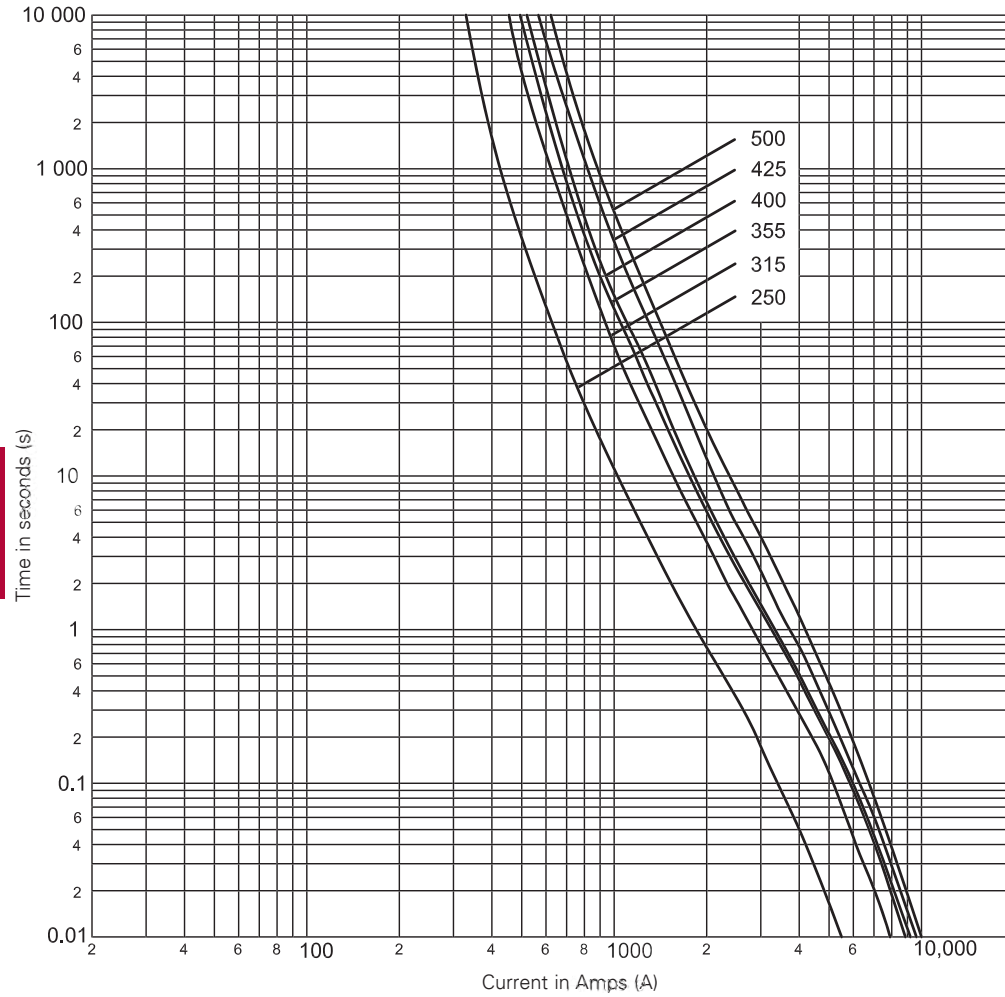

Technical data

Catalogue Numbers With Metal Gripping Lugs	Fuse Link Size	Current (Amps)	Voltage (V a.c.)	I ² t (Amps ² Seconds)		Watts Loss (W)	Net Weight Per Fuse (Kg)
				Minimum Pre-Arcing	*I ₁ 120 kA at 690 V a.c.		
250NHG3B-690	3	250	690	160,000	715,000	21	1.050
315NHG3B-690		315		375,000	1,400,000	22	
355NHG3B-690		355		400,000	1,650,000	25	
400NHG3B-690		400		475,000	1,600,000	37	
425NHG3B-690		425		630,000	1,700,000	35	
500NHG3B-690		500		856,000	2,480,000	43	

* I₁ is the maximum breaking capacity test at Voltage according to IEC 60269-1 and 2 requirements

690 V a.c. - class gG/gL - 630 and 800 amps - size 4*

Time-current characteristics

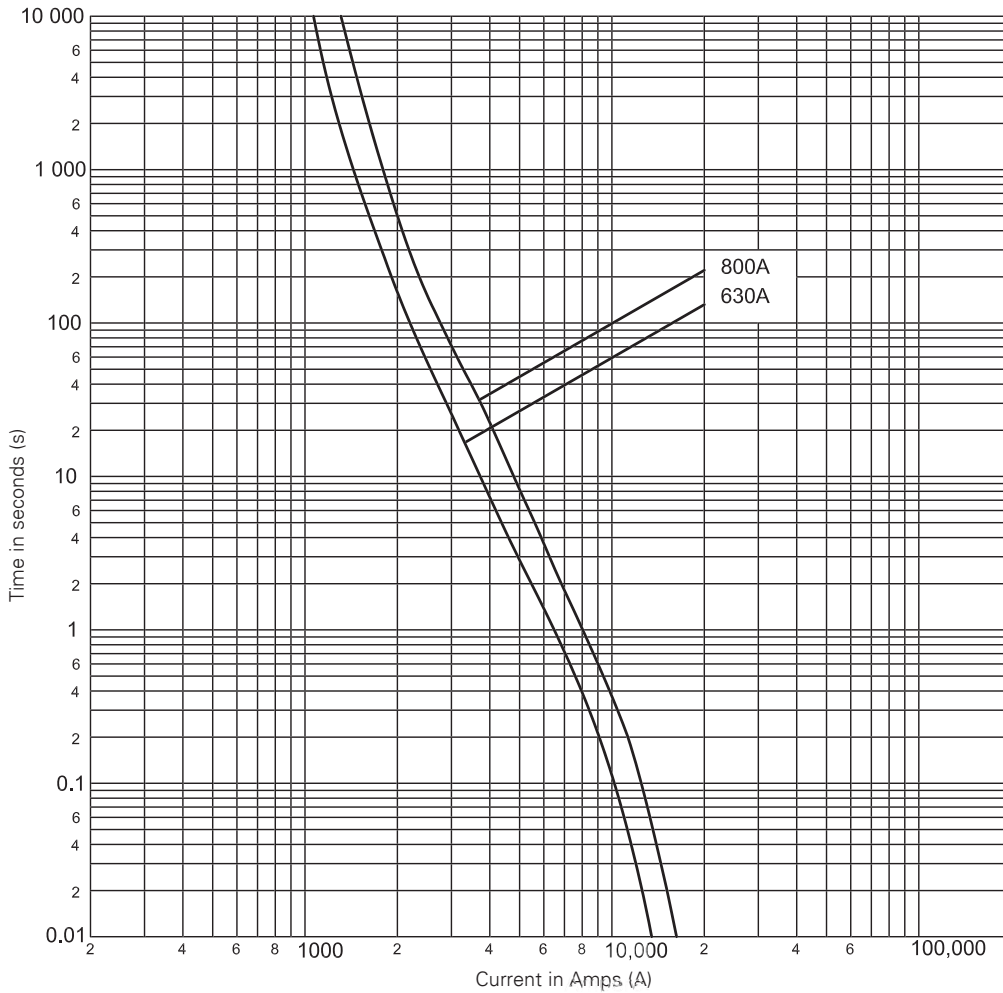

690Vac gG

Technical data

Catalogue Numbers With Metal Gripping Lugs	Fuse Link Size	Current (Amps)	Voltage (V a.c.)	I ² t (Amps ² Seconds)		Watts Loss (W)	Net Weight Per Fuse (Kg)
				Minimum Pre-Arcing	*I ₁ 120 kA at 690 V a.c.		
630NHG4B-690	4	630	690	1,730,000	6,550,000	44	2.500
800NHG4B-690		800		3,330,000	11,000,000	61	

*Single indication fuse link with slotted end tags

** I₁ is the maximum breaking capacity test at Voltage according to IEC 60269-1 and 2 requirements

Please consult us should you wish to order 500 Volts size 4 buletechnical@eaton.com or 00 44 (0) 1509 882 699

500 and 690 V a.c. - class aM - 6 to 500 amps - sizes 000 to 3

Description

A range of class aM square bodied industrial fuse links for a wide variety of motor protection applications.

Catalogue Numbers structure

- 500 Volts: (amp)NHM(size)B
- 690 Volts: (amp)NHM(size)B-690.

Class of operation

- aM.

Standards / approvals

- IEC 60269-1 and 2, DIN 43620 Part 1 and 3.

Technical data

- Sizes 000 to 3
- Voltage: 500 and 690 V a.c.
- Current: 6 to 500 A
- Rated breaking capacity: 120 kA
- Operating frequency: 45-62Hz.

Optional microswitch

- BVL50 or 170H0236.

Compatible fuse holders

- Fuse bases 1 pole:
 - SD(size)-D DIN-Rail mounted
 - SD(size)-S: Screw mounting
- Fuse bases 3 pole
 - TD(size)-D, DIN-Rail mounted
- Fuse bases accessories: IP20, shroud and phase barrier kits
- Fuse rails - vertical: EBF series
- Fuse switch disconnectors vertical: EBV series
- Fuse switch disconnectors horizontal: EBH series

Environmental

- Recyclable
- RoHS compliant
- Lead and cadmium free.

Packaging

- All fuse links are packed in threes.

Features:

- Reliable dual indicator system (except size 2, 315 and 355 A which are single indication)
- Low watts loss
- Metal gripping lugs.



500 and 690 V a.c. - class aM - 6 to 500 amps - sizes 000 to 3

Catalogue Numbers- sizes 000 to 3				
Size	Current (Amps)	500 V a.c. class aM	690 V a.c. class aM	Pack Quantity
		Voltage Conducting Metal Gripping Lugs	Voltage Conducting Metal Gripping Lugs	
000	6	6NHM000B	6NHM000B-690	3
	10	10NHM000B	10NHM000B-690	
	16	16NHM000B	16NHM000B-690	
	20	20NHM000B	20NHM000B-690	
	25	25NHM000B	25NHM000B-690	
	32	32NHM000B	32NHM000B-690	
	35	35NHM000B	35NHM000B-690	
	40	40NHM000B	40NHM000B-690	
	50	50NHM000B	50NHM000B-690	
00	63	63NHM00B	63NHM00B-690	3
	80	80NHM00B	80NHM00B-690	
	100	100NHM00B	100NHM00B-690	
1	50	50NHM1B	50NHM1B-690	3
	63	63NHM1B	63NHM1B-690	
	80	80NHM1B	80NHM1B-690	
	100	100NHM1B	100NHM1B-690	
	125	125NHM1B	125NHM1B-690	
	160	160NHM1B	160NHM1B-690	
2	125	125NHM2B	125NHM2B-690	3
	160	160NHM2B	160NHM2B-690	
	200	200NHM2B	200NHM2B-690	
	224	224NHM2B	224NHM2B-690	
	250	250NHM2B	250NHM2B-690	
	315*	315NHM2B*	315NHM2B-690*	
	355*	355NHM2B*	355NHM2B-690*	
3	315	315NHM3B	315NHM3B-690	3
	355	355NHM3B	355NHM3B-690	
	400	400NHM3B	400NHM3B-690	
	500	500NHM3B	500NHM3B-690	

* Single indication



500 and 690 V a.c. - class aM - 6 to 50 amps - size 000

Time-current characteristics

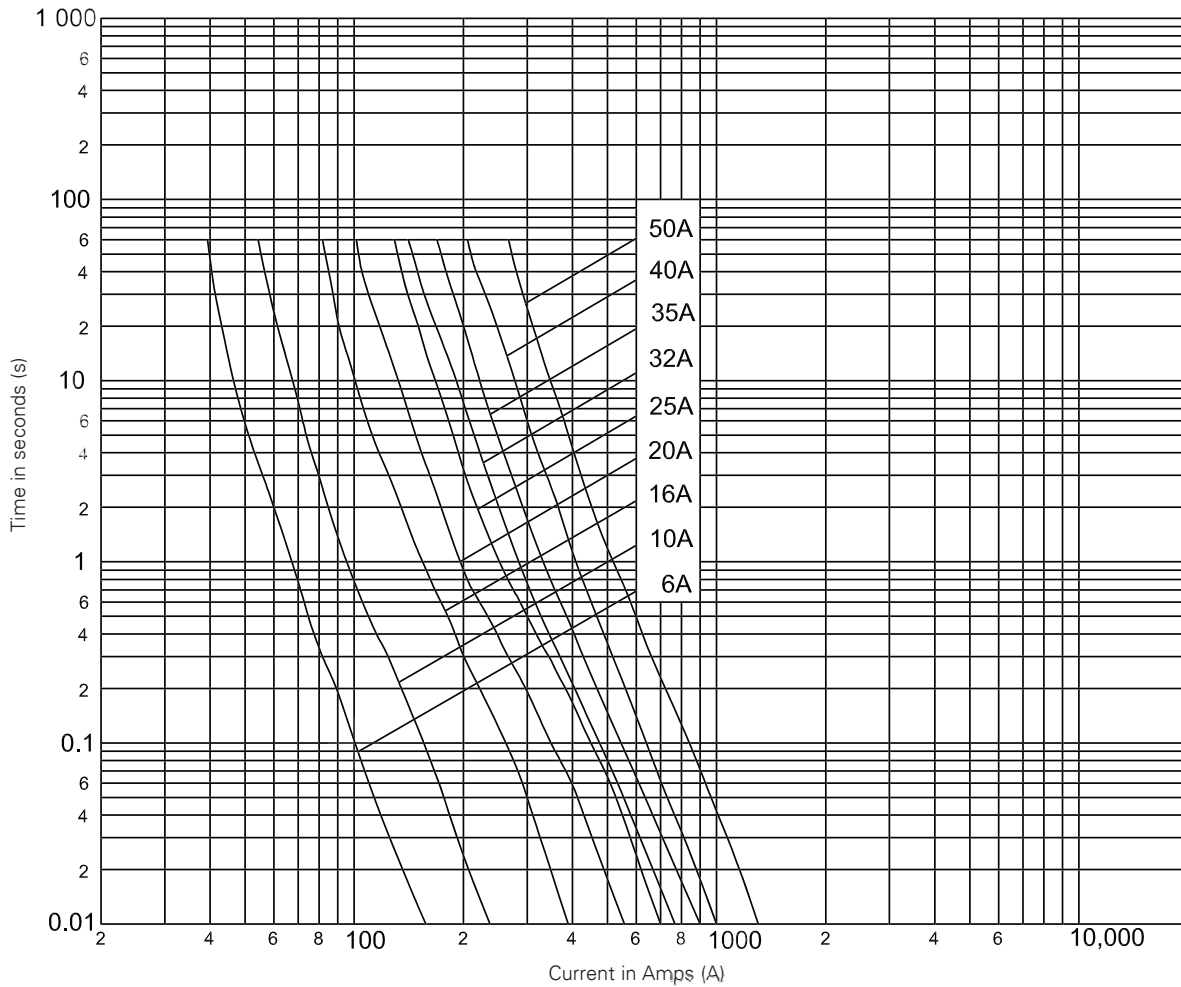

Technical data

500 V a.c.	690 V a.c.	Fuse Link Size	Current (Amps)	I ² t (Amps ² Seconds)		Watts Loss (W)	Net Weight Per Fuse (Kg)
Catalogue Numbers With Metal Gripping Lugs	Catalogue Numbers With Metal Gripping Lugs			Minimum Pre-Arcing	*I ₁ 120 kA at 690 V a.c.		
6NHM000B	6NM000B-690	000	6	48	650	0.3	0.118
10NHM000B	10NHM000B-690		10	200	1800	0.5	
16NHM000B	16NHM000B-690		16	500	4400	0.8	
20NHM000B	20NHM000B-690		20	1450	7250	0.9	
25NHM000B	25NHM000B-690		25	3500	13,500	1.1	
32NHM000B	32NHM000B-690		32	2200	7500	2.1	
35NHM000B	35NHM000B-690		35	3000	12,000	2.1	
40NHM000B	40NHM000B-690		40	4700	14,500	2.3	
50NHM000B	50NHM000B-690		50	11,000	27,000	2.7	

* I₁ is the maximum breaking capacity test at Voltage according to IEC 60269-1 and 2 requirements

500 and 690 V a.c. - class aM - 63 to 100 amps - size 00

Time-current characteristics

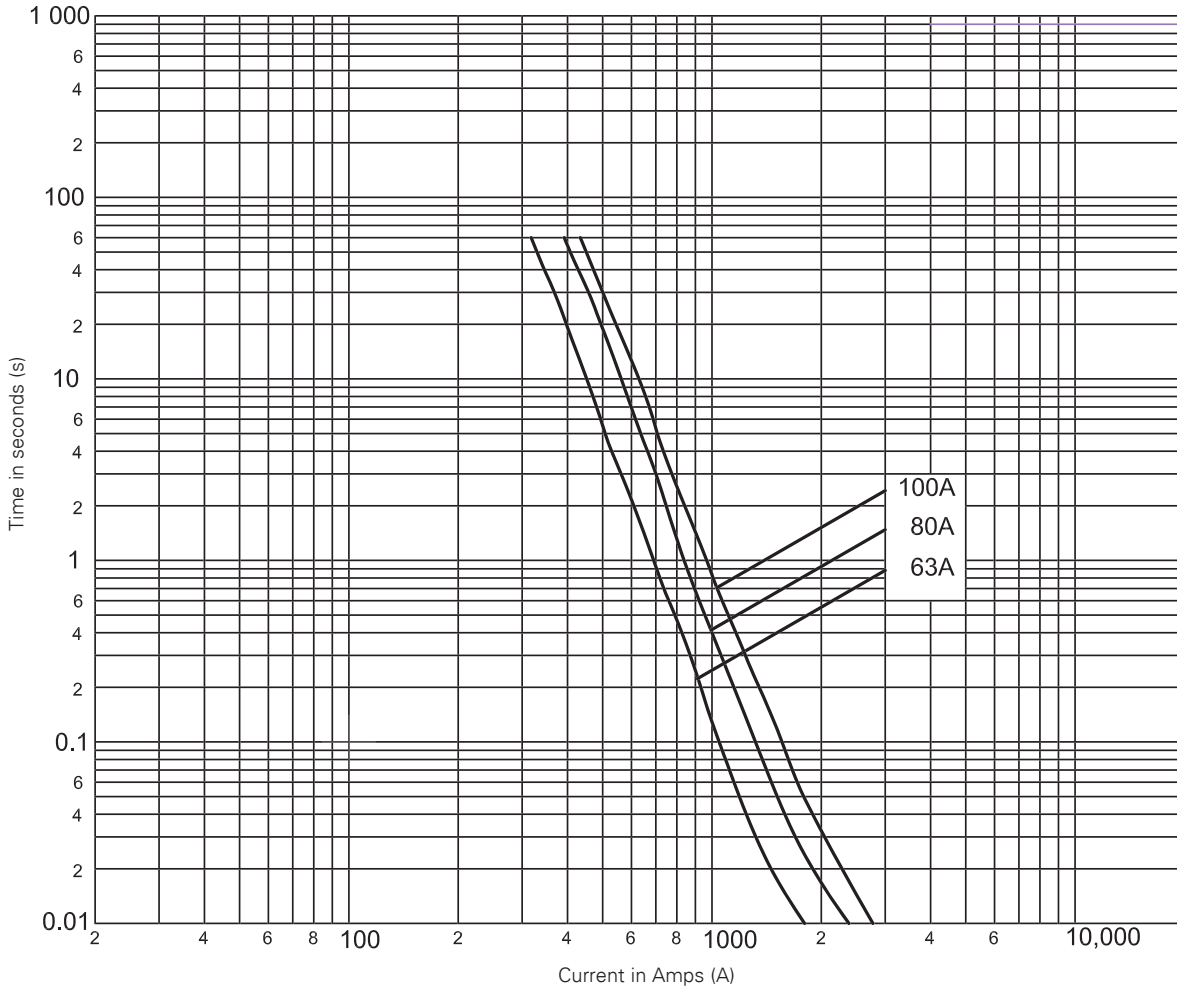

Technical data

500 V a.c.		690 V a.c.		I ² t (Amps ² Seconds)		Watts Loss (W)	Net Weight Per Fuse (Kg)
Catalogue Numbers With Metal Gripping Lugs	Catalogue Numbers With Metal Gripping Lugs	Fuse Link Size	Current (Amps)	Minimum Pre-Arcing	*I ₁ 120 kA at 690 V a.c.		
63NHM00B	63NHM00B-690	00	63	16,000	52,000	3.1	0.186
80NHM00B	80NHM00B-690		80	24,000	69,500	4.3	
100NHM00B	100NHM00B-690		100	35,000	110,000	5.5	

* I₁ is the maximum breaking capacity test at Voltage according to IEC 60269-1 and 2 requirements

500 and 690 V a.c. - class aM - 50 to 160 amps - size 1

Time-current characteristics

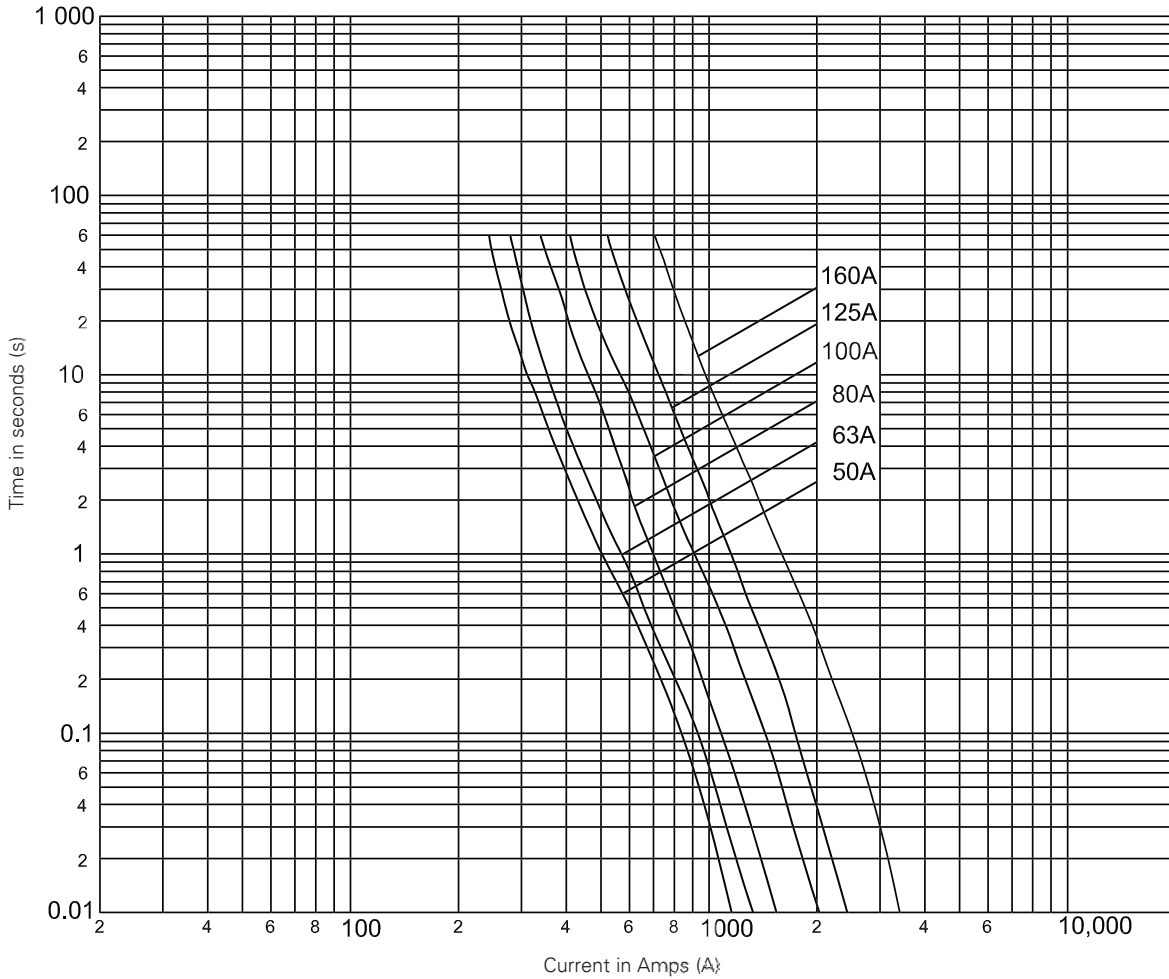

Technical data

500 V a.c.	690 V a.c.	Fuse Link Size	Current (Amps)	I ² t (Amps ² Seconds)		Watts Loss (W)	Net Weight Per Fuse (Kg)
Catalogue Numbers With Metal Gripping Lugs	Catalogue Numbers With Metal Gripping Lugs			Minimum Pre-Arcing	*I ₁ 120 kA at 690 V a.c.		
50NHM1B	50NHM1B-690	1	50	10,000	39,500	3	0.380
63NHM1B	63NHM1B-690		63	12,500	49,500	4.4	
80NHM1B	80NHM1B-690		80	19,500	77,500	5.6	
100NHM1B	100NHM1B-690		100	33,000	105,000	6.7	
125NHM1B	125NHM1B-690		125	49,500	170,000	8.8	
160NHM1B	160NHM1B-690		160	110,000	315,000	10.6	

* I₁ is the maximum breaking capacity test at Voltage according to IEC 60269-1 and 2 requirements

500 and 690 V a.c. - class aM - 125 to 355 amps - size 2

Time-current characteristics

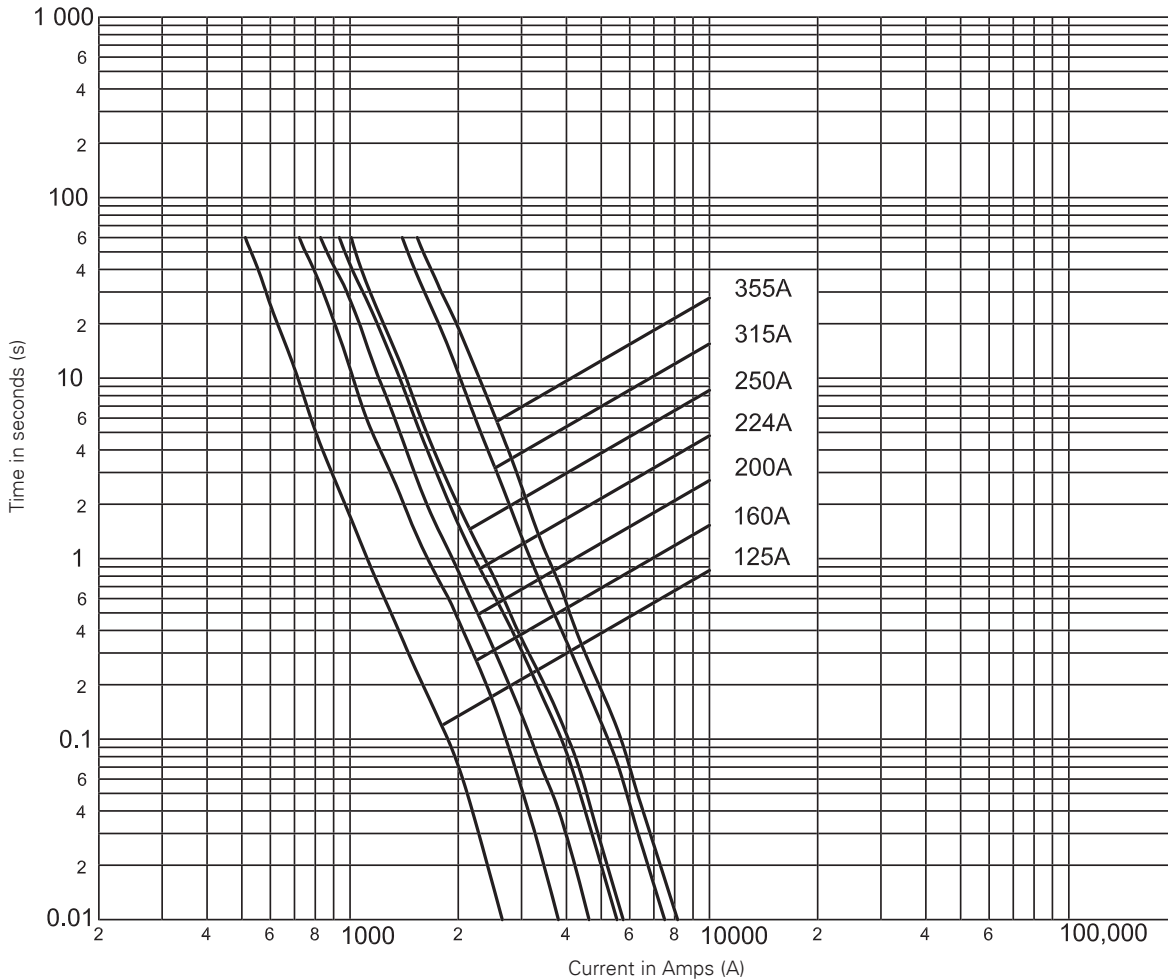

Technical data

500 V a.c.		690 V a.c.		I ² t (Amps ² Seconds)		Watts Loss (W)	Net Weight Per Fuse (Kg)
Catalogue Numbers With Metal Gripping Lugs	Catalogue Numbers With Metal Gripping Lugs	Fuse Link Size	Current (Amps)	Minimum Pre-Arcing	**I ₁ 120 kA at 690 V a.c.		
125NHM2B	125NHM2B-690	2	125	56,500	215,000	9.7	0.615
160NHM2B	160NHM2B-690		160	120,000	510,000	11	
200NHM2B	200NHM2B-690		200	175,000	730,000	14	
224NHM2B	224NHM2B-690		224	255,000	1,050,000	15	
250NHM2B	250NHM2B-690		250	300,000	1,280,000	17	
315NHM2B*	315NHM2B-690*		315	510,000	1,150,000	23	
355NHM2B*	355NHM2B-690*		355	570,000	1,300,000	28	

* Single indication

** I₁ is the maximum breaking capacity test at Voltage according to IEC 60269-1 and 2 requirements

500 and 690 V a.c. - class aM - 315 to 500 amps - size 3

Time-current characteristics

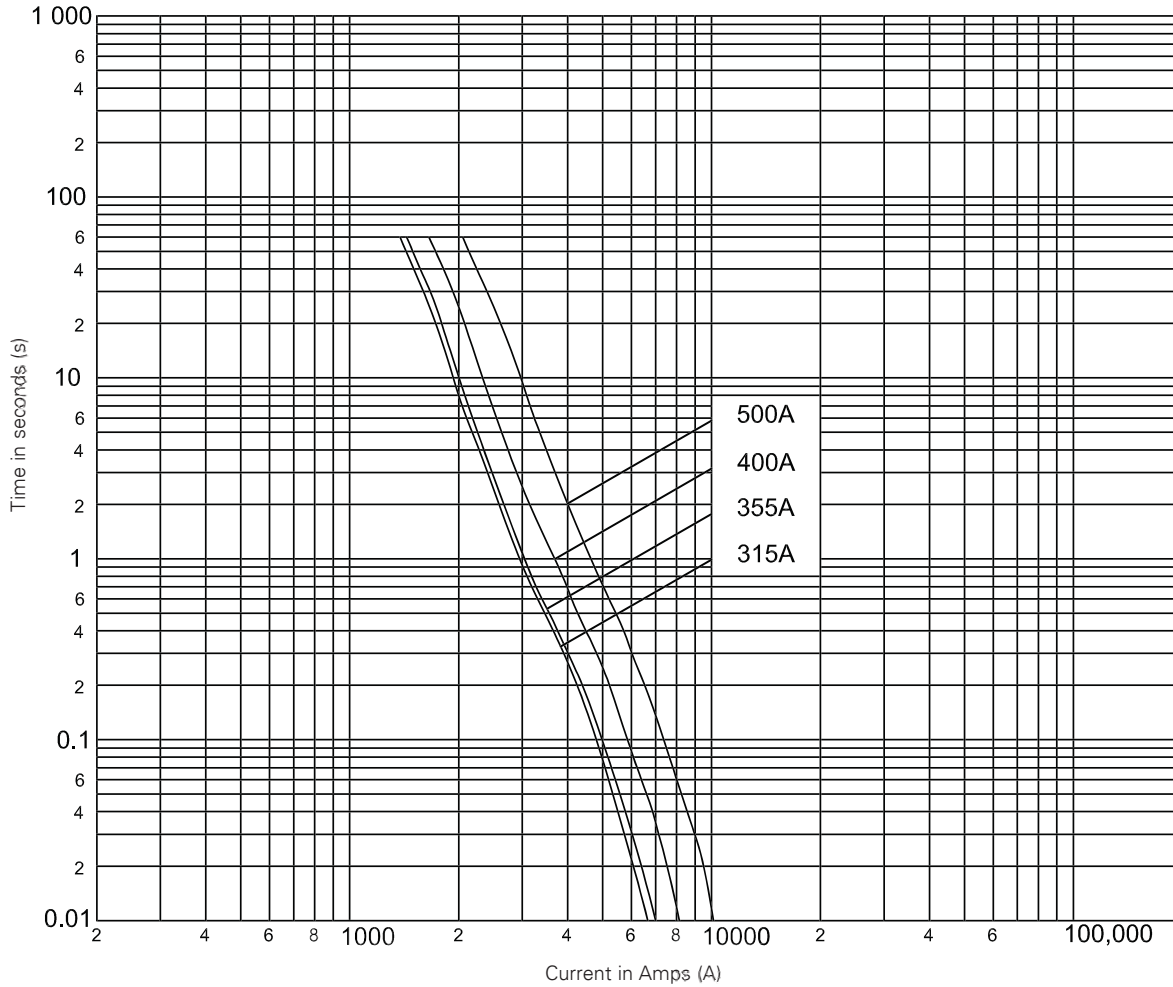

Technical data

500 V a.c.	690 V a.c.	Fuse Link Size	Current (Amps)	I ² t (Amps ² Seconds)		Watts Loss (W)	Net Weight Per Fuse (Kg)
Catalogue Numbers With Metal Gripping Lugs	Catalogue Numbers With Metal Gripping Lugs			Minimum Pre-Arcing	*I ₁ 120 kA at 690 V a.c.		
315NHM3B	315NHM3B-690	3	315	480,000	1,600,000	20	1.050
355NHM3B	355NHM3B-690		355	500,000	1,300,000	27	
400NHM3B	400NHM3B-690		400	680,000	2,000,000	28	
500NHM3B	500NHM3B-690		500	1,050,000	2,800,000	36	

* I₁ is the maximum breaking capacity test at Voltage according to IEC 60269-1 and 2 requirements

NH Fuse bases and accessories - SD and TD series

Description

NH fuse bases with thermoplastic bodies, DIN rail and/or screw mounting (size 4 screw mounting only). Range of accessories including phase barriers, IP20 finger-safe protection kits and neutral links available.

Microswitch also available for remote signaling of fuse link operation.

Catalogue numbers structure

- SD(size)-D, SD(size)-S: 1-pole
- TD(size)-D, TD(size)-DI: 3-pole.

Standards / approvals

- IEC 60269-1 and 2, VDE 0636-1 and 2.

Technical data

- Voltage: 690 V a.c.
- Current: 160 to 1600A
- Rated for fuse links with breaking capacity: 120 kA

Compatible fuse links

- NH 400, 500 and 690 V a.c. NH gG and aM fuse links

Packaging

- 1-pole: 3, SD4 and 3-pole: 1
- Packaging 100% recyclable

Features

- Complies with IEC 60269-1 and 2 fuse system A (NH base), manufacturers type test certificates of compliance available.
- 3-pole integral NH00 base available with reduced width.
- Clip-in phase barriers, terminal shrouds and fuse covers available.
- Vibration tested to IEC 60068-2-6 for marine use.



Fuse base catalogue numbers

Size	Poles	Current (Amps)	Catalogue Numbers		Pack Quantity	Compatible Fuse Links Size
			DIN-Rail and Screw Mounting	Screw Mounting Only		
00	1-pole	160	SD00-D	SD00-S	3	400/500/690 V NH gG and aM fuse links
	3-pole	160	TD00-D	N/A	1	
		160	TD00-DI*	N/A	1	
1	1-pole	250	SD1-D	SD1-S	3	
	3-pole	250	TD1-D	N/A	1	
2	1-pole	400	SD2-D	SD2-S	3	
		400	SD2-DD**	N/A	3	
	3-pole	400	TD2-D	N/A	1	
		400	TD2-DD**	N/A	1	
3	1-pole	630	SD3-D**	SD3-S	3	
	3-pole	630	TD3-D**	N/A	1	
4	1-pole	1250	N/A	SD4-S	1	
		1600	N/A	SD4-S1600	1	

* 3-pole integral base moulding.

** Double fuse contact clips.

NH Fuse bases and accessories - SD and TD series

Technical data

Fuse Base Catalogue Numbers		SD00-D TD00-D TD00-DI	SD1-D TD1-D	SD2-D TD2-D	SD3-D TD3-D	SD4-S	SD4-S1600
Base		Glass filled PBT					
Contacts		Silver plated copper					
Screw, nuts and washers		Zinc clear plated steel					
Derating temperature factors for maximum current	≤ 35°C	1	1	1	1	1	1
	40°C	0.95	0.95	0.95	0.95	0.95	0.95
	50°C	0.85	0.85	0.85	0.85	0.85	0.85
Maximum power acceptance		12W	32W	45W	60W	110W	145W
Degree of protection with covers fitted		IP20	IP20	IP20	IP20	-	-
Terminal screw		M8	M10	M10	M12	M16	M16
Maximum tightening torque terminal screw		10N•m	32N•m	32N•m	32N•m	56N•m	56N•m
Fixing	DIN-Rail	✓	✓	✓	✓	✗	✗
	Screw	✓	✓	✓	✓	✓	✓
With microswitch 16A/250V	Fuse operated signal	✓	✓	✓	✓	✗	✗
Operating temperature range		-20 to 70°C					
Storage temperature range		-40 to 80°C					

Solid links catalogue numbers

Size	Current (Amps)	Catalogue Numbers	Pack Quantity
NH00	160	SDL-00	3
NH1	250	SDL-1	3
NH2	400	SDL-2	3
NH3	630	SDL-3	3



Solid link

Accessories

Fuse extraction handle			
Size	Current (Amps)	Catalogue Numbers	Pack Quantity
NH00-3	160 - 630	FEH	1



Fuse extraction handle

Shroud kits				
Fuse Base Series	Fuse size	Current (Amps)	Catalogue Numbers	Description
SD1	NH1	250	SD12-SK	Kit includes 2 shrouds and 1 fuse cover
SD2	NH2	400	SD12-SK	
SD3	NH3	630	SD3-SK	



Shroud kit

NH Fuse bases and accessories - SD and TD series

Size	Current (Amps)	Phase Barrier Kit		Description
		Catalogue Numbers	Pack Quantity	
NH00	160	SD00-PB	1	2-Phase barriers
NH1	250	SD12-PB	1	2-Phase barriers and 2 ganging links
NH2	400	SD12-PB	1	
NH3	630	SD3-PB	1	



Phase barrier



Ganging link

IP Protection Kits

Size	Current (Amps)	Catalogue Numbers	Fuse Cover	Shroud	Phase Barrier	Ganging Link	Integral Kit	Description
NH00	160	TD00-IP20	3	6	2			Triple pole protection kit for TD00-D with shrouds, fuse covers and phase barriers
		TD00-IP20I					1	Integral triple pole protection kit for TD00-DI with molded shrouds and phase barriers
		TD00-IP20IC	3				1	Integral triple pole protection kit for TD00-DI with fuse covers and molded shrouds and phase barriers
NH1	250	TD1-IP20	3	6	2	2		Triple pole protection kit with terminal shrouds, fuse cover phase barriers and ganging links
NH2	400	TD2-IP20						
NH3	630	TD3-IP20						



TD00-IP20



TD00-IP20I



TD00-IP20IC



TD(size 1 to 3)-IP20

Microswitch

Catalogue Numbers	Pack Quantity	Ratings
BVL50	1	6 A 250 V a.c.
170H0236	12	2 A 250 V a.c.
170H0238	12	2A 250 V a.c.



BVL50



170H0236

Microswitch suitable for the following NH fuse links:

- 400 Volts gG/gL
- 500 Volts gG/gL and aM
- 690 Volts gG/gL and aM.

Note: Microswitches fit onto the fuse gripping lugs and are applicable to all NH size Bussmann fuses.

Data sheet 10163

NH Fuse bases and accessories - SD and TD series

Dimensions (mm) 1-pole, size 00

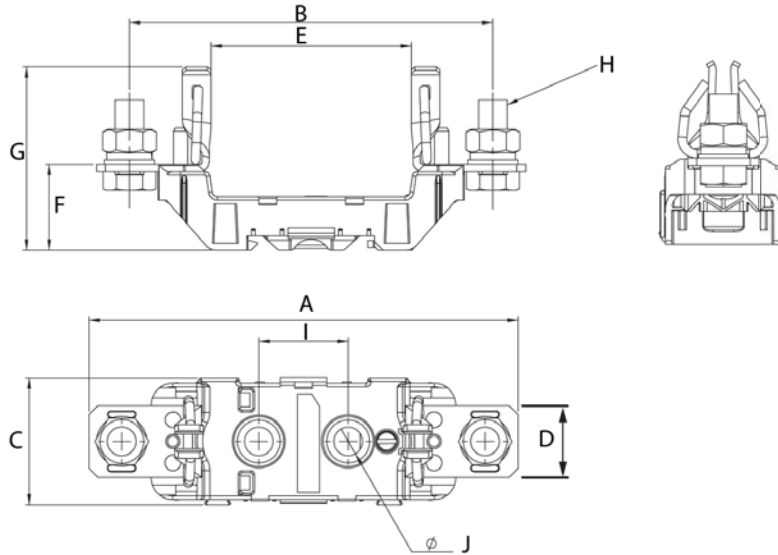

Size	Pole	A	B	C	D	E	F	G	H	I	J
NH00	1-pole	120	102	35.5	20	56	24	51	M8x20	25	8

Dimensions (mm) 1-pole, sizes 1, 2 and 3

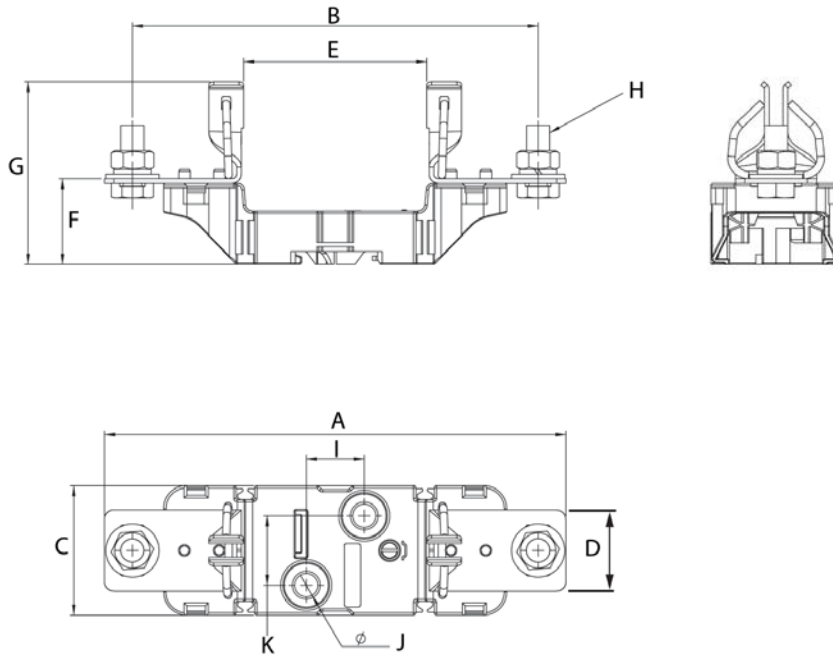

Size	Poles/Type	A	B	C	D	E	F	G	H	I	J	K
NH1	1-pole	199	175	56	35	79	37	78	M10x25	25	10	30
NH2	1 pole	224	199	56	35	79	37.5	86	M10x25	25	10	30
	1-pole double clip	223	199	56	35	82	37	79	M10x25	25	10	30
NH3	1-pole	239	209	56	36	82	37.5	88	M12x30	25	10	30

NH Fuse bases and accessories - SD and TD series

Dimensions (mm) 1-pole, size 4

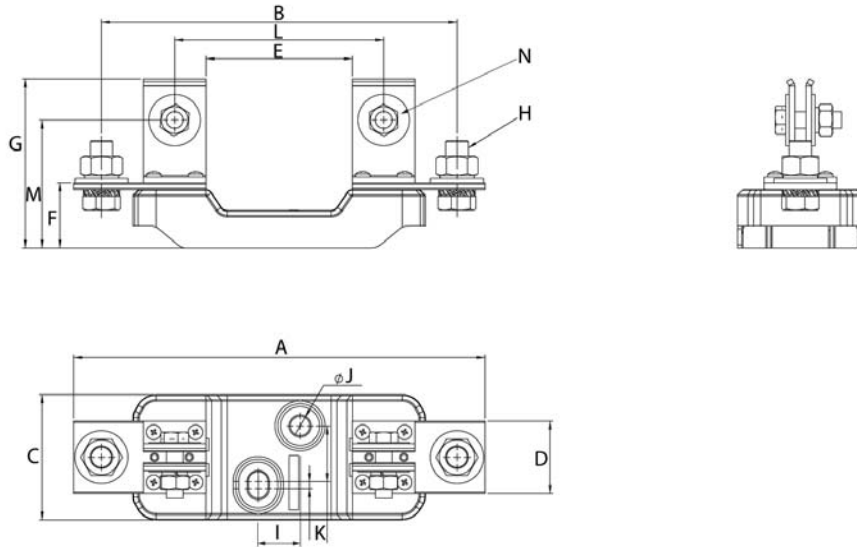

Size	Poles/Type	A	B	C	D	E	F	G	H	I	J	K	L	M	N
NH4	1-pole 1250A	295	255	90	52	105	47	122	M16x40	30	14	40	150	92	M12x40
	1-pole 1600A	295	255	90	60	105	50	125	M16x40	30	14	40	150	92	M12x40

Dimensions (mm) 3-pole, size 00

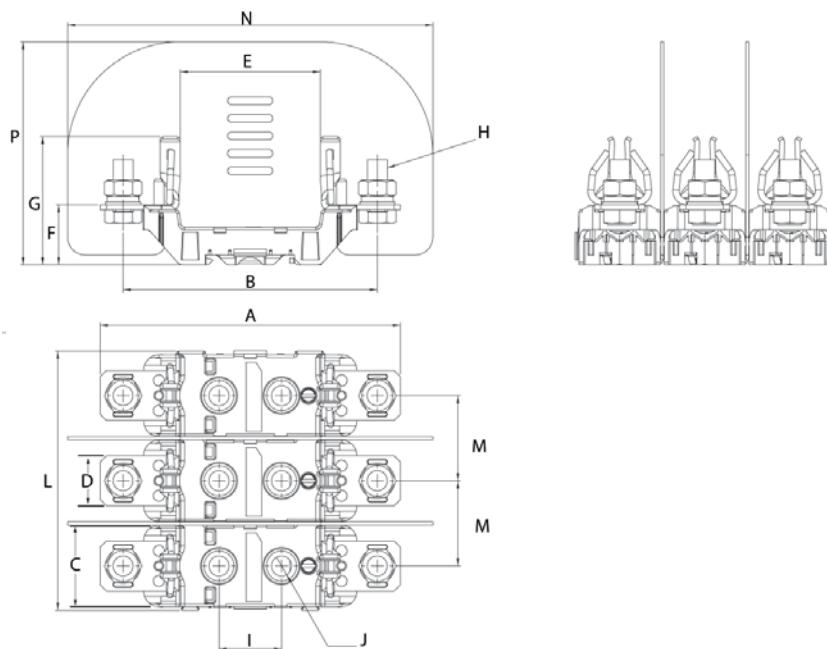

Size	Poles/Type	A	B	C	D	E	F	G	H	I	J	K	L	M	N	P
NH00	3-pole	120	102	35.5	20	56	24	51	M8x20	25	8	-	103.5	34	146	89

NH Fuse bases and accessories - SD and TD series

Dimensions (mm) integral 3-pole, size 00

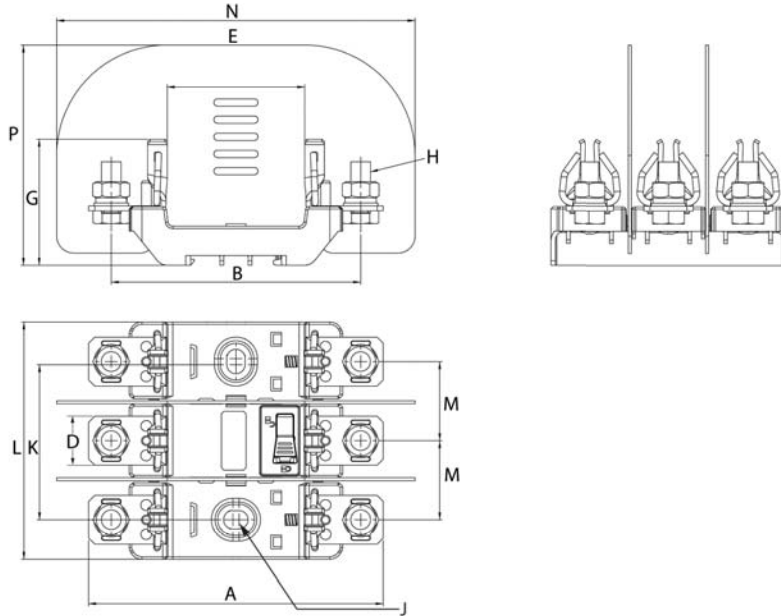

Size	Poles/Type	A	B	C	D	E	F	G	H	I	J	K	L	M	N	P
NH00	3-pole Integral	120	102	-	20	56	24	51	M8x20	-	7.5x10	63.5	97	32.3	146	90

Dimensions (mm) 3-pole, sizes 1, 2 and 3

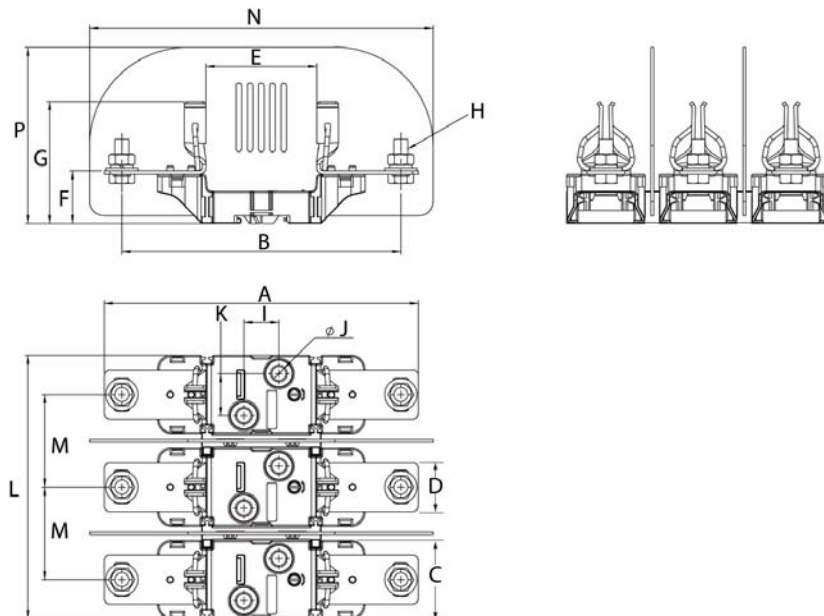

Size	Poles/Type	A	B	C	D	E	F	G	H	I	J	K	L	M	N	P
NH1	3-pole	199	175	56	35	79	37	78	M10x25	25	10	30	188	66	245	125.5
NH2	3-pole	224	199	56	35	79	37.5	86	M10x25	25	10	30	188	66	245	125.5
	3-pole double clip	223	199	56	35	82	37	79	M10x25	25	10	30	188	66	245	125.5
NH3	3-pole	239	209	56	36	82	37.5	88	M12x30	25	10	30	221	82.5	260	137.5

NH Fuse rails - vertical - EBF series

Description

Bussmann's range of NH Fuse rails is specifically designed to be used with NH Fuse links. All energized metal parts are fully protected against accidental contact. They are intended for direct installation on horizontal or vertical busbar systems.

Functionality

- Designed for installation onto 185 mm busbar systems, sizes 00, 1, 2 and 3
- Fuse rail width: size 00 - 50 mm, size 2, 3 - 100 mm
- IP20 Touch protection
- EBF 00/100 mm fuse rails are designed for installation onto 100 mm busbar systems. Installation onto 185 mm busbar system is possible by using an adaptor

Catalogue Numbers structure

- EBF

Standards / approvals

- IEC 60269-1 and CE.

Technical data

- Voltage: 690 V a.c.
- Current:
 - 160 A size 00
 - 400 A size 2
 - 630 A size 3

Compatible fuse links

- NH 400, 500 and 690 V NH gG and aM fuse links



Operating conditions

- Suitable for installation in environments free of any dust, explosive or aggressive gases.
- Altitude up to 2000 metre above sea level
- Can be used in outdoor environments if they are installed in IP34 cabinets
- Relative air humidity should not be higher than 50% temperature of +40°C
- Ambient temperature from -25°C to +55°C

Features

- Possible installation of various earthing devices
- Various options for cable terminations
- Wide range of accessories
- Touch protection IP20 with fuse shrouds

Packaging

- 1 per carton.

Catalogue Numbers							
Size	Current (Amps)	Busbar system	Catalogue Numbers	Cable Terminals	Pack Quantity	Weight	Compatible Fuse Links Size
Vertical fuse rail for NH Size 00							
00	160	100 mm*	EBF00230S8	Bridge terminals with bridge clamps (S) 4 - 70 mm ² , screw terminals with M8 screws	1	1 kg	00
			EBF00230V1	V-Terminals with V-Clamps 25 - 120 SW		1.1 kg	
			EBF00230V0	V Terminals without V-Clamps		1 kg	
		185mm	EBF00330S8	Bridge terminals with bridge clamps (S) 4 - 70 mm ² , screw terminals with M8 screws	1	2 kg	
			EBF00330V1	V-Terminals with V-Clamps 25 - 120 SW		2.2 kg	
			EBF00330V0	V Terminals without V-Clamps		2 kg	
Vertical fuse rail suitable for NH Size 1 and size 2 fuses							
2	400	185 mm	EBF2330V1	V-Terminals with V-Clamps (35 - 240 mm ²)	1	3.2 kg	1 and 2
			EBF2330M1	Screw terminals with pressed nuts M10 (M10 Screw)		3.1 kg	
			EBF2330W1	2V-Terminals with double V-Clamps (2 x 50 - 240 mm ²)		3.8 kg	
Vertical fuse rail suitable for NH Size 3 fuses							
3	630	185 mm	EBF3330V1	V-Terminals with V-Clamps (70 - 300 SW)	1	4 kg	3
			EBF3330M1	Screw terminals with pressed nuts M12 (M12 Screw)		3.1 kg	
			EBF3330W1	2V-Terminals with double V-Clamps (2 x 50 - 240 mm ²)		4.8 kg	

* EBF 00 - 100 mm fuse rails are designed for installation onto 100 mm busbar systems. Installation onto a 185 mm busbar system is possible by using an adaptor

NH Fuse rails - vertical - EBF series

Technical data

Type		EBF 00 100 mm	EBF 00 185 mm	EBF 2	EBF3
Size		00	00	2	3
Rated thermal current $I_{th} = I_n$	A	160	160	400	630
Voltage U_n	V	690	690	690	690
Rated insulation voltage U_i	V	1000	1000	1000	1000
Rated frequency	Hz	50 - 60	50 - 60	50 - 60	50 - 60
Rated power dissipation	W	12	12	45	60
Rated short-circuit withstand current	kA	100	100	100	100
Mechanical durability	Number of cycles	100	100	100	100
Weight	kg	0.75	2	4.5	5
IP Degree of protection	IP	00	00	20 ¹	20 ¹
Size of fuse links		00	00	2	3

1 With fuse links shrouds

Dimensions (mm) - EBF 00 100 mm busbar system

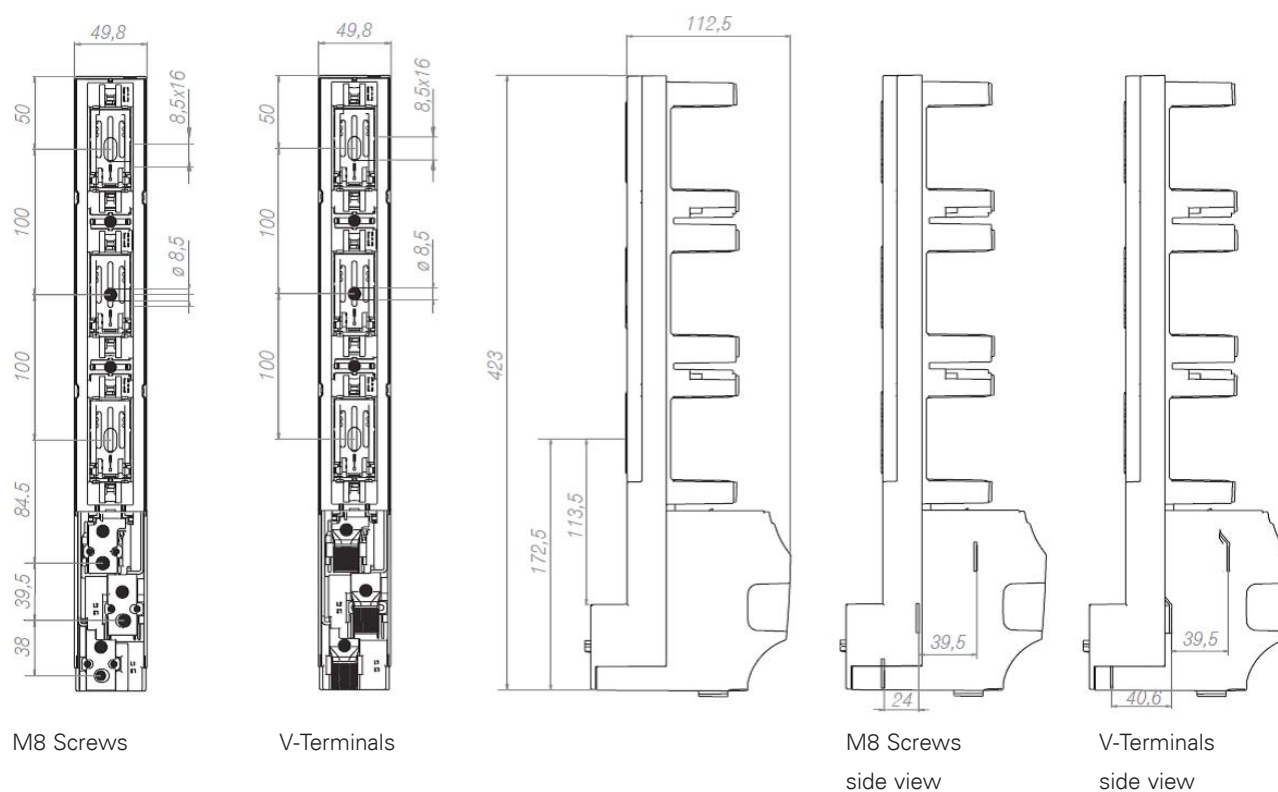

NH Fuse rails - vertical - EBF series

Dimensions (mm) - EBF 00 185 mm busbar system

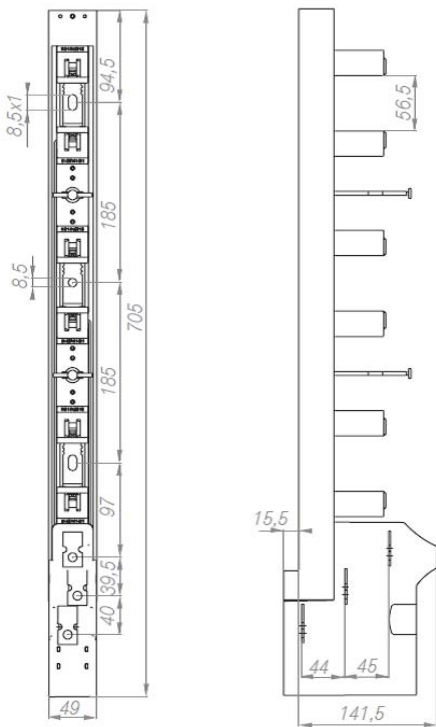

M8 Screws

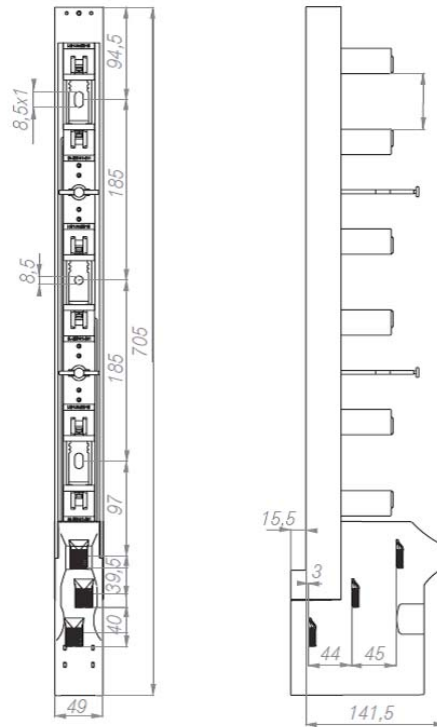

V-Terminals

Dimensions (mm) - EBF 2 and 3

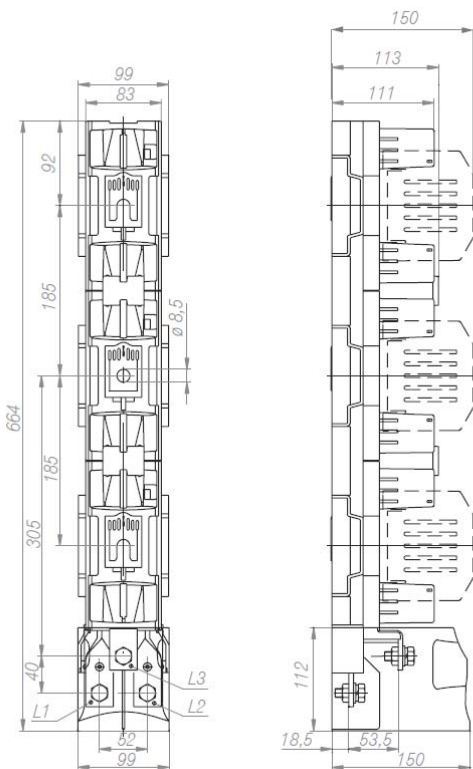

EBF 2 and 3

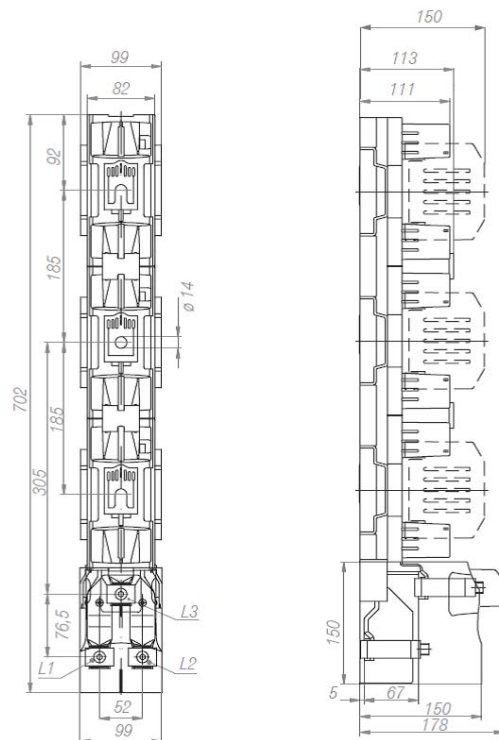

EBF 2 and 3 With terminals 2V (2 x 240 mm²)

NH Fuse switch disconnectors - vertical - EBV series

Description

Eaton's Bussmann series NH Vertical Gear is specifically designed to be used with NH fuse links. All energized metal parts are fully protected against accidental contact. They are suitable for direct installation on horizontal or vertical busbar systems. The three poles can be switched independently or simultaneously depending upon the version. These are manually operated switches and the making and breaking is dependent on the speed of the operation. The EBV series NH gear are provided complete with the clamps (i.e. screws/V-terminals/2V-terminals) and shrouds for cable termination.

Functionality

- Designed for installation onto 100 mm or 185 mm busbar system
- Making and breaking operation should be done with determined movement
- Parallel moving, double contact system
- Suitable for top cable termination connection

Catalogue Numbers structure

- EBV (see table below)

Standards / approvals

- IEC 60947-1 and 3, EN 60947-1 and 3

Technical data

- Voltage: 690 V a.c.
- Current: 160 to 910 A
- Utilisation category:
 - AC21B 690 V a.c. Size 3
 - AC22B 500 V a.c. Sizes 00 to 3
 - AC23B 400 V a.c. Size 00 to 3.

Compatible fuse links

- NH 400, 500 and 690 V gG and aM fuse links.

Busbar mounting options

- Size 00 NH gear are available in two versions suitable for installations onto 100 mm busbar and 185 mm busbar system. 100 mm rails can be installed on the 185 mm busbar system by using an adaptor
- Sizes 1,2 and 3 are suitable for installation onto 185 mm busbar system



Operating conditions

- Suitable for installation in environments free of any dust, explosive or aggressive gases.
- Altitude up to 2000 metre above sea level
- Can be used in outdoor environments if they are installed in IP34 cabinets
- Relative air humidity should not be higher than 50% temperature of +40°C
- Ambient temperature from -25°C to +55°C

Features

- Touch protection IP 30 from the front.
- Top/bottom cable termination possibility
- Test holes provided on the cover to measure the voltage across the link
- Various options for cable terminations
- Wide range of accessories

Packaging

- 1 per carton.

NH Fuse switch disconnectors - vertical - EBV series

Catalogue Numbers							
Size	Current (Amps)	Busbar System	Catalogue Numbers	Cable Terminals	Pack Quantity	Weight	Compatible Fuse Links Size
Vertical fuse switch disconnector for NH Size 00 for 100 mm busbar system - simultaneous 3 phase switching							
00	160	100	EBV0023TS8	Bridge terminals with bridge clamps (s) 4-70mm ² , screw terminals with M8 screws	1	1.3 kg	00
			EBV0023TV1	V-terminals with V-clamps 25-120SW		1.5 kg	
			EBV0023TV0	V-terminals, without V-clamps		1.3 kg	
Vertical fuse switch disconnector for NH Size 00 for 185 mm busbar system - each phase switching separately							
00	160	185	EBV0033SS8	Bridge terminals with bridge clamps (s) 4-70 mm ² , screw terminals with M8 screws	1	2.8 kg	00
			EBV0033SV1	V-terminals with V-clamps 25-120SW		2.9 kg	
			EBV0033SV0	V-terminals, without V-clamps		2.8 kg	
Vertical fuse switch disconnector for NH Size 00 for 185 mm busbar system - simultaneous 3 phase switching							
00	160	185	EBV0033TS8	Bridge terminals with bridge clamps (s) 4-70 mm ² , screw terminals with M8 screws	1	2.7 kg	00
			EBV0033TV1	V-terminals with V-clamps 25-120SW		2.8 kg	
			EBV0033TV0	V-terminals without V-clamps		2.7 kg	
Vertical fuse switch disconnector for NH Sizes 1 and 2 for 185 mm busbar system - each phase switching separately							
2	400	185	EBV233SV1	V-terminals with V-clamps 240 mm ²	1	5.8 kg	1 and 2
			EBV233SM1	Screw terminals with pressed nuts M10		5.7 kg	
			EBV233SW1	2V-terminals with double clamps 240 mm ²		6.4 kg	
			EBV233SV0	V-terminals without V-clamps		5.5 kg	
			EBV233SW0	2V-terminals without double V-clamps		6.9 kg	
Vertical fuse rail suitable for NH Sizes 1 and 2 fuses for 185mm busbar system - simultaneous 3 phase switching							
2	400	185	EBV233TV1	V-terminals with V-clamps 240 mm ²	1	5.8 kg	1 and 2
			EBV233TM1	Screw terminals with pressed nuts M10		5.7 kg	
			EBV233TW1	2V-terminals with double V-clamps 240 mm ²		6.4 kg	
			EBV233TV0	V-terminals without V-clamps		5.5 kg	
			EBV233TW0	2V-terminals without double V-clamps		6.9 kg	
Vertical fuse rail suitable for NH size 3 fuses for 185mm busbar system - each phase switching separately							
3	630	185	EBV333SV1	V-terminals with V-clamps 240 mm ²	1	6.6 kg	3
			EBV333SM2	Screw terminals with pressed nuts M12		6.5 kg	
			EBV333SW1	2V-terminals with double V-clamps 240mm ²		7.2 kg	
			EBV333SV0	V-terminals without V-clamps		6.3 kg	
			EBV333SW0	2V-terminals without double V-clamps		6.7 kg	
Vertical fuse rail suitable for NH size 3 fuses for 185 mm busbar system - simultaneous 3 phase switching							
3	630	185	EBV333TV1	V-terminals with V-clamps 240 mm ²	1	6.6 kg	3
			EBV333TM2	Screw terminals with pressed nuts M12		6.5 kg	
			EBV333TW1	2V-terminals with double V-clamps 240 mm ²		7.2 kg	
			EBV333TV0	V-terminals without V-clamps		6.3 kg	
			EBV333TW0	2V-terminals without double V-clamps		6.7 kg	

NH Fuse switch disconnectors - vertical - EBV series

Technical data

Type		EBV 00/ 100 mm	EBV 00	EBV 2	EBV 3
Rated thermal current with fuse links $I_{th} = I_n$	A	160	160	400	630
Rated thermal current with solid links I_{th}	A	N/A	N/A	600	750
Voltage U_n	V	690	690	690	690
Utilisation category	690 V a.c.	AC-22B	AC-22B	AC-22B	AC-21B
	500 V a.c.	N/A	N/A	N/A	AC-22B
	400 V a.c.	AC-23B	AC-23B	AC-23B	AC-23B
Rated switching current I_e	A	160	160	400	630
Rated short-circuit making current	690 V a.c.	25	80	100	80
	500 V a.c.	25	N/A	100	100
	400 V a.c.	25	100	100	100
Rated short-circuit withstand current	690 V a.c.	100	80	100	80
	500 V a.c.	100	N/A	100	100
	400 V a.c.	100	100	100	100
Rated insulation voltage U_i	V	1000	1000	1000	1000
Rated impulse withstand voltage U_{imp}	kV	8	12	12	12
Rated short time withstand current I_{cw}	kA	N/A	N/A	12 ² / 15 ³)	14 ² / 16 ³)
Rated frequency	Hz	50/60	50/60	50/60	50/60
Mechanical durability	No. of cycles	1600	1600	1000	1000
Electrical durability		200	200	200	200
IP Rating	IP	30	20	30	30
Fuse links size		00	00	1, 2	3

1: fuse link gTr 630 kVA, DIN 43620, VDE 0636/2011 voltage

2 For disconnectors 1-phase disconnected

3: For disconnectors 3-phase disconnectors

Dimensions (mm) - EBV 00 100 mm

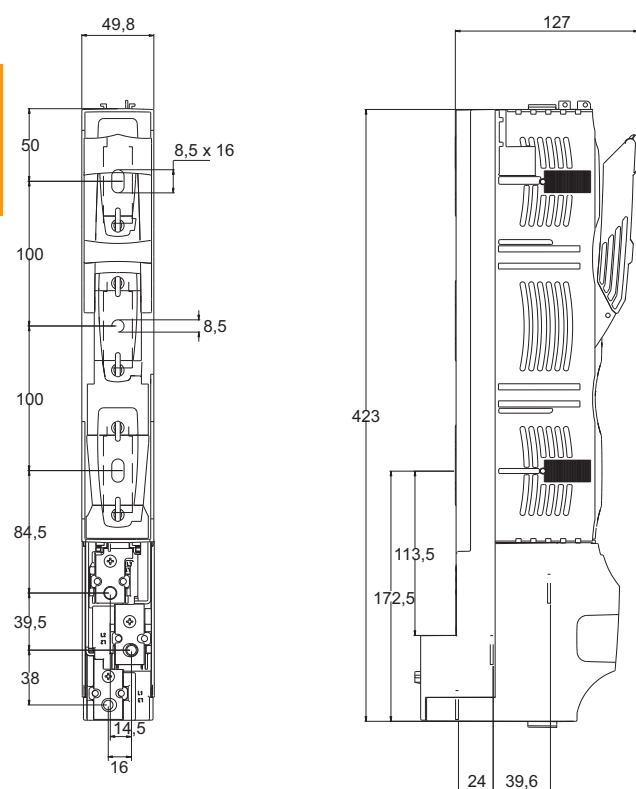

M8 Screws

EBV 00 (each phase switching separately)

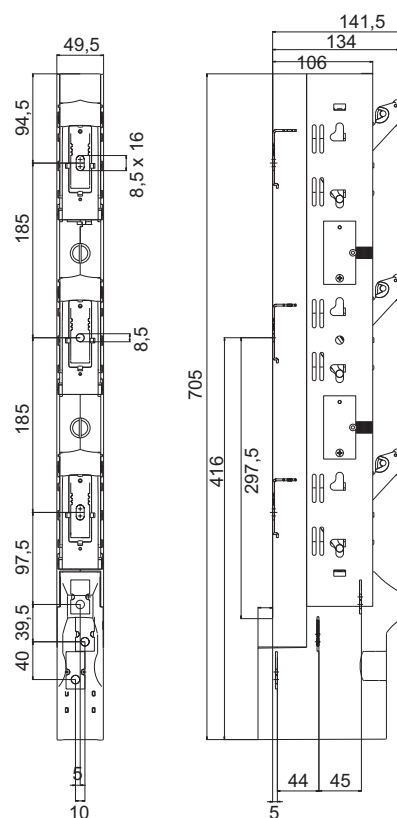

M10 Screws

NH Fuse switch disconnectors - vertical - EBV series

Dimensions (mm) - EBV 00 (Three phase switching simultaneously)

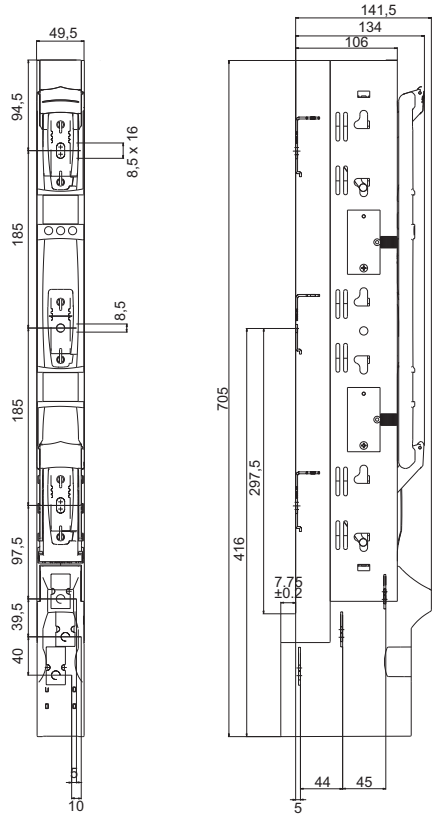

Dimensions (mm) - EBV 2 (Each phase switching separately)

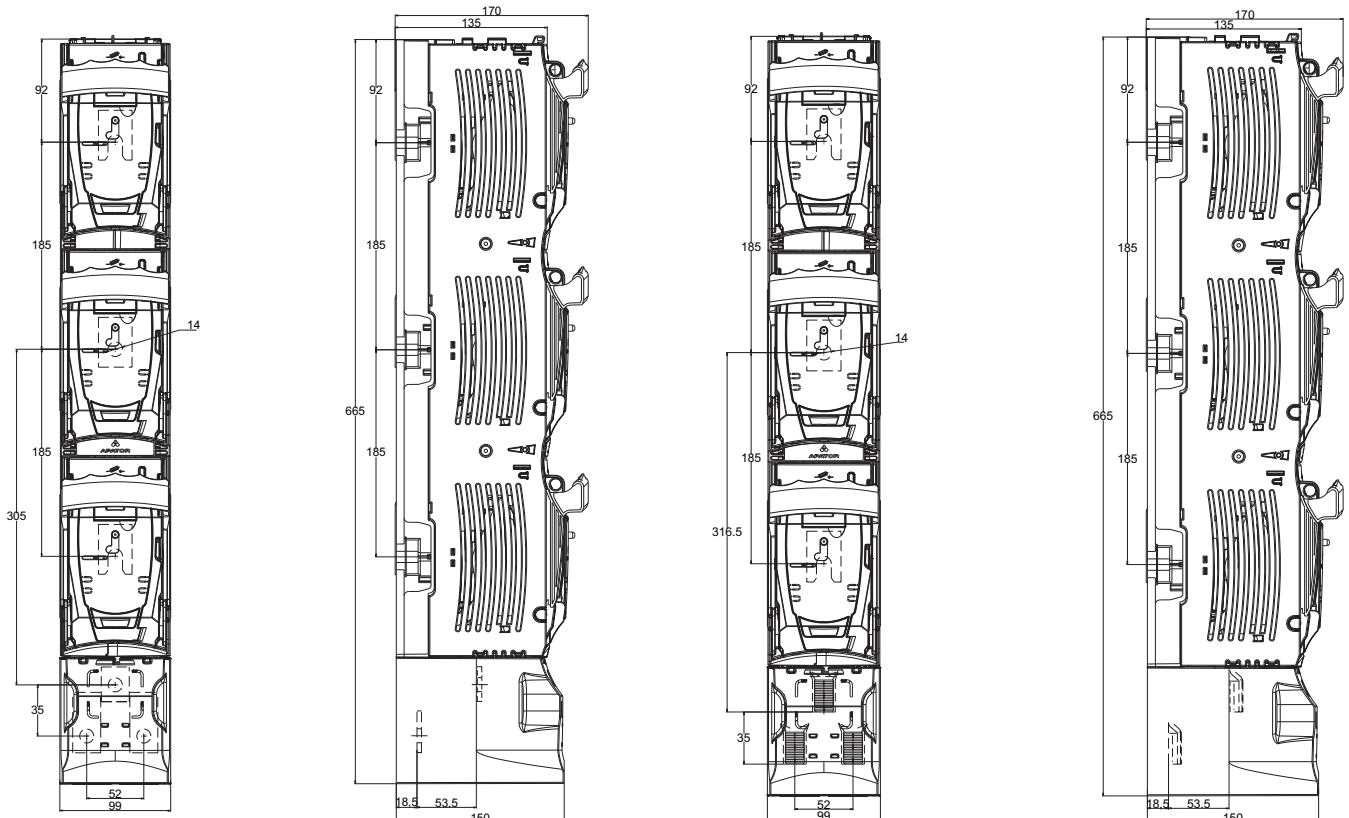

M12 Screws

V-Terminals

Accessories

NH Fuse switch disconnectors - vertical - EBV series

Dimensions (mm) - EBV 2 (Three phase switching simultaneously)

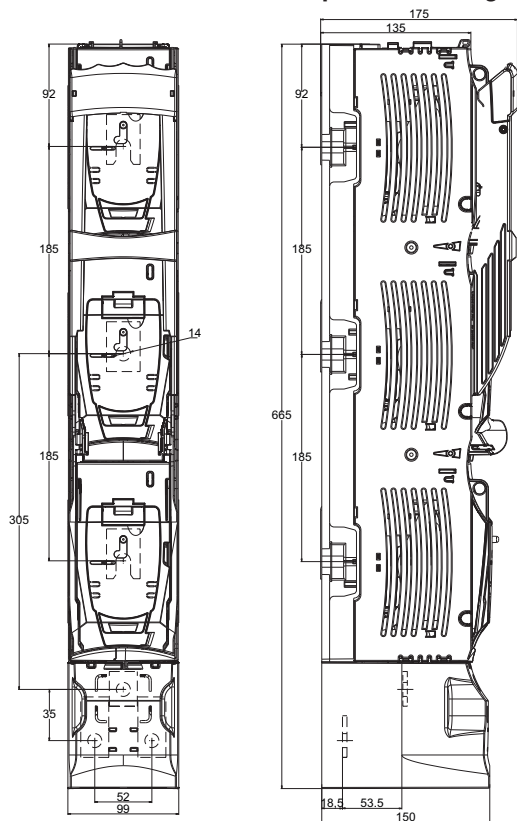

M12 Screws

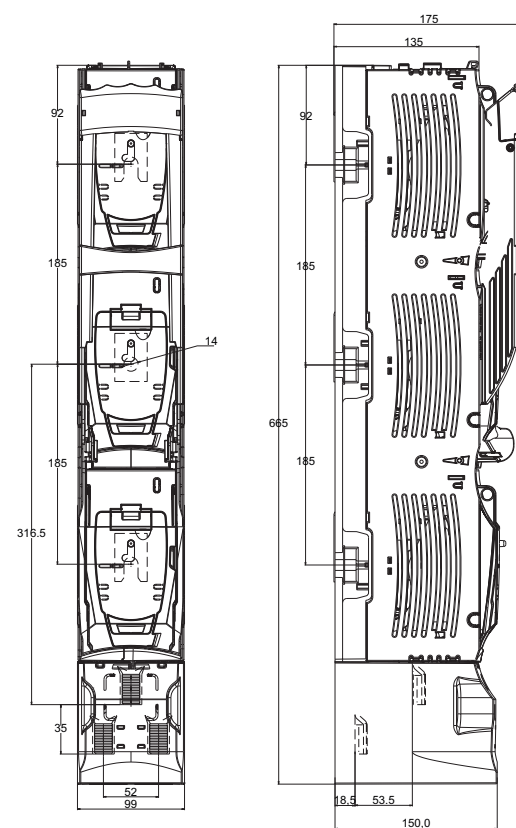

V-Terminals

Dimensions (mm) - EBV 3 (One phase)

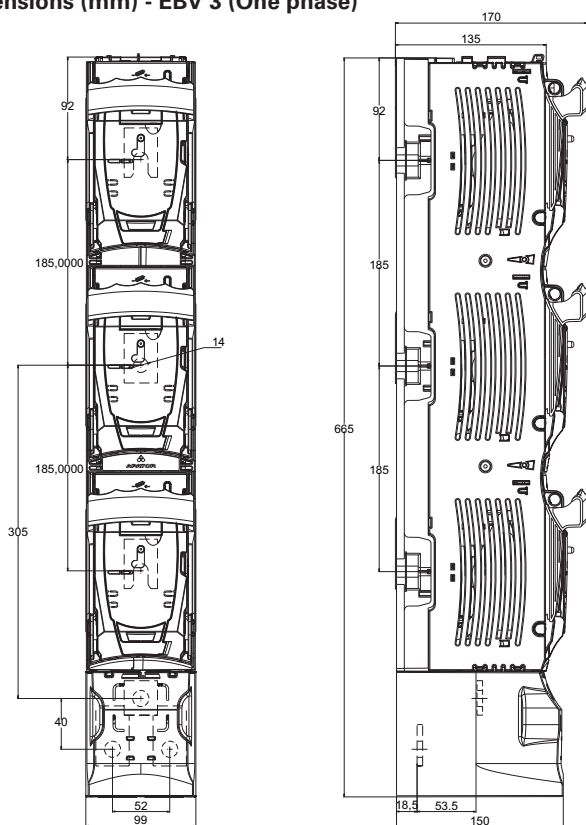

M12 Screws

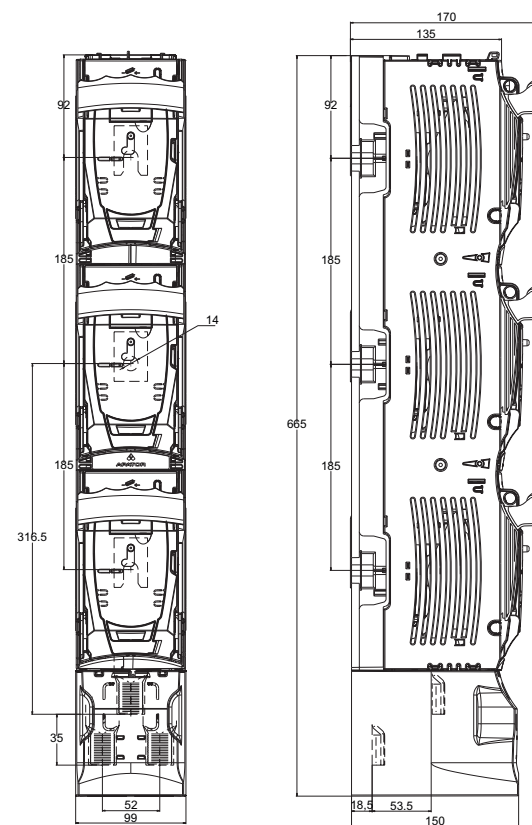

V-Terminals

NH Fuse switch disconnectors - vertical - EBV series

Dimensions (mm) - EBV 3 (Three phase)

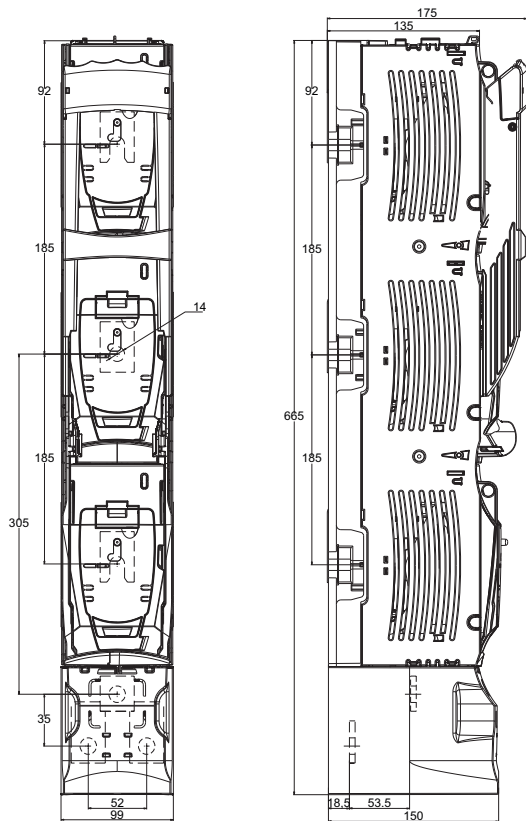

M12 Screws

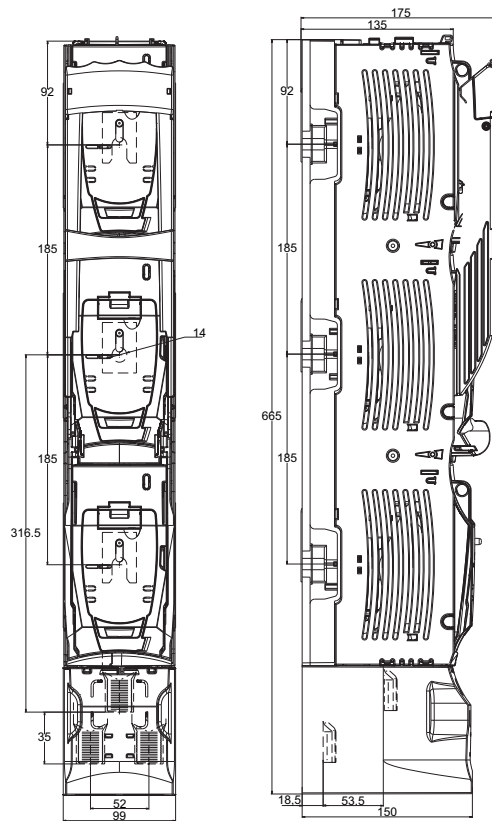

V-Terminals

NH Fuse switch disconnectors - horizontal - EBH000

Description

Bussmann's range of EBH000 NH Horizontal Gear is specifically designed to be used with size 000 NH Fuse links up to 160 A. They have compact dimensions, all energized metal parts are fully protected against accidental contact. These are manually operated switches and the making and breaking is dependent on the speed of the operation.

Functionality

- Designed for installation onto mounting platess, 60 mm or 100 mm busbar systems
- Making and breaking operation should be done with determined movement
- Parallel moving, double contact system
- Suitable for top or bottom cable terminal connection

Catalogue numbers structure

- EBH000 O on mounting plates
- EBH000 1 on 60 mm busbar systems

Standards/approvals

- IEC 60947-1 and 3, EN 60947-1 and 3

Technical data

- Voltage: 690 V a.c.
- Current: 160 A
- Utilisation category:
 - AC21B
 - AC22B
 - AC23B
 - DC21B

Compatible fuse links

- Size 000 NH Fuse links up to 160 A

Mounting options

- On mounting plates: EBH000 O
- On to 60 mm busbar systems: EBH000 1



Operating conditions

- Suitable for installation in environments free of any dust, explosive or aggressive gases
- Altitude up to 2000 metres above sea level
- Can be used in outdoor environments if they are installed in IP34 cabinets
- Relative air humidity should not be higher than 50% temperature of +40°C
- Ambient temperature from -25°C to +55°C

Features

- Touch for IP 30 from the front
- Top/bottom cable termination possibility
- Compact dimensions
- Test holes provided on the cover to measure the voltage across the link
- Various options for cable terminations
- Wide range of accessories)

Packaging

- 1 per carton.

NH Fuse switch disconnectors - horizontal - EBH000

Catalogue Numbers						
Size	Current (Amps)	Busbar System	Catalogue Numbers	Cable Terminals	Pack Quantity	Compatible Fuse Links Size
Horizontal fuse switch disconnector for NH size 000 up to 160 A for installation on mounting plates						
000	160	N/A	EBH00003TS5	for connection of round conductors - S-bridge clamps	1	000 up to 160 A
			EBH00003TS5-D	for connection of round conductors - S-bridge clamps, option to install on DIN rail		
			EBH00003TM8	for connection of round conductors with lug terminals - M8 screws		
			EBH00003TM8-D	for connection of round conductors with lug terminals - M8 screws, option to install on DIN rail		
			EBH00003TS5L	for connection of round conductors - S-bridge clamps, lengthened terminal shrouds		
			EBH00003TM8L	for connection of round conductors with lug terminals - M8 screws, lengthened terminal shrouds		
Horizontal fuse switch disconnector for NH size 000 up to 160 A for installation on 60 mm busbar						
000	160	60 mm	EBH00013TBS5	Cable terminal – bottom, for connection of round conductors - S-bridge clamps	1	000 up to 160 A
			EBH00013TS5	Cable terminal – top, for connection of round conductors - S-bridge clamps		
			EBH00013TM8	Cable terminal – bottom, for connection of conductors with lug terminals - M8 screws		
			EBH00013TTM8	Cable terminal – top, for connection of conductors with lug terminals - M8 screws		

Technical data

		EBH 000				
Rated thermal current with solid links I_{th}	A	160				
Voltage U_n	V	690				
Utilisation category		AC-23B	AC-22B	AC-22B	AC-21B	DC-21B
Rated switching current I_e	A	100	100	160	160	160
Rated switching Voltage U_e	V	400	690	400	690	250
Rated short circuit making current	690 V	100	100	100	100	100
Rated short-circuit withstand current	690 V	25	25	25	25	25
Rated insulation voltage U_i	V	1000	1000	1000	1000	1000
Rated power dissipation	W	12	12	12	12	12
Rated impulse withstand voltage U_{imp}	kV	8	8	8	8	8
Rated frequency	Hz	50-60	50-60	50-60	50-60	50-60
Mechanical durability	Nb of cycles	2000	2000	2000	2000	2000
Electrical durability	Nb of cycles	300	300	300	300	300
IP Rating		IP20	IP20	IP20	IP20	IP20
Fuse links size		000	000	000	000	000



DIN-Rail



Mounting plates



Busbar

NH Fuse switch disconnectors - horizontal - EBH000

Dimensions (mm) - EBH000

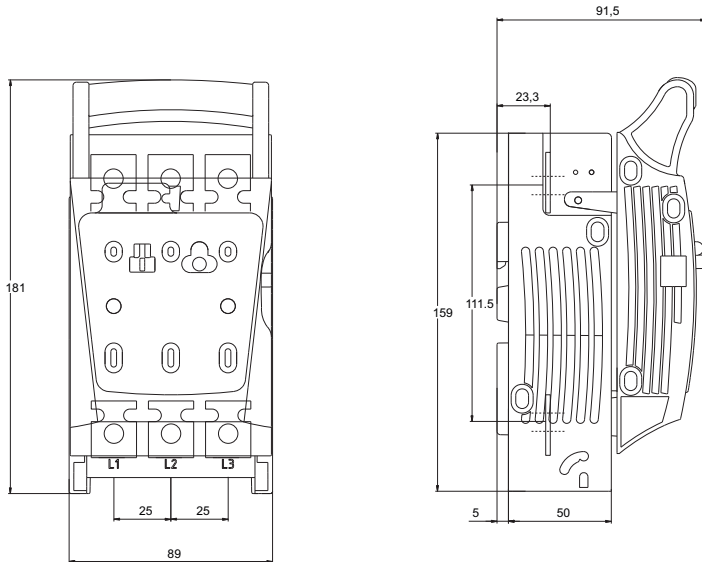

On mounting plates

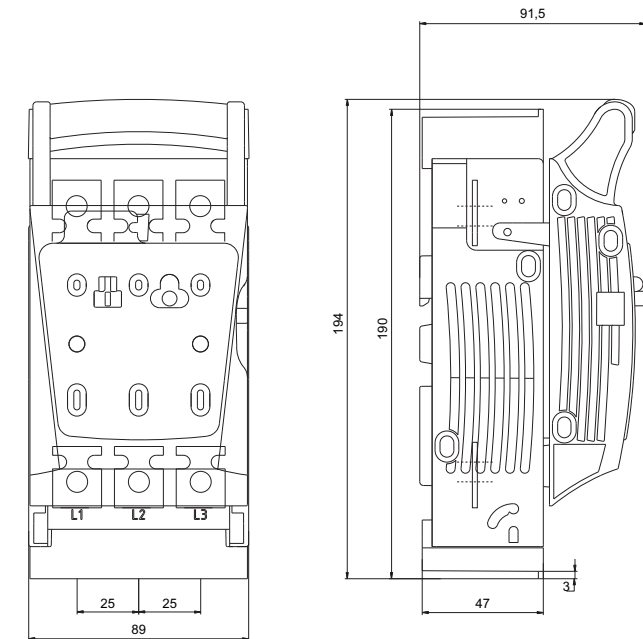

With extended terminal shrouds

Dimensions and spacing of holes for installation on EBH000 O on mounting plates

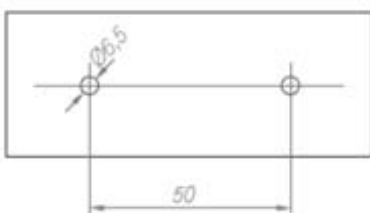

NH Fuse switch disconnectors - horizontal - EBH000

Dimensions (mm) - EBH000 (60 mm busbar mounting)

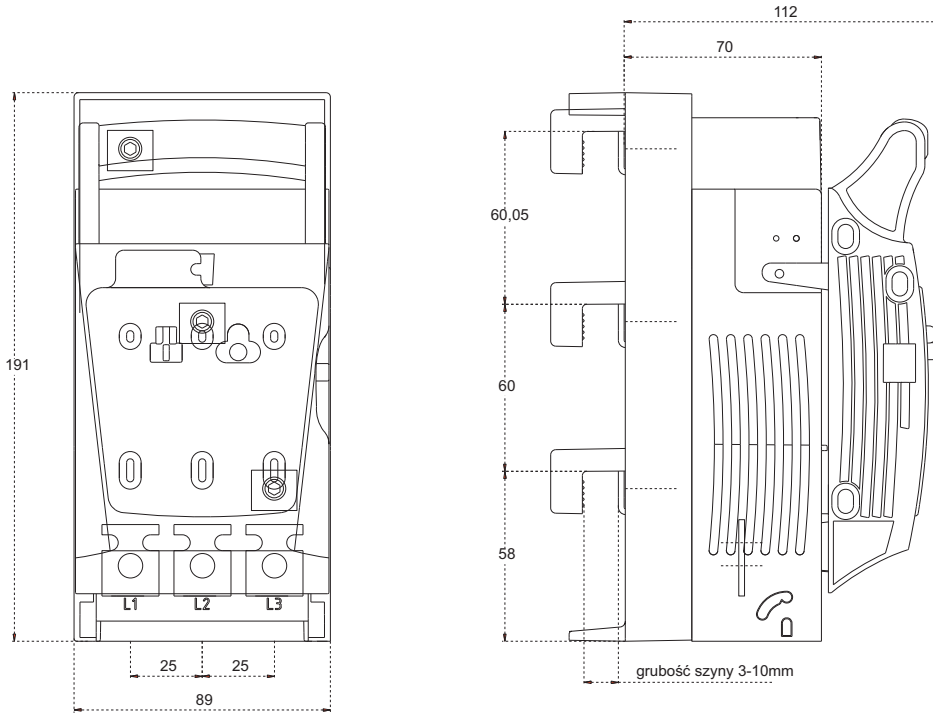

Bottom cable terminal

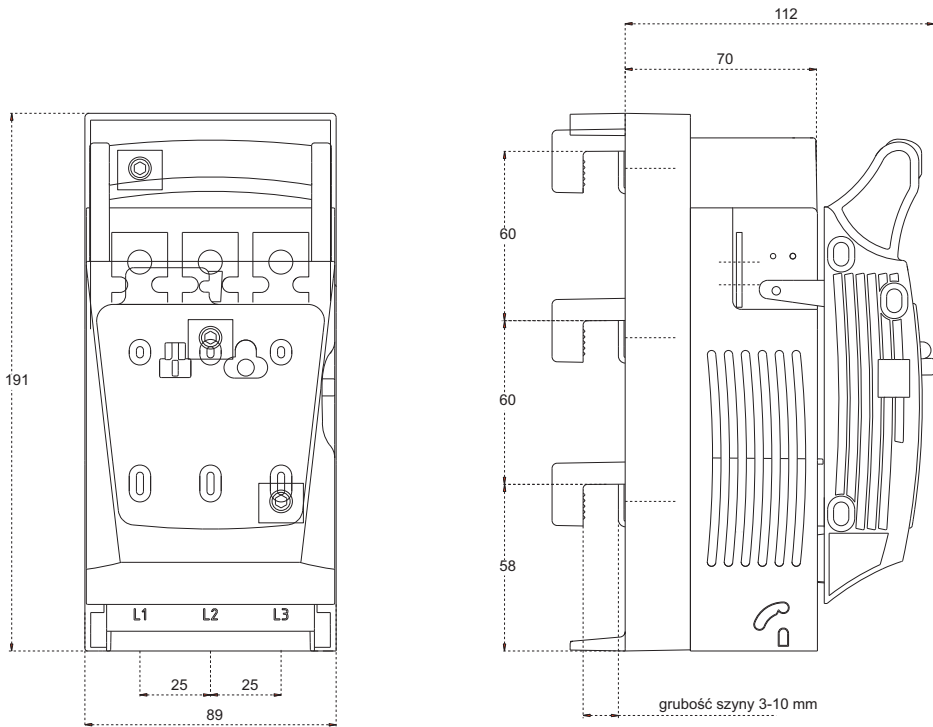

Top cable terminal

NH Fuse switch disconnectors - horizontal - EBH00 to 4

Description

Eatons' Bussmann series NH horizontal fuse switch disconnectors are specifically designed to be used with NH fuse links. All energised metal parts are fully protected against accidental contact. These are manually operated switches and the making and breaking is dependent on the speed of the operation. The EBV series NH gear are provided complete with the clamps (i.e. screws/V-terminals/2V-terminals) and cable for shrouds for cable termination.

Functionality

- Designed for installation onto mounting plates, 60 mm or 100 mm busbar systems
- Making and breaking operation should be done with determined movement
- Parallel moving, double contact system
- Suitable for top or bottom cable terminal connection

Catalogue Numbers structure

- EBH (see catalogue numbers table)

Standards/approvals

- IEC 60947-1 and 3, EN 60947-1 and 3

Technical data

- Voltage: 400, 500 and 690 V a.c.
- Current: 160 to 1600 A
- Utilisation category:
 - AC21B Size 4
 - AC22B Sizes 00 (V 120), 1-S, 3, 4
 - AC23B Sizes 00 to 2
 - DC21B Sizes 00, 2 and 3
 - DC21B Sizes 00, 1 and 2

Compatible fuse links

- NH 400, 500 and 690 V NH gG and aM fuse links

Mounting options

- On mounting plates
 - EBH00 O, EBH1 O, EBH2 O, EBH3 O
- On to busbar systems
 - 60 mm busbar systems: EBH00 1, EBH1 1, EBH2 1 installation on to busbar system with hooked clamps
 - 100 mm busbar systems: EBH2 2, EBH1 2 installation on to busbar system with hooked clamps



Operating conditions

- Suitable for installation in environments free of any dust, explosive or aggressive gases
- Altitude up to 2000 metre above sea level
- Can be used in outdoor environments if they are installed in IP34 cabinets
- Relative air humidity should not be higher than 50% temperature of +40°C
- Ambient temperature from -25°C to +55°C

Features

- Touch for IP 30 from the front
- Top/bottom cable termination possibility
- Test holes provided on the cover to measure the voltage across the link
- Various options for cable terminations
- Wide range of accessories)

Packaging

- 1 per carton.

NH Fuse switch disconnectors - horizontal - EBH00 to 4

Catalogue Numbers						
Size	Current (Amps)	Busbar System	Catalogue Numbers	Cable Terminals	Pack Quantity	Compatible Fuse Links Size
Horizontal fuse switch disconnector for NH size 00 for installation on mounting plates						
00	160	N/A	EBH0003TS5	For connection of round conductors	1	00
			EBH0003TM8	For connection of conductors with lug terminals		
			EBH0003TV1	For connection of sector-shaped conductors		
			EBH0003TS5L	For connection of round conductors, lengthened terminal shrouds		
			EBH0003TM8L	For connection of conductors with lug terminals, lengthened terminal shrouds		
			EBH0003TV1L	For connection of sector-shaped conductors, lengthened terminal shrouds		
Horizontal fuse switch disconnector for NH size 00 for installation on 60 mm busbar						
00	160	60 mm	EBH0013TBM8	Cable terminal - bottom, for connection of conductors with lug terminals	1	00
			EBH0013TTM8	Cable terminal - top, for connection of conductors with lug terminals		
			EBH0013TBF	Cable terminal - top, for connection of conductors with bare ends		
			EBH0013TTF	Cable terminal - bottom, for connection of conductors with bare ends frame clamps		
Horizontal fuse switch disconnector for NH size 1 for installation on mounting plates						
1	250	N/A	EBH103TS8	For connection of round conductors - S-bridge clamps	1	1
			EBH103TM1	For connection of conductors with lug terminals - screws		
			EBH103TV1	For connection of sector-shaped conductors V-clamps		
			EBH103TVS	For connection of round conductors, top terminals, V-terminals, bottom terminals, S-bridge terminals		
			EBH103TVM	For connection of round conductors, top terminals, V-terminals, bottom terminals, screw terminals		
			EBH103TSV	For connection of round conductors, top terminals, S-bridge terminals, bottom terminals, V-terminals		
			EBH103TMV	For connection of round conductors, top terminal, screw terminals, bottom terminals, V-terminals		
Horizontal fuse switch disconnector for NH size 1 for installation on 60 mm busbar						
1	250	60 mm	EBH113TTS8	Top cable terminals, for connection of round conductors, S-bridge clamps	1	1
			EBH113TBS8	Bottom cable terminals, for connection of round conductors, S-bridge clamps		
			EBH113TBM1	Bottom cable terminals, for connection of conductors with lug terminals - screws		
			EBH113TTV1	Top cable terminals, for connection of sector-shaped conductors - V-clamps		
			EBH113TBV1	Bottom cable terminals for connection of sector-shaped conductors - V-clamps		
Horizontal fuse switch disconnector for NH size 1 for installation on 100 mm busbar						
1	250	100 mm	EBH123TTS8	Top cable terminals, for connection of round conductors	1	1
			EBH123TBS8	Bottom cable terminals, for connection of round conductors - S-bridge clamps		
			EBH123TTM1	Top cable terminals, for connection of conductors, with lug terminals - screws		
			EBH123TBM1	Bottom cable terminals, for connection of conductors, with lug terminals - screws		
			EBH123TTV1	Top cable terminals, for connection of sector shaped conductors - V-clamps		
			EBH123TBV1	Bottom cable terminals for connection		
Horizontal fuse switch disconnector for NH size 2 for installation on mounting plates						
2	400	N/A	EBH203TS8	For connection of round conductors - S-bridge clamps	1	2
			EBH203TM1	For connection of conductors with lug terminals - M10 screws		
			EBH203TV1	For connection of sector-shaped conductors - V-clamps		
			EBH203TW1	For connection of sector-shaped conductors - double V-clamps		
Horizontal fuse switch disconnect for NH size 2 for installation on 60 mm busbar						
2	400	60	EBH213TBM1	Bottom cable terminals, for connection of conductors with lug terminals, M10 screws	1	2
			EBH213TTM1	Top cable terminals, for connection of conductors with lug terminals, M10 screws		
			EBH213TBV1	Bottom cable terminals, for connection of sector-shaped conductors, V-clamps		
			EBH213TTV1	Top cable terminals, for connection of sector shaped conductors, V-clamps		
			EBH213TBW1	Bottom cable terminals, for connection of sector shaped conductors, double V-clamps		
			EBH213TTW1	Top cable terminals, for connection of sector shaped conductors, double V-clamps		

1: Please contact Bussmann to discuss specific requirements

NH Fuse switch disconnectors - horizontal - EBH00 to 4

Catalogue Numbers						
Size	Current (Amps)	Busbar System	Catalogue Numbers	Cable Terminals	Pack Quantity	Compatible Fuse Links Size
Horizontal fuse switch disconnector for NH size 2 for installation on 100 mm busbar						
2	400	100 mm	EBH223TBM1	Bottom cable terminals, for connection of conductors with lug terminals, M10 screws	1	2
			EBH223TTM1	Top cable terminals, for connection of conductors with lug terminals, M10 screws		
			EBH223TBV1	Bottom cable terminals, for connection of sector shaped conductors , V-clamps		
			EBH223TTV1	Top cable terminals, for connection of sector shaped conductors, V-clamps		
			EBH223TBW1	Bottom cable terminals, for connection of sector shaped conductors, double V-clamps		
			EBH223TTW1	Top cable terminals, for connection of sector shaped conductors, double V-clamps		
Horizontal fuse switch disconnector for NH size 3 for installation on mounting plates						
3	630	N/A	EBH303TS8	For connection of round conductors, S-bridge clamps	1	3
			EBH303TM2	For connection of conductors with lug terminals, M12 screws		
Horizontal fuse switch disconnector for NH size 3 for installation on 60 mm busbar						
3	630	60 mm	EBH313TM2	For installation on to 60 mm busbar system, top/bottom cable terminals, M12 screws	1	3
Horizontal fuse switch disconnector for NH size 4 for installation on mounting plates						
4a	1250	N/A	EBH403TM2-12	Three phase switching simultaneously	1	4
	1600		EBH403TM2-16	Three phase switching simultaneously		
	1250		EBH403SM2-12	Each phase switching simultaneously		
	1600		EBH403SM2-16	Each phase switching simultaneously		

Technical data - sizes 00, 1 and 2

		EBH 00			EBH 1			EBH 2		
Rated thermal current with solid links I_{th}	A	160			250			400		
Voltage U_n	V	690			690			690		
Utilisation category		AC-23B	DC-21B	DC-22B	AC-23B	AC-22B	DC-22B	AC-23B	DC-21B	DC-22B
Rated switching current I_e	A	160	160	160	250	250	250	400	400	400
Rated switching Voltage U_e	V	690	440	250	400	690	250	690	440	220
Rated short circuit making current	690 V	80	20	20	80	80	25	80	15	20
	400 V	100	20	20	100	100	25	100	15	20
Rated short-circuit withstand current	690 V	80	20	20	80	80	25	80		
	400 V	100	20	20	100	100	25	100		
Rated insulation voltage U_i	V	1000			1000			1000		
Rated power dissipation	W	12			32			45		
Rated impulse withstand voltage U_{imp}	kV	8			8			12		
Rated frequency	Hz	50-60	N/A	N/A	50-60	50-60	N/A	50-60	N/A	N/A
Mechanical durability	No of cycles	1600			1600			1000		
Electrical durability		200			200			200		
IP Rating	IP	20			30			20		
Weight	kg	0.7, 0.9			2.5			3 / 4.5		
Fuse links size		00			1			2		

NH Fuse switch disconnectors - horizontal - EBH00 to 4

Technical data - sizes 3 and 4a

		EBH 3		EBH4a	
Rated thermal current with solid links I_m	A	630		1250	1600
Voltage U_n	V	690		500	400
Utilisation category		AC-22B	DC-21B	AC-22B	AC-21B
Rated switching current I_e	A	630	630	1250	1600
Rated switching Voltage U_e	V	690	250	500	400
Rated short circuit making current	690 V	100	100		
	400 V	100	100		
Rated short-circuit withstand current	690 V	25			
	400 V	25		50	
Rated insulation voltage U_i	V	1000		800	
Rated power dissipation	W	60			
Rated impulse withstand voltage U_{imp}	kV	12		8	
Rated frequency	Hz	50-60	N/A	50-60	
Mechanical durability	No of cycles	1000			
Electrical durability		200			
IP Rating	IP	20			
Weight	kg	5 / 5.9			
Fuse links size		3		4a	

Dimensions (mm) for EBH00 suitable for installation on mounting plates

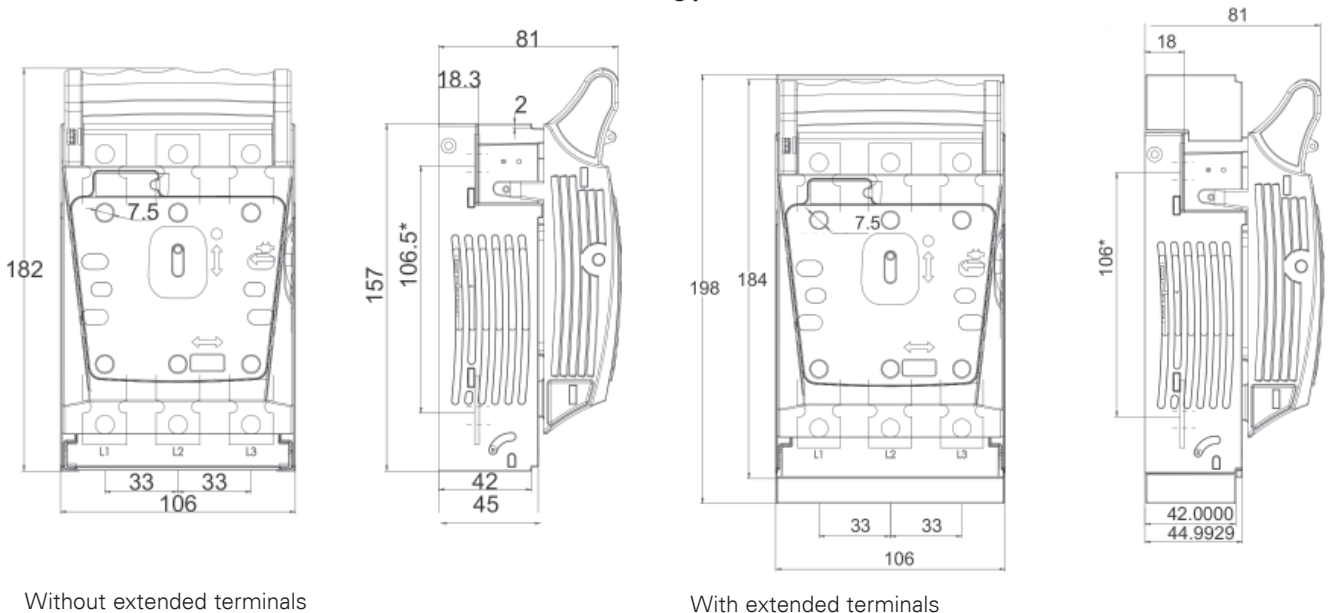

Without extended terminals

With extended terminals

Dimensions and spacing holes for installation on mounting plates

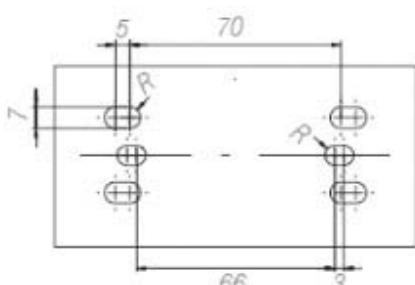

Accessories

NH Fuse switch disconnectors - horizontal - EBH00 to 4

Dimensions (mm) for EBH1 suitable for installation on mounting platess

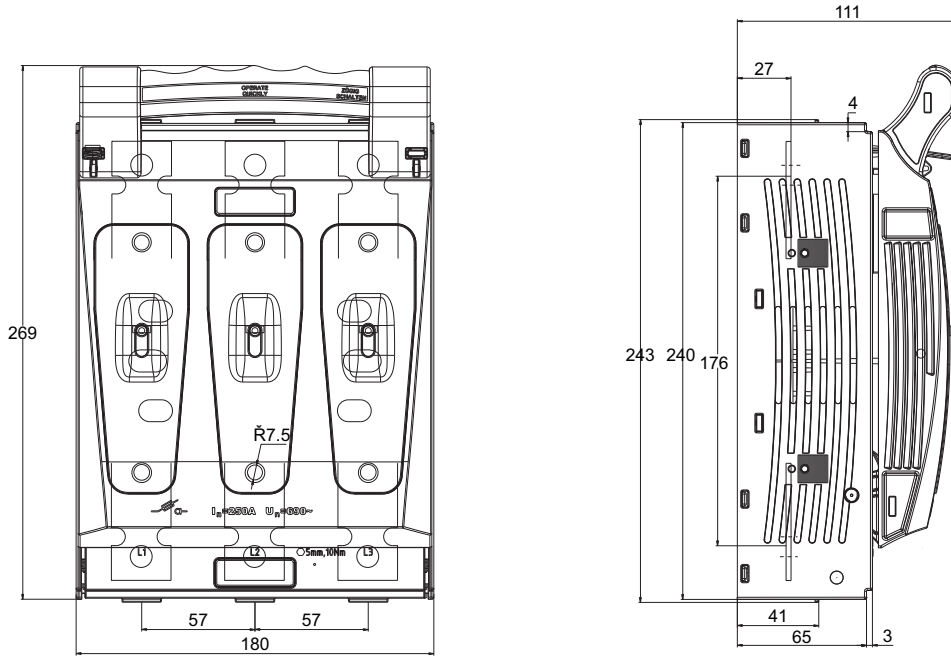

Screw terminals

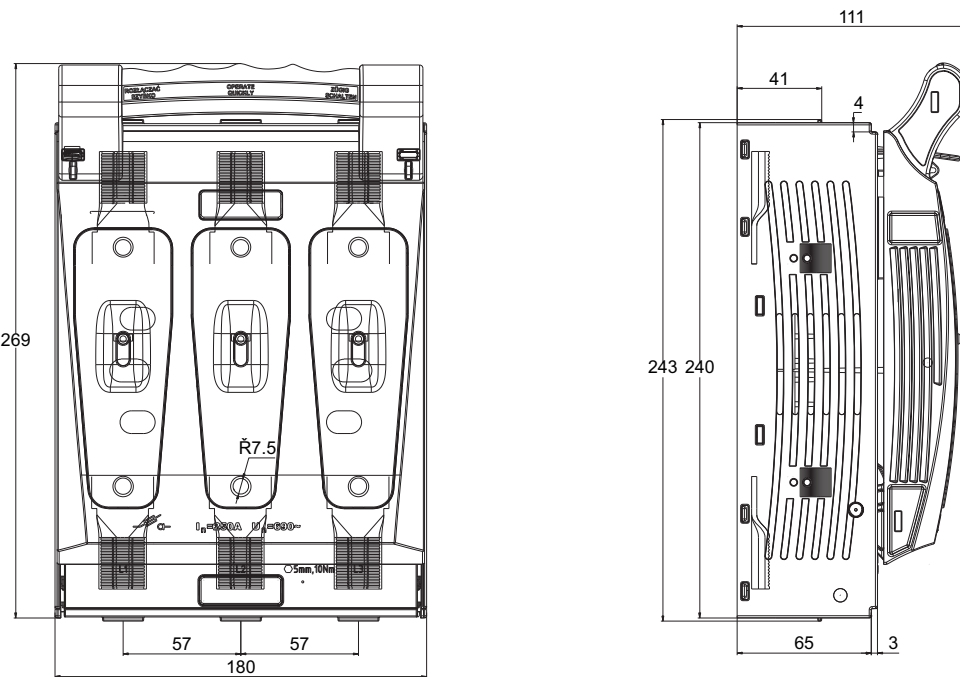

V Clamps

Dimensions and spacing holes for installation on mounting platess

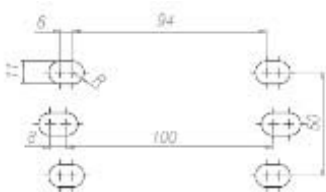

NH Fuse switch disconnectors - horizontal - EBH00 to 4

Dimensions (mm) for EBH1 suitable for installation on 60 mm busbar

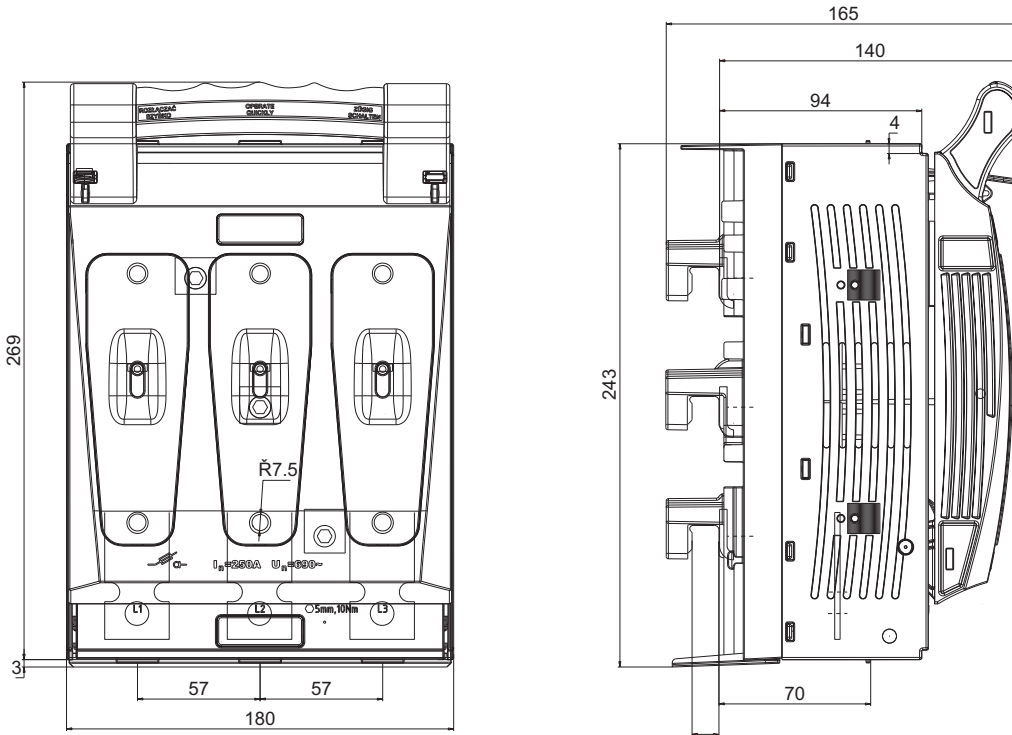

Dimensions (mm) for EBH1 suitable for installation on 100 mm busbar

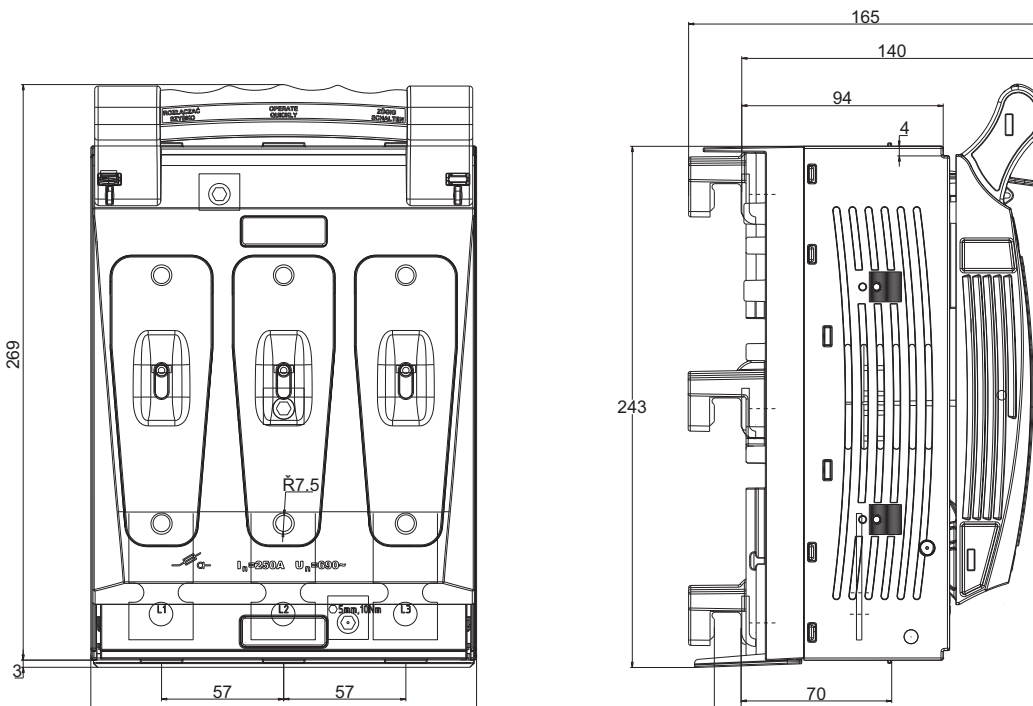

NH Fuse switch disconnectors - horizontal - EBH00 to 4

Dimensions (mm) for EBH2 suitable for installation on mounting platess

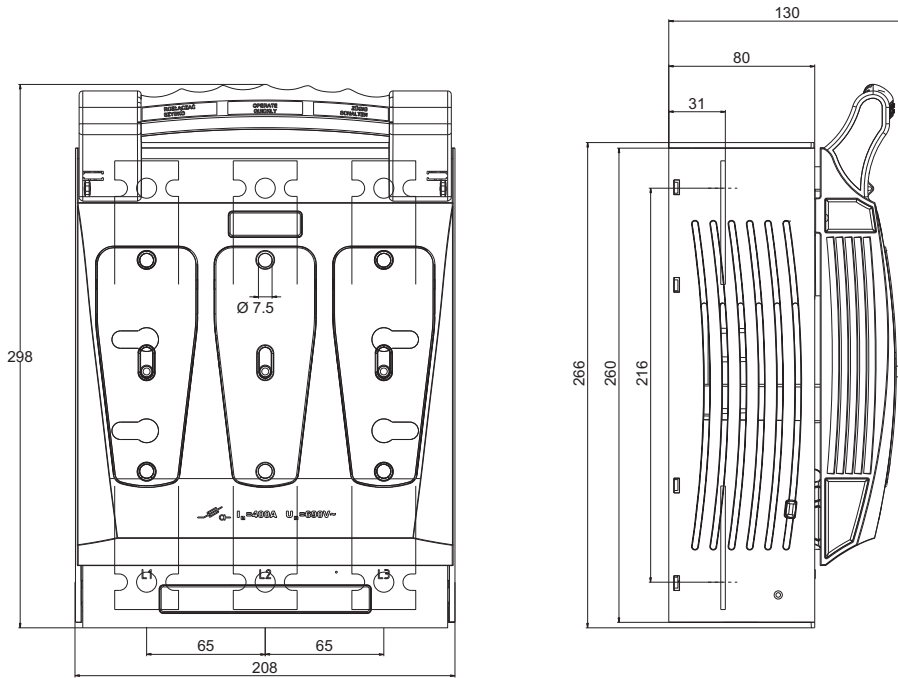

Screw Terminals

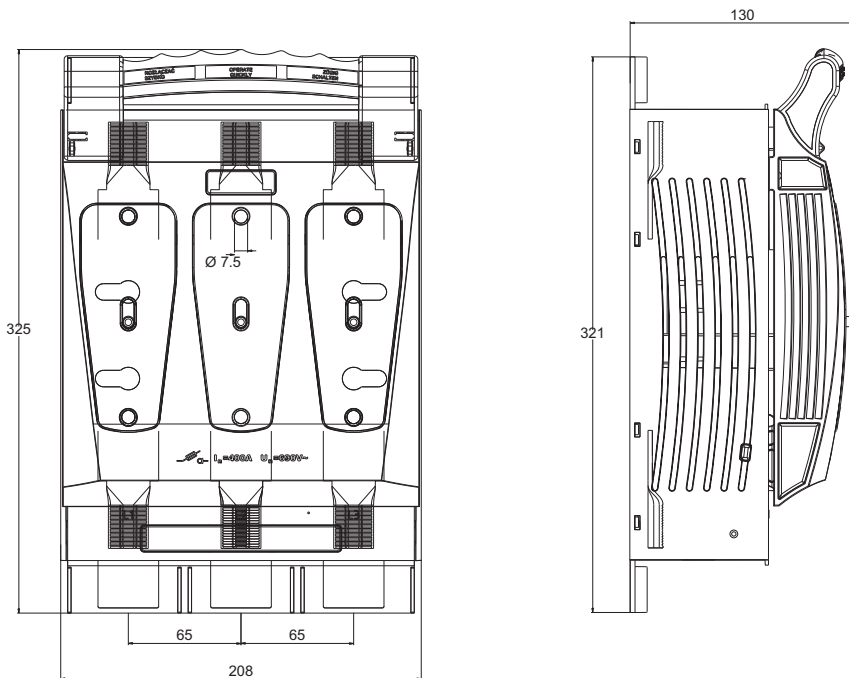

V Terminals

Dimensions and spacing holes for installation on mounting platess

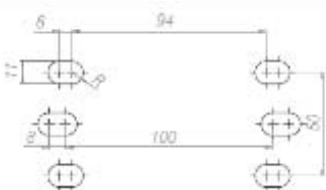

NH Fuse switch disconnectors - horizontal - EBH00 to 4

Dimensions (mm) for EBH2 suitable for installation on 60 mm busbar

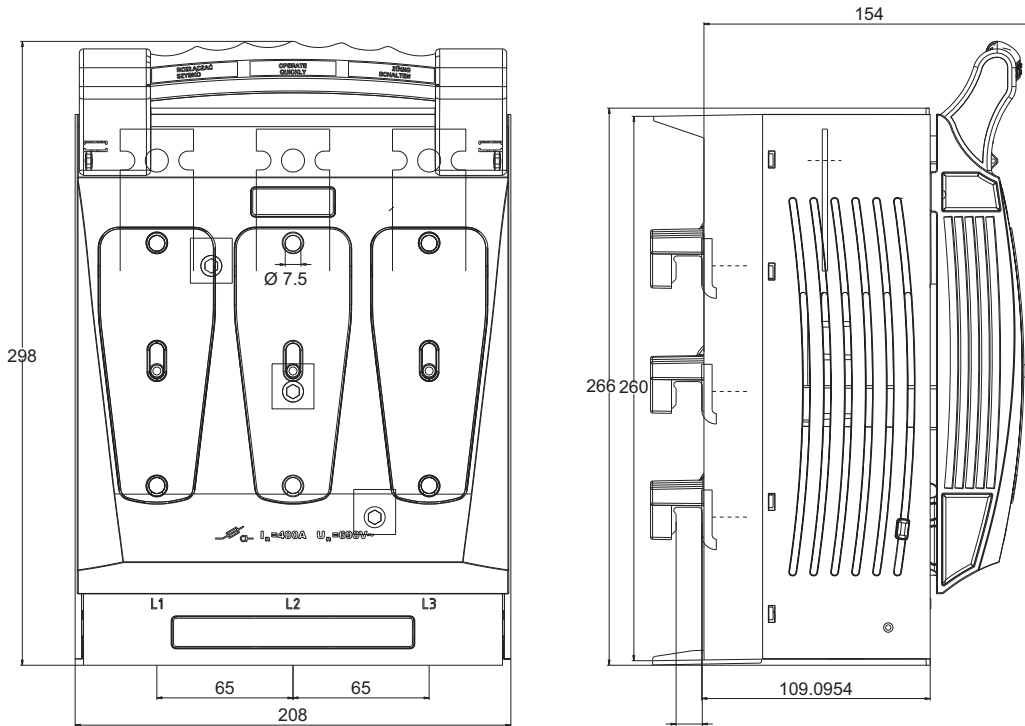

Dimensions (mm) for EBH2 suitable for installation on 100 mm busbar

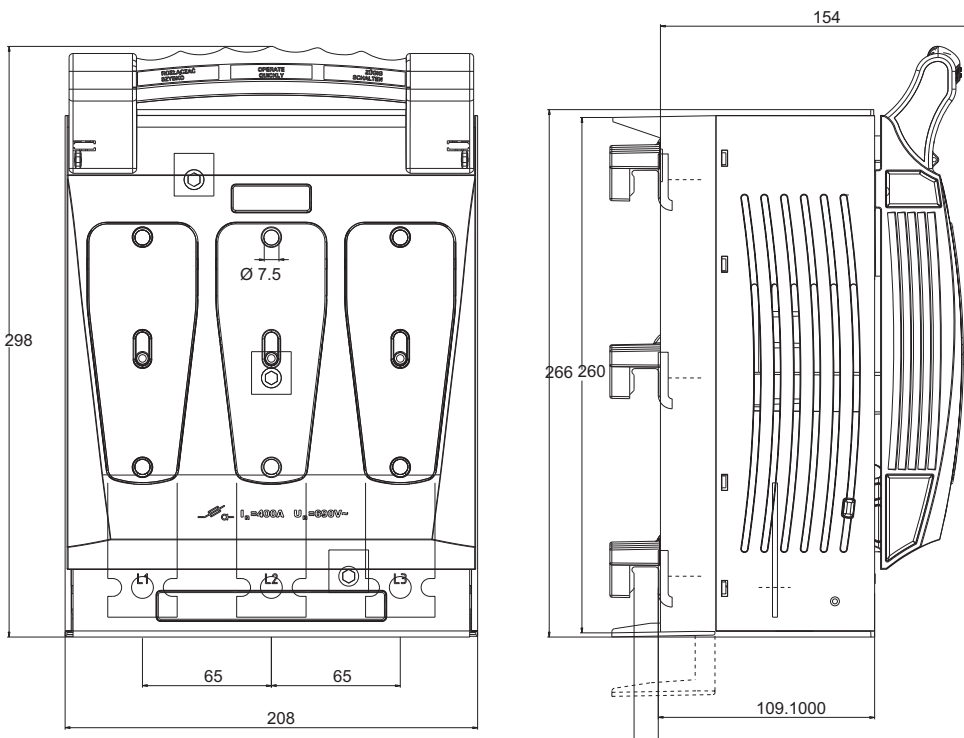

NH Fuse switch disconnectors - horizontal - EBH00 to 4

Dimensions (mm) for EBH3

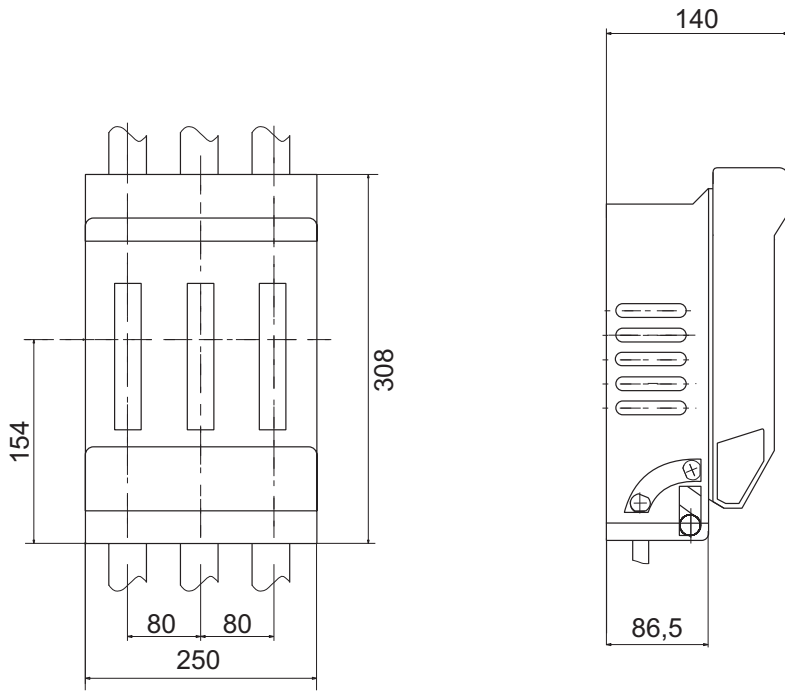

Dimensions (mm) for EBH4

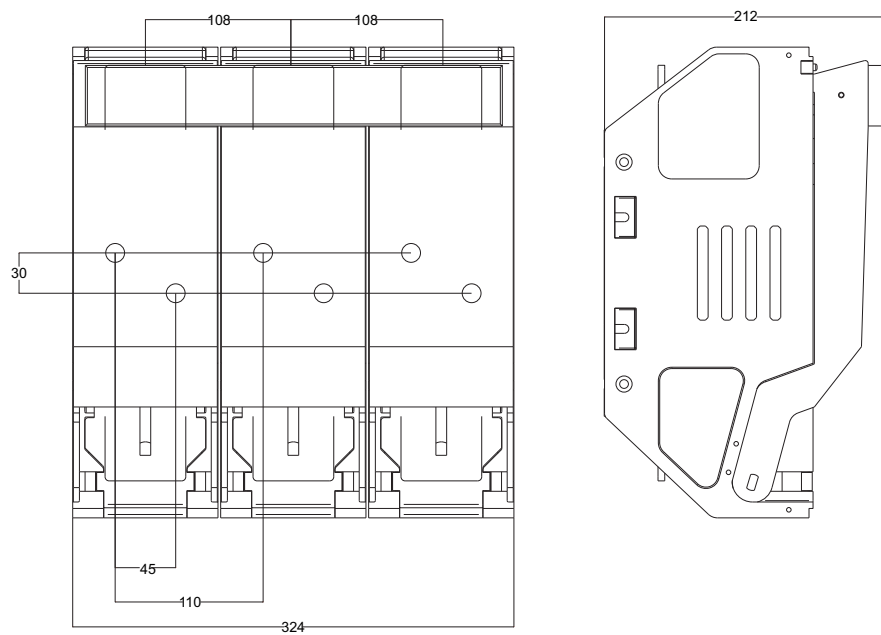

Index - by catalogue numbers

Catalogue number	Size	Voltage	Class	Type	Page
170H0236	N/A	250	N/A	Microswitch	49
170H0238	N/A	250	N/A	Microswitch	49
BVL50	N/A	250	N/A	Microswitch	49
EBF	00 to 3	690	N/A	NH Fuse rails - vertical	53-55
EBH00 to 4	00 to 4	400, 500, 690	N/A	NH Fuse disconnecter - horizontal	66-74
EBH000	000	690	N/A	NH Fuse disconnecter - horizontal	62-65
EBV	N/A	690	N/A	NH Fuse disconnecter - vertical	56-61
FEH	N/A	N/A	N/A	Fuse extraction handle	48
NHG000B	000	500	gG/gL	NH Fuse - Metal	22
NHG000B-400	000	400	gG/gL	NH Fuse - Metal	14
NHG000B-690	000	690	gG/gL	NH Fuse - Metal	34
NHG000BI	000	500	gG/gL	NH Fuse - IMGL	22
NHG000BI-400	000	400	gG/gL	NH Fuse - IMGL	14
NHG00B	00	500	gG/gL	NH Fuse - Metal	23
NHG00B-400	00	400	gG/gL	NH Fuse - IMGL	15
NHG00B-690	00	690	gG/gL	NH Fuse - Metal	35
NHG00BI	00	500	gG/gL	NH Fuse - IMGL	23
NHG00BI-400	00	400	gG/gL	NH Fuse - IMGL	15
NHG01B	01	500	gG/gL	NH Fuse - Metal	25
NHG01B-400	01	400	gG/gL	NH Fuse - Metal	16
NHG01BI	01	500	gG/gL	NH Fuse - IMGL	25
NHG01BI-400	01	400	gG/gL	NH Fuse - IMGL	16
NHG02B	02	500	gG/gL	NH Fuse - Metal	27
NHG02B-400	02	400	gG/gL	NH Fuse - Metal	17
NHG02BI	02	500	gG/gL	NH Fuse - IMGL	27
NHG02BI-400	02	400	gG/gL	NH Fuse - IMGL	17
NHG03B	03	500	gG/gL	NH Fuse - Metal	29
NHG03B-400	03	400	gG/gL	NH Fuse - Metal	18
NHG03BI	03	500	gG/gL	NH Fuse - IMGL	29
NHG03BI-400	03	400	gG/gL	NH Fuse - IMGL	18
NHG0B	0	500	gG/gL	NH Fuse - Metal	24
NHG1B	1	500	gG/gL	NH Fuse - Metal	26
NHG1B-400	1	400	gG/gL	NH Fuse - Metal	16
NHG1B-690	1	690	gG/gL	NH Fuse - Metal	36
NHG1BI	1	500	gG/gL	NH Fuse - IMGL	26
NHG1BI-400	1	400	gG/gL	NH Fuse - IMGL	16
NHG2B	2	500	gG/gL	NH Fuse - Metal	28
NHG2B-400	2	400	gG/gL	NH Fuse - Metal	17
NHG2B-690	2	690	gG/gL	NH Fuse - Metal	37
NHG2BI	2	500	gG/gL	NH Fuse - IMGL	28
NHG2BI-400	2	400	gG/gL	NH Fuse - IMGL	17
NHG3B	3	500	gG/gL	NH Fuse - Metal	30
NHG3B-400	3	400	gG/gL	NH Fuse - Metal	18
NHG3B-690	3	690	gG/gL	NH Fuse - Metal	38
NHG3BI-400	3	400	gG/gL	NH Fuse - IMGL	18
NHG4B-690	4	690	gG/gL	NH Fuse - Metal	39
NHG4G	4	500	gG/gL	NH Fuse - Metal	31
NHM000B	000	500	aM	NH Fuse - Metal	42
NHM000B-690	000	690	aM	NH Fuse - Metal	42
NHM00B	00	500	aM	NH Fuse - Metal	43
NHM00B-690	00	690	aM	NH Fuse - Metal	43
NHM1B	1	500	aM	NH Fuse - Metal	44
NHM1B-690	1	690	aM	NH Fuse - Metal	44
NHM2B	2	500	aM	NH Fuse - Metal	45
NHM2B-690	2	690	aM	NH Fuse - Metal	45
NHM3B	3	500	aM	NH Fuse - Metal	46
NHM3B-690	3	690	aM	NH Fuse - Metal	46
SD-D	1-pole	690	N/A	NH Base	47-52
SDL	N/A	N/A	N/A	Solid link	48
SD-PB	N/A	N/A	N/A	Phase barrier kit	49
SD-S	1-pole	690	N/A	NH Base	47-52
SD-SK	N/A	N/A	N/A	Shroud kit	48
TD-D	3-pole	690	N/A	NH Base	47-52
TD-IP20	N/A	N/A	N/A	IP20 Protection kit	49

IMGL: Insulated Metal Gripping Lugs

Index - by size

Size	Voltage	Catalogue number	Class	Type	Page
0	500	NHG0B	gG/gL	NH Fuse - Metal	24
00	400	NHG00B-400	gG/gL	NH Fuse - IMGL	15
00	400	NHG00BI-400	gG/gL	NH Fuse - IMGL	15
00	500	NHG00B	gG/gL	NH Fuse - Metal	23
00	500	NHG00BI	gG/gL	NH Fuse - IMGL	23
00	500	NHM00B	aM	NH Fuse - Metal	43
00	690	NHG00B-690	gG/gL	NH Fuse - Metal	35
00	690	NHM00B-690	aM	NH Fuse - Metal	43
00 to 3	690	EBF	N/A	NH Fuse rails - vertical	53-55
00 to 4	400, 500, 690	EBH00 to 4	N/A	NH Fuse disconnecter - horizontal	66-74
000	400	NHG000B-400	gG/gL	NH Fuse - Metal	14
000	400	NHG000BI-400	gG/gL	NH Fuse - IMGL	14
000	500	NHG000B	gG/gL	NH Fuse - Metal	22
000	500	NHG000BI	gG/gL	NH Fuse - IMGL	22
000	500	NHM000B	aM	NH Fuse - Metal	42
000	690	EBH000	N/A	NH Fuse disconnecter - horizontal	62-65
000	690	NHG000B-690	gG/gL	NH Fuse - Metal	34
000	690	NHM000B-690	aM	NH Fuse - Metal	42
01	400	NHG01B-400	gG/gL	NH Fuse - Metal	16
01	400	NHG01BI-400	gG/gL	NH Fuse - IMGL	16
01	500	NHG01B	gG/gL	NH Fuse - Metal	25
01	500	NHG01BI	gG/gL	NH Fuse - IMGL	25
02	400	NHG02B-400	gG/gL	NH Fuse - Metal	17
02	400	NHG02BI-400	gG/gL	NH Fuse - IMGL	17
02	500	NHG02B	gG/gL	NH Fuse - Metal	27
02	500	NHG02BI	gG/gL	NH Fuse - IMGL	27
03	400	NHG03B-400	gG/gL	NH Fuse - Metal	18
03	400	NHG03BI-400	gG/gL	NH Fuse - IMGL	18
03	500	NHG03B	gG/gL	NH Fuse - Metal	29
03	500	NHG03BI	gG/gL	NH Fuse - IMGL	29
1	400	NHG1B-400	gG/gL	NH Fuse - Metal	16
1	400	NHG1BI-400	gG/gL	NH Fuse - IMGL	16
1	500	NHG1B	gG/gL	NH Fuse - Metal	26
1	500	NHG1BI	gG/gL	NH Fuse - IMGL	26
1	500	NHM1B	aM	NH Fuse - Metal	44
1	690	NHG1B-690	gG/gL	NH Fuse - Metal	36
1	690	NHM1B-690	aM	NH Fuse - Metal	44
1-pole	690	SD-D	N/A	NH Base	47-52
1-pole	690	SD-S	N/A	NH Base	47-52
2	400	NHG2B-400	gG/gL	NH Fuse - Metal	17
2	400	NHG2BI-400	gG/gL	NH Fuse - IMGL	17
2	500	NHG2B	gG/gL	NH Fuse - Metal	28
2	500	NHG2BI	gG/gL	NH Fuse - IMGL	28
2	500	NHM2B	aM	NH Fuse - Metal	45
2	690	NHG2B-690	gG/gL	NH Fuse - Metal	37
2	690	NHM2B-690	aM	NH Fuse - Metal	45
3	400	NHG3B-400	gG/gL	NH Fuse - Metal	18
3	400	NHG3BI-400	gG/gL	NH Fuse - IMGL	18
3	500	NHG3B	gG/gL	NH Fuse - Metal	30
3	500	NHM3B	aM	NH Fuse - Metal	46
3	690	NHG3B-690	gG/gL	NH Fuse - Metal	38
3	690	NHM3B-690	aM	NH Fuse - Metal	46
3-pole	690	TD-D	N/A	NH Base	47-52
4	500	NHG4G	gG/gL	NH Fuse - Metal	31
4	690	NHG4B-690	gG/gL	NH Fuse - Metal	39
N/A	250	170H0236	N/A	Microswitch	49
N/A	250	170H0238	N/A	Microswitch	49
N/A	250	BVL50	N/A	Microswitch	49
N/A	690	EBV	N/A	NH Fuse disconnecter - vertical	56-61
N/A	N/A	FEH	N/A	Fuse extraction handle	48
N/A	N/A	SDL	N/A	Solid link	48
N/A	N/A	SD-PB	N/A	Phase barrier kit	49
N/A	N/A	SD-SK	N/A	Shroud kit	48
N/A	N/A	TD-IP20	N/A	IP20 Protection kit	49

IMGL: Insulated Metal Gripping Lugs

Customer satisfaction team

Bussmann's Customer Satisfaction Team is available to answer questions regarding Bussmann products.

Europe calls can be made between:

Monday - Thursday 7.30 a.m. - 5.30 p.m. GMT

Friday 7.30 a.m. - 5.00 p.m. GMT

The Customer Service Satisfaction Team can be reached via:

Phone: 00 44 (0) 1509 882 600

Fax: 00 44 (0) 1509 882 786

Email: bulesales@eaton.com

'My Eaton' customer center

'My eaton' portal supports the following Divisions: B-Line, Bussmann, Crouse-Hinds, Cooper Lighting, Cooper Power Systems, Cooper Safety, and Cooper Wiring Devices.

Get started today at www.my.eaton.com by clicking 'Request User ID and Password'.

- Easy to Navigate
- Simple to Use
- Real-Time Data.

Online resources

Visit www.bussmann.com for the following resources:

- Product cross reference
- Product profiles
- Online catalogues for the latest United States and European catalogues.

Application engineering

Application Engineering assistance is available to all customers. The Application Engineering team is staffed by university-qualified electrical engineers who are available with technical and application support.

Europe calls can be made between:

Monday - Thursday 8.30 a.m. - 4.30 p.m. GMT

Friday 8.30 a.m. - 4.00 p.m. GMT

Application Engineering can be reached via:

Phone: 00 44 (0) 1509 882 699

Fax: 00 44 (0) 1509 882 794

Email: buletechnical@eaton.com

At Eaton, we're energized by the challenge of powering a world that demands more. With over 100 years experience in electrical power management, we have the expertise to see beyond today. From groundbreaking products to turnkey design and engineering services, critical industries around the globe count on Eaton.

We power businesses with reliable, efficient and safe electrical power management solutions. Combined with our personal service, support and bold thinking, we are answering tomorrow's needs today. Follow the charge with Eaton. Visit eaton.com/electrical.

Contact your local Eaton office

Electrical Sector
Eaton's Bussmann business
Melton Road
Burton-on-the-Wolds
LE12 5TH
Leicestershire
United Kingdom
bulesales@eaton.com
www.bussmann.com

Eaton Industries Manufacturing GmbH

Electrical Sector EMEA
Route de la Longeraie
71110 Morges, Switzerland
Eaton.eu

© 2014 Eaton
All Rights Reserved
Printed in the United Kingdom
Publication No. CA132004EN
November 2014

Changes to the products, to the information contained in this document, and to prices are reserved; so are errors and omissions. Only order confirmations and technical documentation by Eaton is binding. Photos and pictures also do not warrant a specific layout or functionality. Their use in whatever form is subject to prior approval by Eaton. The same applies to Trademarks (especially Eaton, Moeller, and Cutler-Hammer). The Terms and Conditions of Eaton apply, as referenced on Eaton Internet pages and Eaton order confirmations.

Eaton is a registered trademark.

All other trademarks are property of their respective owners.



Powering Business Worldwide