

Power Xpert® FMX metal-enclosed Single Busbar, Solid- and Air-insulated Switchgear
IEC Medium Voltage Switchgear up to 24 kV

FMX Smart, Innovative Design offers Economic and Reliable Solution



EATON

Powering Business Worldwide



Automotive



Aerospace



Truck



Hydraulics



Electrical

Powering business worldwide

Eaton delivers the power inside hundreds of products that are answering the demands of today's fast changing world.

We help our customers worldwide manage the power they need for buildings, aircraft, trucks, cars, machinery and entire businesses. And we do it in a way that consumes fewer resources.

Next generation transportation

Eaton is driving the development of new technologies – from hybrid drivetrains and emission control systems to advanced engine components – that reduce fuel consumption and emissions in trucks and cars.

Higher expectations

We continue to expand our aerospace solutions and services to meet the needs of new aviation platforms, including the high-flying light jet and very light jet markets.

Building on our strengths

Our hydraulics business combines localised service and support with an innovative portfolio of fluid power solutions to answer the needs of global infrastructure projects, including locks, canals and dams.

Powering Greener Buildings and Businesses

Eaton's Electrical Group is a leading provider of power quality, distribution and control solutions that increase energy efficiency and improve power quality, safety and reliability. Our solutions offer a growing portfolio of "green" products and services, such as energy audits and real-time energy consumption monitoring. Eaton's Uninterruptible Power Supplies (UPS), variable-speed drives and lighting controls help conserve energy and increase efficiency.



MV Switchgear Technology is in our DNA

Eaton's knowledge and understanding of industries, applications, technology and products enables us to offer customers safe, reliable and high performance solutions. We have been part of the Medium Voltage switchgear technology creation and therefore carry what's needed with us – always!

Complete MV switchgear solutions

The series of Eaton Medium Voltage systems offers switchgear and components for applications in distribution networks (main stations, substations and transformer stations) and industrial power supplies. These technically high quality systems are air- or epoxy-resin insulated and are always equipped with circuit-breakers based on proprietary vacuum interrupters.

The medium voltage switchgear systems carrying Eaton's brand are based on the use of vacuum circuit-breakers combined with solid insulation material. This is an environmentally-friendly technology in comparison with the methods used by many other suppliers, which use SF₆ as an insulation medium.

Eaton thus has a wide range of switching systems and components that offer an environmentally friendly solution for every application. Additionally, Eaton's global service network provides maximum customer support in all regions of the world.

Industry leading vacuum and solid insulation technology

Through more than eighty years of innovation and experience, Eaton has developed environmentally friendly vacuum interrupters capable of reliably switching both normal load currents and high stress fault currents.

Eaton is one of the few companies in the world producing vacuum interrupters and has succeeded in developing world class products with international patents. This has been achieved through company acquisitions over the years of Westinghouse, Cutler-Hammer, MEM and Holec.

To increase the dielectric strength of the vacuum interrupter, Eaton has also designed vacuum interrupters that are encapsulated in epoxy resin material. The medium voltage IEC circuit breaker family utilizes this solid insulation technology that has been catering to a wide range of applications for more than 40 years.

Eaton's range of
SF₆ free switchgear
for Medium Voltage



FMX Smart, Innovative Design offers Economic and Reliable Solution

Power Xpert® FMX is Eaton's IEC single busbar, solid- and air-insulated medium voltage switchgear system, for use up to 24 kV. The system provides reliable switching, protection, metering and distribution of electrical energy.

The modern design system uses Eaton's state of the art technology and is manufactured in accordance with the highest quality standards. Within the system our engineers have integrated Eaton core technologies, such as vacuum technology, solid insulation and electrical field control. More than a century of experience in design and production of medium voltage systems has gone into the product. Type FMX switchgear features a reliable and compact system design, which benefits from the best practices incorporated in Eaton's current range of MV systems. The system is tested according to the latest standard IEC 62271.

The system uses only environmentally friendly technology and materials. Since the type FMX system is based on vacuum technology and solid insulation, the system is the latest environmentally friendly "green" switchgear on the market.



The new system incorporates highly innovative technology, by implementing an electro-magnetic mechanism for the circuit-breaker control, and it introduces an integrated cable test facility outside of the high voltage compartment.

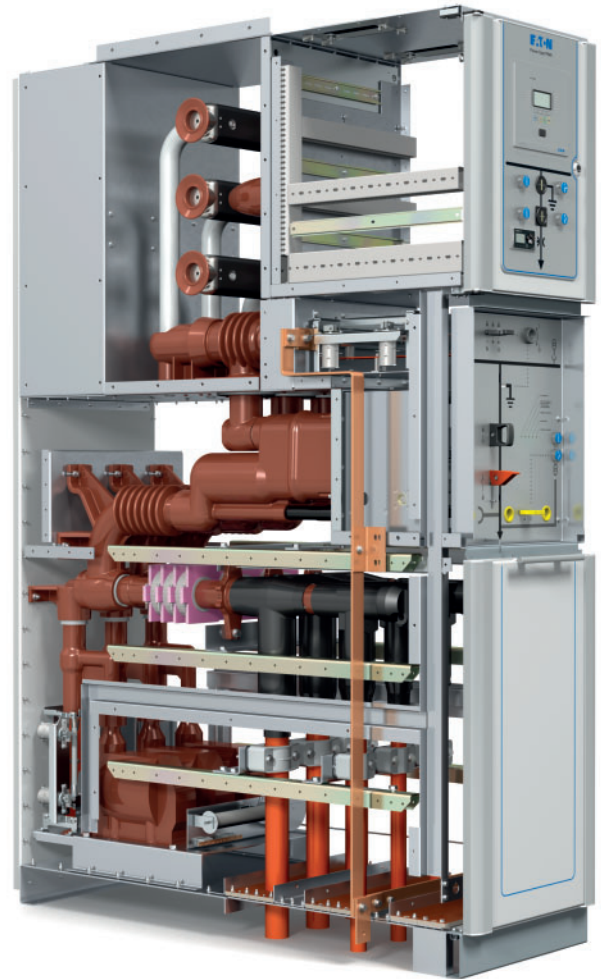

Complete Range up to 2000 A

The FMX comprises a complete range up to 2000 A, with metal-enclosed modular compact panels of a minimal 500 mm width. Both the 12 and 24 kV versions use the same compact housing.

FMX completes the range of Eaton medium voltage switchgear, being an extension to the successful products MMS (double busbar), Unitole (with-drawable switchgear), SVS (single busbar secondary switchgear) and Xiria (ring main unit).

In combination with Eaton's low voltage switchgear, busbar trunking, UPS products, project management and service capabilities, the FMX can be part of a state of the art, complete solution.

Application Areas

The FMX is ideally suited for applications in main feeder stations, sub-distribution stations and specific customer requirements in (process) industry, commercial and

governmental buildings and infrastructure projects. The design makes the FMX system especially suitable for applications where a reliable, safe, economic (e.g. compact) and clean (e.g. non-toxic) environment is necessary.

Some applications are:

- Utilities (main- and sub-distribution stations)
- Commercial and governmental buildings

- Infrastructure projects (tunnels, subways, airports, etc.)
- Hospitals
- Process industry
- Cement industry
- Mining industry
- Automotive industry
- Petrochemical plants
- Textile and paper industry
- Food industry
- Data centres

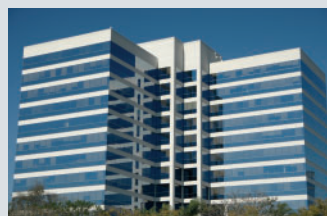

Features and Benefits

(quick overview)

Safe in Use

- Compartments protected against penetration by objects
- Capacitive voltage detection system for verification of safe isolation from supply
- Operation only possible with closed cable compartment
- Logical mechanical and electrical interlocks prevent mal-operation
- Cable testing via integrated cable test facility outside high voltage compartments
- Voltage transformers can be (dis)connected from the primary circuit, with closed high voltage compartments
- Smooth contemporary design

Low Total Cost of Ownership

Low initial costs due to:

- Panels minimum 500 mm width
- Cable connection from the front (back to wall arrangement)
- Integrated arc channel with absorbers
- 12 kV and 24 kV panels in the same housing

No costs during service due to:

- Robust design with a minimum number of parts (routine tested in factory)
- Long-life, using epoxy resin as insulation medium
- Maintenance-free circuit-breaker (electromagnetic mechanism and vacuum interrupters)
- No SF₆ pressure checks

Low end of life disposal cost due to:

- Vacuum switching technology
- Solid insulation with air as insulating medium
- Recycling or re-use of materials



User Friendly

- Cable connection and user interfaces for operation on the frontside of the unit
- Ergonomic cable connection height of 750 mm from floor level
- Different cable cone lengths for easy cable connection
- Cable (secondary) entry points on both sides of the low voltage compartment top plate
- Secondary cable terminals positioned at a good reachable height within the low voltage compartment
- Clear and simple, straightforward operation panels
- Facility for (dis)connecting the voltage transformers, easily accessible from the front without entering the HV compartment
- Integrated cable test facility positioned on the manual operation panel

Environmentally Friendly

- Minimised number of components
- Environmentally-friendly materials used in the design
- No use of SF₆-gas for switching and insulation (green switching)
- Energy-efficient production and assembly, with environmentally friendly energy sources
- Minimal number of transition points in the primary design enables low energy loss during operation
- Only re-usable and/or recyclable materials used

Reliable and Safe in Operation

- Complete design certified in accordance with IEC
- Arc fault tested in accordance with IEC 62271-200
- Quality assurance in accordance with DIN EN 9001
- Product quality guaranteed by execution of prescribed routine tests during production
- Single pole insulated primary parts within one compartment
- Separate busbar compartment
- Integrated cable test facility
- Ferro-resonance protected voltage transformers
- Integrated (internal) arc absorbers



Basic Design

The FMX system is modular in construction. This ensures that any panel combination and sequence is possible.

In addition, the number of panels capable of being used in an installation is unlimited, as several sections can easily be connected. The panels in the FMX system are compact (min. 500 mm wide), resulting in considerable savings in costs and installation space.

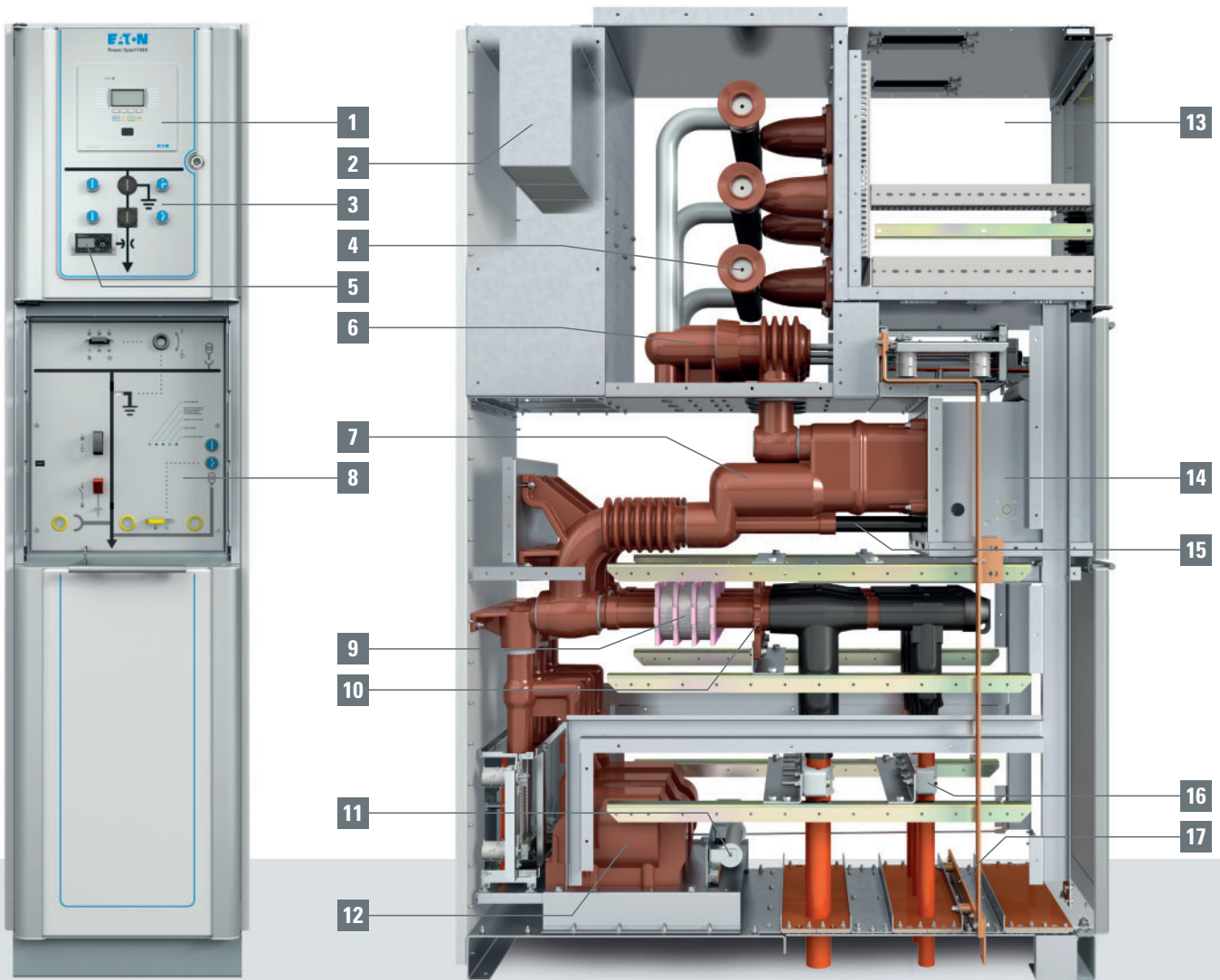

Circuit-breaker panel (example)

- | | | |
|---|--|---|
| 1. Protection relay | 7. Vacuum interrupter | 13. Low voltage compartment (electrical control panel) |
| 2. Arc absorber | 8. Manual operation panel with position indicator | 14. Vacuum circuit-breaker with electromagnetic mechanism |
| 3. Mimic diagram with push buttons for operation of circuit-breaker and two-position change-over switch | 9. Current transformers | 15. Cable test facility |
| 4. Busbar | 10. Cable cones | 16. Cable clamps |
| 5. Voltage detection system | 11. Coil and resistor for protection against ferro-resonance | 17. Earth bar |
| 6. Two-position change-over switch | 12. Voltage transformers | |

Main Components

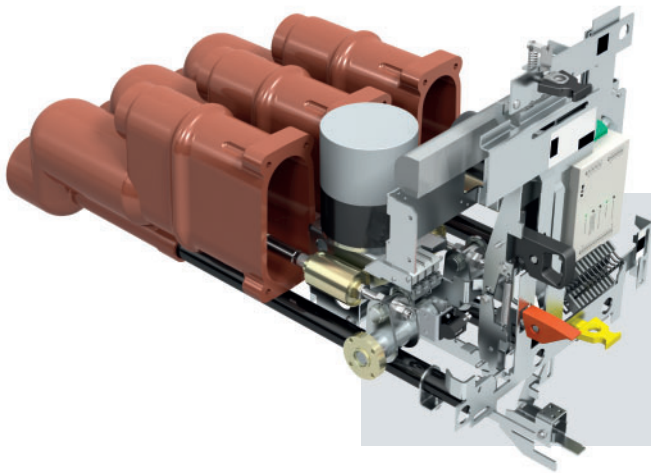

Vacuum circuit-breaker

The vacuum circuit-breaker uses a simple and reliable electromagnetic mechanism for operation of the vacuum interrupters. The construction of the mechanical linkage between the actuator and the drive rod of each of the three vacuum interrupters is reduced in complexity, compared to a conventional spring-charged mechanism.

Features

- Environmentally friendly vacuum interrupters
- Electromagnetic mechanism with controller
- Mechanical lever for hand-operated operation (switch off)
- Mechanical position indicator for Open / Closed position
- Auxiliary contacts for Open / Closed position

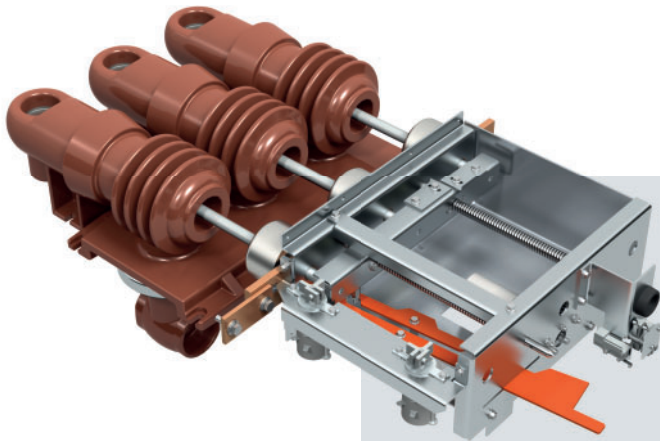

Two-position change-over switch

All panels are equipped with a change-over switch consisting of interconnected contact pins moving in the horizontal plane. Since it is mechanically interlocked, the change-over switch can only be operated when the circuit-breaker is in the open position.

Features

- Motor or manually-operated switch with two positions (Service / Earthed)
- Interconnected contact pins moving in the horizontal plane
- Contact pins epoxy resin insulated and located in the busbar compartment
- Auxiliary contacts for Service / Earthed positions
- Mechanical position indicators
- Interlocked with the vacuum circuit-breaker



Busbars

The busbars in the panel are constructed from high-quality aluminium bars of standardised cross-sections. The shape of the busbar has been designed to attain optimal electrical field control.

Features

- Busbars constructed from high-quality aluminium
- Branch of busbars made of copper or aluminium
- Aluminium parts are coated with galvanic silver layer
- Contact surfaces are treated with Penetrox
- Housed in busbar duct covering the full width of the panel
- Air insulated
- Situated in fully closed compartment complying with IP4X degree of protection

Eaton Core Technologies

Solid insulation using cast resin technology

Epoxy resin (cast resin) is used as high-quality primary solid insulation material around live parts.

By using cast resin technology for solid insulation, Eaton design engineers can shape the parts specifically for optimal insulation, robust construction and cooling purposes.

With many years of experience of design and manufacture of epoxy resin insulated components, we have learned to integrate conductors and vacuum interrupters directly into the moulding, and to make complex shapes. FMX utilises optimal field control through the special design of all primary components.

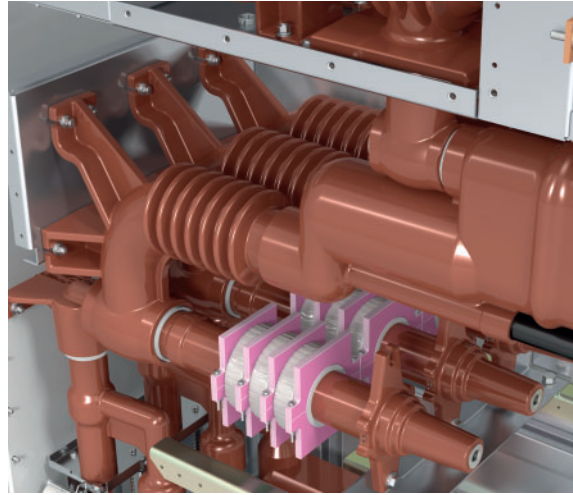

Electrical field control

With conventional shapes for primary components like busbars and conductors, the electrical field between the phases, and between phases and earth, is non-uniformly distributed. In areas with high fields, partial break-through can

trigger avalanches resulting in flash-overs. In-depth knowledge of breakthrough phenomena and field steering techniques enables us to prevent flash-over completely. The result is a particularly compact design.

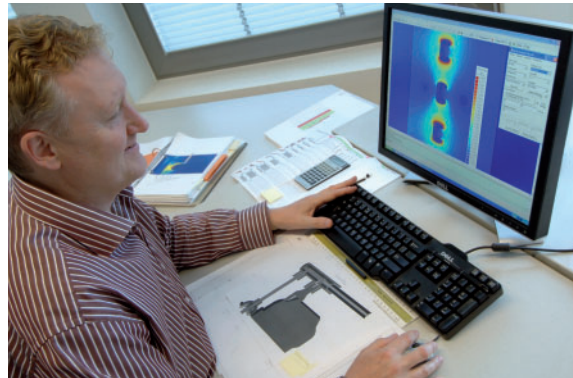

Vacuum technology: safe, compact and reliable

Eaton vacuum interrupters consist of a ceramic cylinder, housing a fixed and movable contact. Movement of the contact under vacuum conditions is performed by bellows. A shield surrounding the contacts prevents the insulators from becoming contaminated by metal vapour produced during current interruption. This shield also ensures good potential distribution over the insulator.

A special feature of Eaton vacuum interrupters is that a large number of parallel arcs are created between the contacts. This "diffuse discharge" is characterised by very low arc voltage and short

arc times, resulting in very low arc energy. Contact wear in a vacuum interrupter is therefore virtually negligible. Vacuum interrupters are maintenance free and are certified up to 30,000 operation cycles

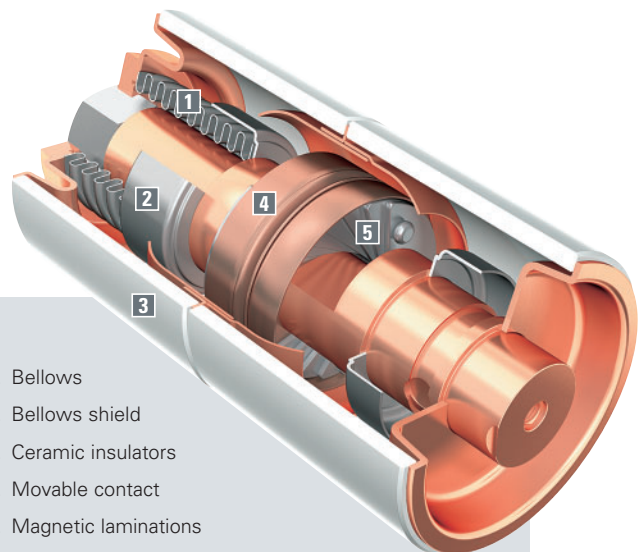
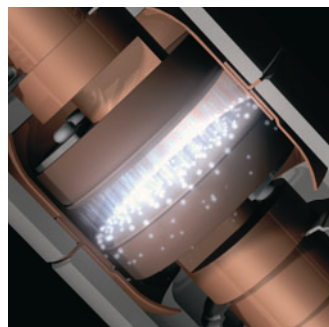

Innovative Electromagnetic Mechanism

The advantage of an electromagnetic mechanism over a conventional spring operated mechanism

To switch a vacuum interrupter effectively, the driving mechanism has to operate according to a specific force-stroke characteristic (→), see the diagram.

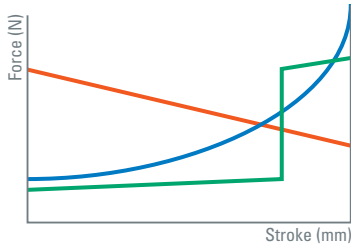
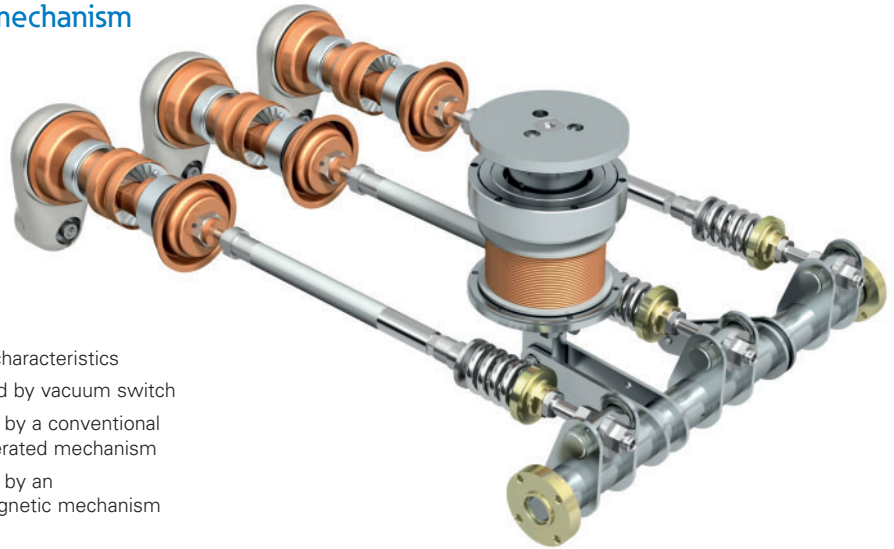

Force-stroke characteristics
 — as required by vacuum switch
 — as offered by a conventional spring operated mechanism
 — as offered by an electromagnetic mechanism

A conventional, spring operated mechanism has force-stroke characteristics (→) that differ greatly from the required characteristics. The required force-stroke diagram therefore has to be transferred from the spring characteristics, leading to mechanisms that require a large number of links moving at high speed.

An electromagnetic mechanism has a force-stroke diagram (→) that already resembles the force-stroke characteristic that is required for vacuum switchgear. Therefore electromagnetic mechanisms can be very simple in their construction. They consist of a minimum amount of parts and can be coupled directly to the

vacuum interrupter, because of the favorable force-stroke characteristics. Due to this direct coupling maximum rigidity is reached, which is advantageous for the rate at which contact pressure is reached and the effectiveness of contact breaking.

To summarise, the electromagnetic mechanism has the following advantages:

- Superior reliability due to use of less parts and direct drive with high rigidity
- Cost effective, maintenance free and compact due to the low number of parts
- Tested for a high number of 30,000 switching cycles

Innovative Electromagnetic Mechanism in FMX switchgear

Eaton's electromagnetic mechanism is based on the idea of separating the magnetic circuits for closing, holding and opening.

The mechanism consists of a permanent magnetic actuator and the basic mechanism in which a drive rod is connected to the vacuum interrupter. The permanent actuator is mono-stable; only the closed position is maintained by permanent magnets. The end position for opening, and therefore the stroke of the actuator, can be chosen at random within certain limits. For this innovative concept, a patent has been granted.

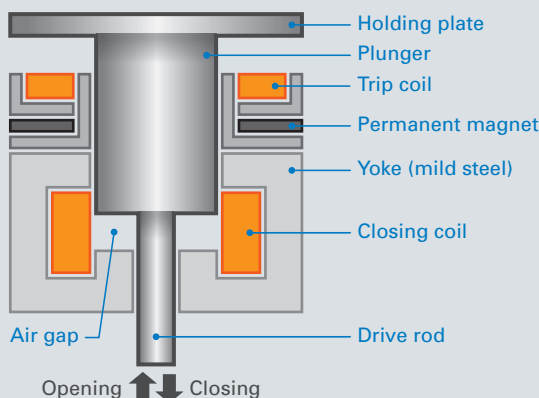

The standard position of the plunger is in the upper position. In this position the circuit-breaker is in the open position.

Closing

To close the circuit-breaker, the closing coil is energised. The current creates a magnetic flux in the yoke, which forces the plunger down. The force on the plunger is directly proportional to this current. When the force on the plunger becomes greater than the counteracting forces of the opening spring, the closing movement starts. When closed, the drive rod is kept in position by permanent magnets.

Opening / tripping

Opening is basically a passive action: the energy stored in the contact pressure spring and the opening spring is released. The release of this energy can be occasioned by an integrated trip coil, or a mechanical lever.

Tripping (opening) the circuit-breaker is done by energising the tripping coil. By this, the magnetic flux of the permanent magnet is partly compensated. As soon as the holding force of the permanent magnet is less than that of the contact pressure spring, the plunger will move to the upper position, consequently opening the contacts in the vacuum interrupters. Due to the force in the contact pressure spring, the required energy for tripping is very low compared to closing the breaker.

Reliable and Safe in Operation



Eaton's proven technologies have been integrated in the design and development of the FMX in order to ensure that the switchgear is safe and has high operational reliability throughout its complete lifetime.

Experience and knowledge gained over many years in the areas of cast resin technology, vacuum technology and electrical field control have been implemented.

The system has been thoroughly arc fault tested according to the latest standard IEC 62271-200.

Preventing an Internal Arc

Within the FMX design, different technologies are used to prevent an internal arc.

Use of electrical field control

Engineers designed the busbar compartment and its components (e.g. busbars, conductors) based on Eaton's key technology for electrical field control. By means of special shapes and dimensions, the possibility of an internal arc is minimised.

Protected voltage transformers

Ferro-resonance causes damage to voltage transformers and consequently initiates an internal arc in the switchgear. The design prevents the voltage transformers from being affected by ferro-resonance by installing a resistor and a coil in the tertiary circuit of the voltage transformer.

Separated busbar compartment

The FMX has a separate busbar compartment to prevent an internal arc. This compartment can be classified as non-accessible and has an IP rating of IP4X.

Coupling the busbar and constructing the compartment on site will be carried out by specially trained service personnel.

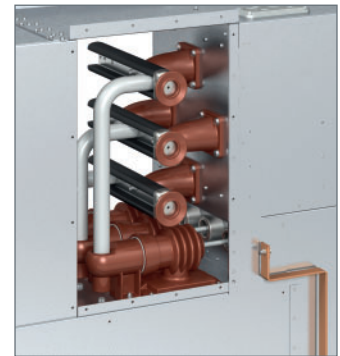

Single pole insulated primary parts

All high voltage parts in accessible compartments are single pole insulated. The insulation material used for this is epoxy resin (cast resin), a high-quality material with optimal insulation characteristic resulting in minimised dimensions.

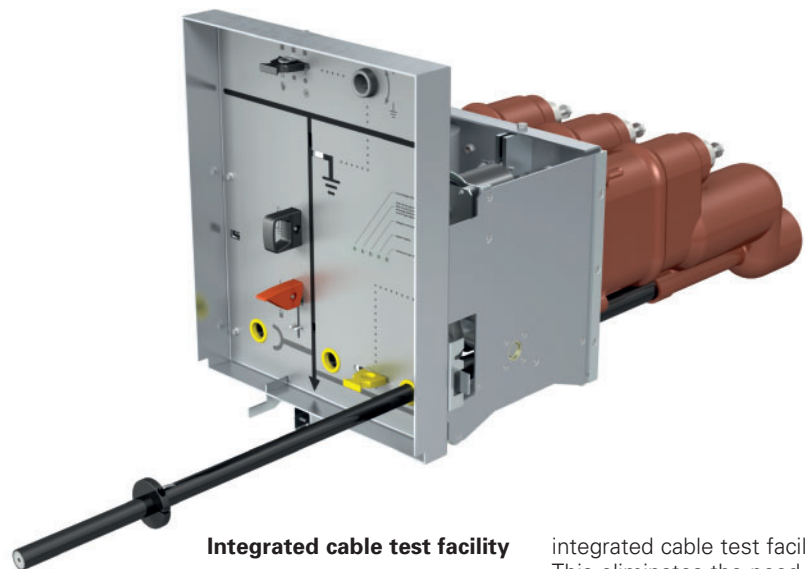

Integrated cable test facility

Internal arcs due to bad cable connections are becoming fewer, however they still occur. Therefore cables are tested before going live.

The FMX is equipped with an

integrated cable test facility. This eliminates the need to remove covers and disturb cable connections therefore reducing risk of incorrect re-installations of cable connectors or covers.

Routine tests

Various prescribed routine tests are carried out during the production of the switchgear. To assure quality, all processes are in accordance with DIN EN 9001. This means that at every stage of production the components, circuit-breakers and current transformers are inspected for correct functioning. When the entire installation has been

assembled, a thorough visual inspection is carried out, together with mechanical, functional and electrical checks.

Philosophy on Internal arcs

Eaton always puts extra focus on creating safe switchgear for operators at all times. One of the biggest potential threats to operators is an internal arc in switchgear.

Engineers therefore did everything necessary in design and construction to prevent internal arcs, despite the fact that it is very rare for an operator to be in front (without operating) of the switchgear at exactly the same time that an internal fault occurs.

Eaton supports the philosophy that it is best to avoid internal arcs than to cure, in line with the relevant standard

IEC 62271-200. Within the FMX design a double prevention philosophy is used. Firstly, the design is constructed in such a way that an internal arc is prevented. In the unlikely case that an internal arc could occur, the FMX is equipped to provide maximum safety to the operator, and to control and minimise damage to the rest of the switchgear and room.

Controlling an Internal Arc

An internal arc in switchgear causes an overpressure, together with the release of fire and smoke.

By design, vacuum and air/solid insulated switchgear has the least environmental impact after an internal arc event. The impact of an arc is twofold: internal impact (in the switchgear) and external impact (in the switch room).

The overpressure created by an internal arc will, in standard switchgear, be channeled out of the switchgear by means of a pressure relief duct. This duct is normally an additional compartment to the switchgear and therefore increasing the panel dimension. As an alternative to the duct, a

complicated and expensive arc channel can be installed, which guides the arc output into the switch room. The FMX is designed in such a way that both impacts are significantly reduced, and therefore in essence no complicated and costly arc channel is needed.

No phase-to-phase short circuits minimises pressure

Within the FMX, all high voltage parts in accessible compartments are single pole insulated. The advantage of this single pole construction is that the only conceivable internal

fault is a single-phase short circuit, e.g. due to a cable connection failure (when single-core cables are connected, as is normal practice nowadays).

Integrated compartments reduce pressure

By integrating different compartments, internal arc pressure is significantly reduced because of the volume.

For the FMX panel, cable connection, circuit-breaker and voltage transformers are integrated in one large, metal enclosed, compartment

instead of individual small compartments.

The busbar compartment of the switchgear consists of one overall compartment with no extra partitions between panels.



Arc absorber reduces output impact

To minimise the impact of an internal arc in the busbar compartment, the arc is "guided" outside the panel by an arc absorber installed in the rear of the unit. A standard

FMX feature is the use of an integrated arc absorber to reduce output into the switch room. By using ceramic blocks with an absorbing surface of 9 m² this absorber breaks up and filters gasses and fire significantly.



Safe in Use

Throughout the development of the switchgear, the safety of the operator during usage of the FMX was one of the most important criteria. Within the FMX, different features provide a safe situation for operators.

Compartments protected against penetration by objects

Within the FMX it is not possible to accidentally penetrate the switchgear with part of the body or a tool. For the latter, all high voltage compartments are rated to IP4X degree, and the low voltage compartment to IP3XD degree.

Capacitive voltage detection system for verification of safe isolation from supply

Each circuit-breaker panel within the FMX is equipped with a standard three-phase Voltage Detection System for voltage testing to IEC 61243-5. The VDS shows the operator if the panel is isolated from the supply or not.

Operation is only possible with closed cable compartment

The door of the cable compartment can only be opened when the circuit-breaker is in the earthed and padlocked position. This circuit-breaker position is maintained when the cable compartment door is removed. Also this position blocks the circuit-breaker mechanically, as well as electrically, from switching, therefore maintaining the safe earthed position whilst the door is removed. Operation of the circuit-breaker is only possible after installing the cable compartment door again.

Logical mechanical and electrical interlocks prevent incorrect operation

Mal-operation by an operator is prevented within the FMX using both mechanical and electrical interlocks. The interlocks are mechanical and electrical. For example, electrical and mechanical interlocks prevent operation of the change-over switch when the circuit-breaker is switched on. All mechanical interlocks are constructed in such a way that they directly block the mechanism.

Cable testing via integrated cable test facility (outside high voltage compartments)

Within the FMX, cable testing can be done outside dangerous high voltage compartments. Testing is done by inserting testing pins in specially designed holes in the manual operation panel. The holes are interlocked and therefore only accessible in a safe situation.

(Dis)connecting voltage transformers from the primary circuit, with closed high voltage compartments

For prevention of damage to the voltage transformers, they always have to be disconnected during cable or busbar testing. Within the FMX, (dis)connecting can be done very safely and easily via an operating mechanism situated on the manual operation panel. This ensures that operators do not have to access to dangerous high voltage compartments when (dis)connecting.

Smooth contemporary design

All compartments of the FMX are designed in such a way that the system is safe to touch from the outside. The use of a smooth and smart design prevents operators in the area of the switchgear to be injured, from moving parts or parts that stick out of the unit.



Low Total Cost of Ownership

The FMX design guarantees very low costs related to owning the switchgear during its entire lifetime.

The life-time costs can be split into initial costs, installation costs, service costs and finally, costs for disposal of the switchgear. All costs of ownership are influenced by different features of the switchgear. Within the FMX, all these features are constructed in such a way that the costs to the owner are as low as possible, of course with no concessions to the quality of the switchgear.

Low initial costs

Initial cost consist of purchase, transport, building and installation costs.

Panels of minimum 500 mm width

By using a combination of cast resin technology, electrical field control and vacuum technologies, Eaton's engineers managed to construct FMX panels with a width of minimum 500 mm. Because a typical switchgear installation normally consists of a large number of panels, this compact design significantly reduces the switch room size. The compact design also makes FMX highly flexible and economically attractive when existing installations are being replaced.

Cable connection from the front (back to wall arrangement)

Cable connection from the front is a feature that saves building costs. Due to this front connection the rear of the FMX can be installed close to the wall of a building, again reducing building cost.

Integrated arc channel with absorbers

Another standard feature that reduces the switch room is the integrated arc channel with absorber. In normal switchgear, gasses caused by an internal arc are guided out of the switchgear by means of an extra duct and arc channel connected to the switchgear. These additions require extra switch room space and consequently increasing initial building cost.

12 kV and 24 kV panels in the same housing

The 12 kV and 24 kV versions are both accommodated in the same compact housing. This means substantial savings on building costs, because the same installation can be used when the operating voltage is increased (upgrading).

Low service cost during operation

Service cost consist of maintenance, failure and consequential cost. Besides that the technical lifetime of parts or modules will determine the replacement cost of the equipment.

Robust "lean" design with the minimum number of parts

Costs during service of switchgear can be caused by damaged parts requiring replacement, or by maintenance cycles set up for critical parts that will not reach their expected lifetime if they are not serviced.

One of the design goals was to minimise the number of parts, to prevent the FMX getting damaged during the lifetime. The robust FMX construction, using only the necessary parts, is based on over a century's experience of designing and building switchgear.

Product quality guaranteed by prescribed routine testing in the factory

During production of the panels, various prescribed routine tests are carried out by specialists, making sure that the panels achieve the quality that they are designed for.

Epoxy resin insulated components as insulation medium

Practical research work on installed switchgear reveals that epoxy resin insulated components, as used within the FMX switchgear, show no signs of ageing.

Maintenance free vacuum circuit-breaker (electromagnetic mechanism and vacuum interrupter)

Spring-charged mechanisms always have a lot of moving parts that need lubricating to operate smoothly. Most of these mechanisms need a number of maintenance cycles during the lifetime of the switchgear. Within the FMX no spring-charged mechanism is used, but instead, a maintenance-free electromagnetic mechanism. This mechanism features a very simple design, with few moving parts, and needs no lubrication.

Because this mechanism can operate 30,000 switching cycles, there is in most applications, no extra investment necessary to upgrade the switchgear during its lifetime. In addition, the vacuum interrupters can easily achieve 30,000 operations.

No SF₆ pressure checks

Switchgear that uses SF₆ gas as an insulation medium has a leakage rate. To maintain the insulation level within this type of switchgear, the pressure of the SF₆ tanks must be checked and refilled on a regular basis during the unit's lifetime. With the FMX, an owner does not have to incur the extra costs involved in checking and maintaining the required insulation level. The combination of vacuum interrupters for switching,

cast resin technology and clean air as the insulation medium, is environmentally friendly and maintains the same quality level during the complete lifetime of FMX.

Low end of life disposal cost

Full recycling or re-use of materials

The primary parts of the FMX have a lifetime of at least 30 years. Depending on the location where the system is installed, this lifetime can be extended. If, for whatever reason, a decision is made not to use the switchgear anymore the FMX can be fully recycled.

Next the switchgear will be dismantled and the different materials can, and will, be categorised. Because no toxic materials are used in the FMX, dismantling is a less complicated, more cost effective and environmentally friendly operation. The dismantled and categorised materials will be, depending on the material, recycled or re-used.



User Friendly

First of all requirements is a safe and reliable installation. Number two is an installation that is convenient and efficient to operate.

The second aspect does not always get the attention it deserves, but for the FMX it most certainly did. The FMX panels are designed to be user friendly and are easy to operate.

Primarily, all operations can be carried out on the front side of the panel. This means that both cable connection and user interfaces for operation are positioned at the same front side of the panel. The logically arranged, user friendly electrical operation panel, and the user interface for manual operation, enable operators to do their job as efficiently and safe as possible.

Easy and ergonomic connection of cables

Primary cables

The cable cones of the FMX are positioned on a height of 750 mm from floor level. This height makes it relatively easy for operators to connect the primary cables. There is also enough space in the cable compartment to connect the required number of cables with connectors available on the market.

In case just one cable per phase is connected, the cable cones are positioned further to the front for easy assembly.

Secondary cables

Connecting the secondary cables is carried out by entering the low voltage compartment of the FMX from the top. The low voltage cable terminals are positioned in such a way that the operator can connect the cables easily within the compartment whilst standing in front of the FMX.

Clear and simple control panels

Incorporated in the FMX are two control panels with clear and uniform mimic diagrams.

The first (electronic) operation panel is located on the door of the low voltage compartment. This panel can, based on end-user request, have different set-ups. The end-user can choose to operate the switchgear electrically via:

- a control relay or
- close / open push buttons or
- selector switches.

The second (manual) operation panel is positioned behind the door of the mid section. As standard this panel has a facility for manually operating the change-over switch. This facility can be isolated by means of a padlockable selector switch. Standard on this panel is a control handle for manually switching the circuit-breaker off. The facility for padlocking in the earthed position is also a standard feature. For padlocking the different positions on the operation panels, the most common padlocks available on the market can be used.

Two options on this manual operation panel are the facilities for (dis)connecting the voltage transformers and testing the cables.

Simple and safe "Primary" (dis)connection of the voltage transformers

For (dis)connecting voltage transformers from the primary circuit, access to specific compartments is normally necessary. Within the FMX, (dis)connecting the voltage transformers can be done easily from the front of the switchgear without the need to access dangerous, high voltage compartments. The cable-side voltage transformers can be (dis)connected with a facility on the manual operation panel. The busbar-side voltage transformers can be (dis)connected by a safe and user-friendly facility positioned on top of the switchgear, and accessible from the front.

Easy and safe cable testing

A special feature is introduced for cable testing. The facility allows cable testing to be carried out very easily and safely, and without making any cable connection mistakes. The facility is positioned in the lower part of the manual operation panel and interlocked to prevent access.

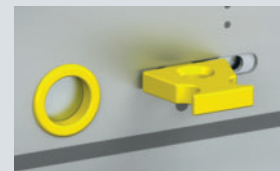

Environmentally friendly



Like all Eaton's other medium voltage switchgear, the FMX is designed to be an environmentally friendly product throughout the whole chain.

One of the key strategic initiatives of Eaton is to provide environmentally friendly products. Eaton realises that for this they should look at their total product chain, from design to dismantling. The optimal situation is that for each phase there is no damage to the environment and at the end, all materials can be re-used again in the same product (the Cradle-to-Cradle principle). The product chain can be divided into four main blocks. These blocks are the design (materials used) of the product, the assembly of the product, the usage phase of the product and finally the dismantling of the product.

Eaton's production plant in Hengelo (the Netherlands) acts entirely in accordance with the rules and procedures of the ISO 14001 environmental certificate during development and production processes.

Environmentally friendly design

With respect to the design of switchgear, the vision "the less number of components the better" applies. This because every part must be manufactured and therefore impacts on the environment. Next, applies the affect of different materials on the environment.

Use of minimised number of components

The FMX is designed to use the minimum of materials and resources, without affecting the strength of the system. For example, we have reduced the number of components dramatically, compared to conventional switchgear, by using an electromagnetic mechanism and integrated compartments.

Materials with no/less impact on the environment

Eaton selects materials with care. It is essential that they are safe for personnel and the environment - not just during use, but at the end of service life too.

Within the FMX a combination of solid (cast resin) insulation and air as insulation medium is used. The cast resin technology, in combination with electrical field calculations, provides a very compact, environmentally friendly design for the switchgear. As the

switching medium, vacuum technology is used within the interrupters of the FMX circuit-breakers. FMX can be completely recycled at the end of its life without any problem.

No use of SF₆ gas for insulation or switching

Within medium voltage switchgear SF₆ gas is used, because of its good insulating properties. Emissions of SF₆ gas from switchgear contribute significantly to the threat of the greenhouse effect and associated climate change. SF₆ is on the list of greenhouse gasses in the Kyoto protocol.

SF₆ is the most potent of the six main greenhouse gasses, with a Global Warming Potential (GWP) of 23,000.

In the 1980s, the Holec group, as it was then, made a fundamental choice not to use SF₆ as a switching and insulation medium for medium voltage equipment. In the 1980s, Holec had SF₆ technology available in-house. The main reason for not using any SF₆ in medium voltage equipment was the complexity of the treatment required for the toxicity of the gasses that have been in contact with an arc, and the need for additional safety measures when used in public locations such as residential areas and shopping centres.

Efficient use of materials

Besides the energy sources, special focus was placed on the efficient use of material during assembly. For example, sheet steel plates are cut with as little waste material as possible. Residual material is used within other product components.

Minimal energy loss during operation

To prevent energy loss by the system itself, the FMX uses a minimum number of primary change-over points. All the available change-over points use optimal surface contacts and by this, prevent extra energy losses over these points.

No service checks on site

Because the FMX is designed for a lifetime of at least 30 years, the system needs no energy usage for maintenance activities during this long period. Due to the green insulation and switching technology, there is also no leakage of the SF₆-gas during its lifetime and no need for extra maintenance activities on SF₆ pressure checks.

Re-use or recycling of materials

During dismantling the FMX is demounted into parts and thereafter categorized per material. Next the parts will be recycled or re-used. Because the FMX uses no SF₆, there is no loss of this gas during dismantling of the switchgear.



Exactly how you want it

Flexible application of secondary apparatus, protection relays and substation automation

Every application of this type of system is unique, so Eaton offers a large number of different panel types and field versions. If, in due course, the end-user needs additional capacity in the form of more panels, FMX can easily be extended to the right or left. Eaton realises that end-users have their own wishes and routines with respect to the use of secondary apparatus, protection relays and substation automation within the switchgear. The need for customer specific apparatus and relays was taken into account during the development of the FMX. This resulted in a system that enables end-users to integrate

apparatus according to their specification. Thanks to the large number of protection and control options, end-users will always be able to construct an FMX system that conforms exactly to your requirements.

Range of Voltage transformers

All FMX panels can be fitted with cast-resin insulated voltage transformers (of the requested transformer ratio and class) for the voltage measurement on the cable side, or on the busbar side. Both transformers can be (dis-)connected safely and easily.

Range of Current transformers

The epoxy resin insulated current transformers are of the ring core type. They are positioned around the primary conductors behind the cable cones. All common transformer ratios, outputs, rated currents and classes are possible.

Protection and Control equipment

The protection and control equipment is located in the low voltage compartment. This compartment is completely separate and has its own access door. There is space on the door for a mimic diagram and equipment such as

protection relays, voltage detection systems, meters, etc.

The FMX is standardised for the SEG HighProtec relays series. However the FMX is adaptable for the installation of other brands.

In case more than one relay is required, the low voltage compartment can be extended.

Smart Grids

Equipment for (remote) communication between panels or automation systems can also be installed in the low voltage compartment. Having this possibility makes the system the perfect solution for current and future Smart Grid applications.

Fixed in Philosophy, Flexible in Design

The FMX switchgear is designed based on Eaton's proven fixed technology. The primary objective of this technology is to increase safety and reliability within a more compact and cost effective housing.

The advantages of a fixed design...

The fixed design contains different features that provide optimal reliability of the switchgear.

Firm connections between breaker and the overall system

Firm and simple interconnection between the breaker and the other fixed system parts (cable and busbar) ensure a robust and reliable system.

Optimal safety by fixed interlocked housing

Optimal safety is realized by integrating all primary parts into a fixed housing. Access to high voltage compartments in the switchgear are prevented by safety interlocks. Within these compartments all primary parts are sealed for live by means of epoxy resin. Operation of the switchgear is very simple and only possible when the high voltage compartments are closed. The operation panels are positioned at the front side of the switchgear and the safety interlocks provide a safe situation for the operator.

Reliable circuit-breaker

The latest design in electromagnetic mechanism is used to control the circuit-breaker. This electromagnetic mechanism and the vacuum interrupters it operates, are both tested for 30.000 full-load operations and 100 short-circuit operations. This number of operations in combination with the simple mechanism design, requires no maintenance and exchange activities on the circuit-breaker. Moreover this maintenance-free fixed design responds to the current lack of technically skilled personnel that will become even worse in future.

Additional flexibility ... control and exchange of circuit-breakers

Despite the fact that the fixed FMX design has all the features that contribute to optimal reliability, some customers still want to have the ability to test, maintain and/or exchange the circuit-breaker very simple and quickly. To meet this market demand the FMX added this flexibility to its fixed design.

Controller for status indication of the mechanism

First of all the FMX is equipped with a "health check" function for testing the quality of the circuit-breaker. By means of a controller the quality of the circuit-breaker mechanism is being checked. The controller is

for example checking the opening and closing circuit. The status will be presented on the manual operation panel or remote.

Easy and quick exchange of the circuit-breaker

The FMX circuit-breaker can be exchanged in less than 30 minutes. Only a few steps are necessary to remove the circuit-breaker. By use of a simple tool the breaker will be moved from a horizontal to a vertical position. This procedure requires a minimal working space in front of the panel. Plugging-in a new breaker can be done in the opposite sequence with minimal effort.

Because the system is based on fixed technology the primary contacts are very simple and robust. The latter will provide that during exchange the contacts will not be damaged. During exchange of the breaker the rest of the switchgear can stay energized and therefore minimising the impact on the grid. For optimal operator safety we have executed internal arc tests in the busbar compartment and the adjacent panels while the breaker was withdrawn.

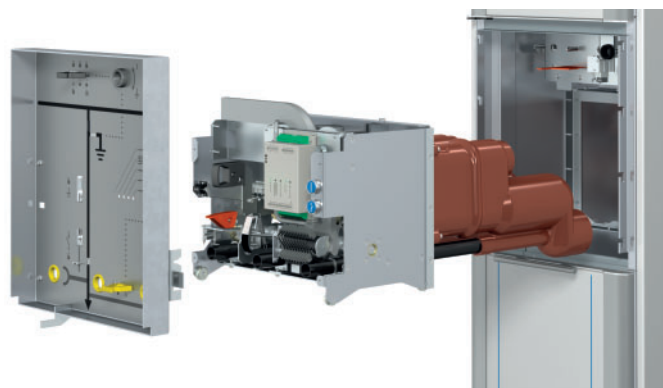

Product Range

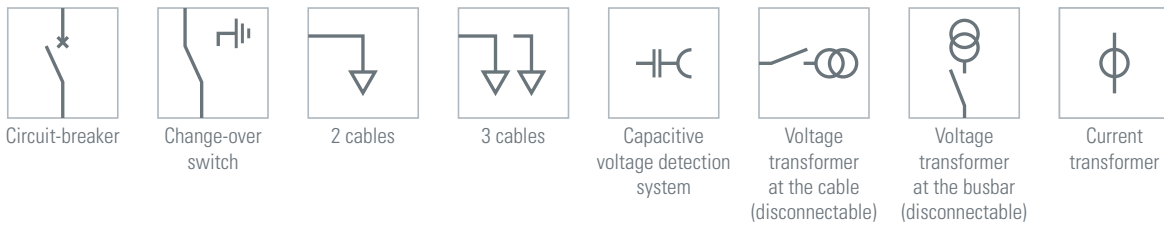
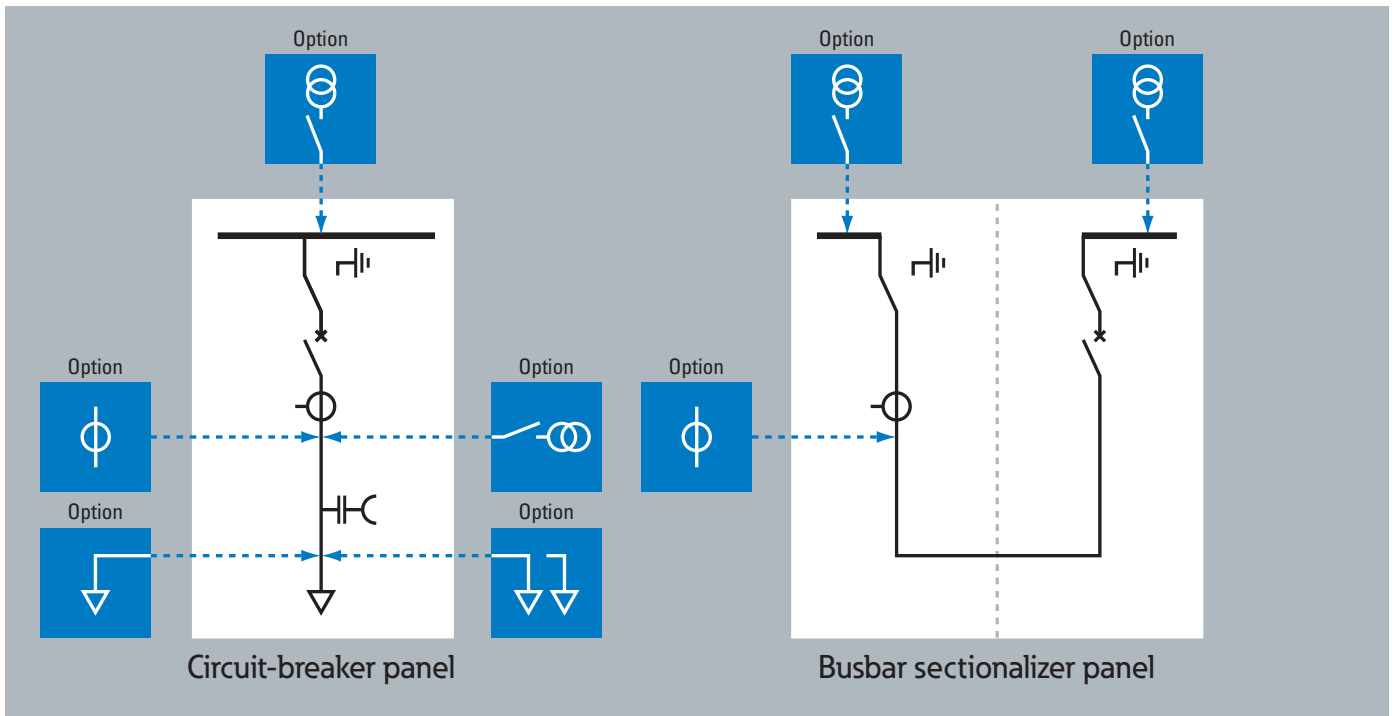

Dimensions (mm)

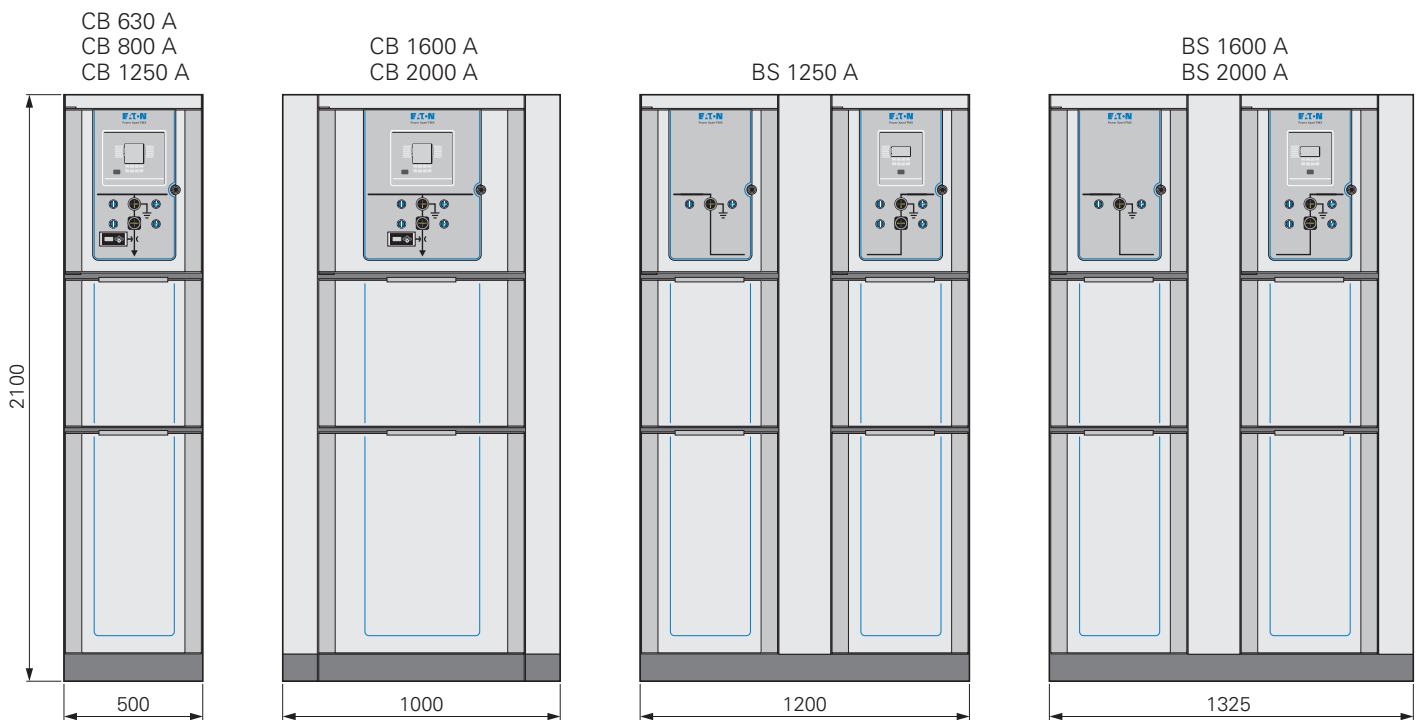

Depth: 1450 mm

Extra panel height: 500 mm for busbar side voltage transformers, 150 mm for busbar venting box, 500 mm for busbar side cooling box on 2000 A panels.

Electrical Data

FMX switchgear system		12 kV	17.5 kV	24 kV
Rated Voltage	kV	12	17.5	24
Lightning Impulse withstand voltage	kV	75	95	125
Power frequency withstand voltage	kV	28	38	50
Rated frequency	Hz	50	50	50
Internal arc class		AFL 25 kA - 1 s	AFL 25 kA - 1 s	AFL 25 kA - 1 s
Loss of service continuity category		LSC2B	LSC2B	LSC2B
Partition class		PM	PM	PM
Earthing circuit	kA - s	25 - 3	25 - 3	25 - 3
Compartment circuit-breaker/cable		Interlock-controlled	Interlock-controlled	Interlock-controlled
Compartment busbar		Tool-based / non-accessible	Tool-based / non-accessible	Tool-based / non-accessible
Degree of protection HV compartments (optional)		IP4X	IP4X	IP4X
Degree of protection LV compartment		IP3XD	IP3XD	IP3XD
Temperature classification		Minus 5 °C indoor	Minus 5 °C indoor	Minus 5 °C indoor
Busbar system				
Rated normal current	A	2000	2000	2000
Rated short-time withstand current	kA - s	25 - 3	25 - 3	25 - 3
Rated peak withstand current	kA	63	63	63
Circuit-breaker - incoming feeder and sectionalizer				
Rated normal current	A	1250 - 1600 - 2000	1250 - 1600 - 2000	1250 - 1600 - 2000
Rated short-circuit breaking current	kA	25	25	25
Rated short-circuit making current	kA	63	63	63
Rated short-time withstand current	kA - s	25 - 3	25 - 3	25 - 3
Circuit-breaker - outgoing feeder				
Rated normal current	A	630 - 800	630 - 800	630 - 800
Rated short-circuit breaking current	kA	25	25	25
Rated short-circuit making current	kA	63	63	63
Rated short-time withstand current	kA - s	25 - 3	25 - 3	25 - 3
Class		E2, C2	E2, C2	E2, C2
Operating cycles at short-circuit current		100	100	100
Single capacitor bank switching	A	400	400	400
Mechanism				
Rated operating sequence	A	O-0.3 s-CO-15 s-CO	O-0.3 s-CO-15 s-CO	O-0.3 s-CO-15 s-CO
Class		M2	M2	M2
Opening time	ms	50	50	50
DC component	%	35	35	35
Closing time	ms	70	70	70
Number of operations actuator		30,000	30,000	30,000
Number of operations interrupter		30,000	30,000	30,000
Auxiliary voltage	V	24, 48, 60, 110, 220 V _{DC} 110/230 V _{AC}	24, 48, 60, 110, 220 V _{DC} 110/230 V _{AC}	24, 48, 60, 110, 220 V _{DC} 110/230 V _{AC}
Mechanism change-over switch				
Opening time	s	< 20	< 20	< 20
Closing time	s	< 20	< 20	< 20
Number of operations change-over switch		1,000	1,000	1,000
Class		M0	M0	M0

Standards

FMX complies with the following international standards

IEC 62271-1	Common specifications
IEC 62271-100	Circuit-breakers (E2, M2, C2)
IEC 62271-102	Disconnectors and earthing switches (E2, M0)
IEC 62271-200	Metal enclosed switchgear and controlgear
IEC 60044-1	Current transformers
IEC 60044-2	Voltage transformers
IEC 60529	Degrees of protection (IP Code)
IEC 61850	Communication networks and systems in substations
IEC 61243-5	Live working - Voltage detectors - Part 5: Voltage detecting systems

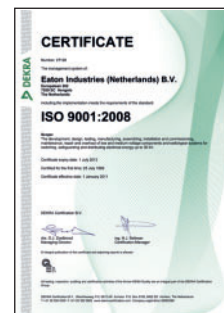

EAT•N

The power of fusion.

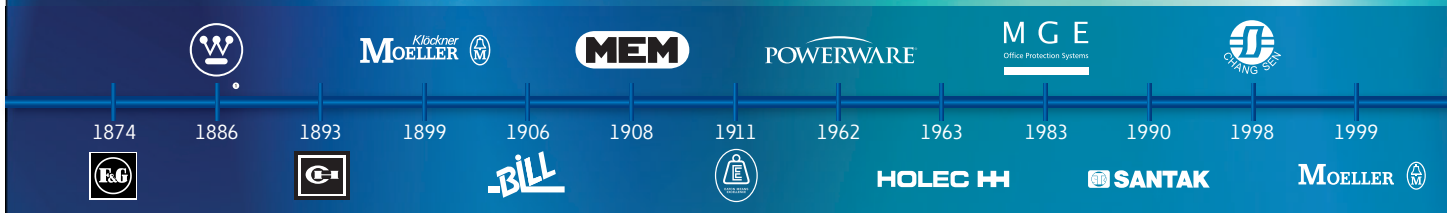

EAT•N

Powering Business Worldwide

There's a certain energy at Eaton. It's the power of uniting some of the world's most respected names to build a brand you can trust to meet every power management need. The energy created supports our commitment to powering business worldwide.

From power distribution to power quality and control, Eaton allows you to proactively manage your complete power system by providing electrical solutions that make your applications safer, more reliable, and highly efficient. Visit www.eaton.com/electrical.

All of the above are trademarks of Eaton Corporation or its affiliates. *Eaton has a license to use the Westinghouse brand name in Asia Pacific. ©2009 Eaton Corporation.

Eaton's Electrical Sector is a global leader in power distribution, power quality, control and automation, and monitoring products. When combined with Eaton's full-scale engineering services, these products provide customer-driven PowerChain™ solutions to serve the power system needs of the data center, industrial, institutional, public sector, utility, commercial, residential, IT, mission critical, alternative energy and OEM markets worldwide.

PowerChain™ solutions help enterprises achieve sustainable and competitive advantages through proactive management of the power system as a strategic, integrated asset throughout its life cycle, resulting in enhanced safety, greater reliability and energy efficiency. For more information, visit www.eaton.com/electrical.

Eaton medium voltage products in the energy chain

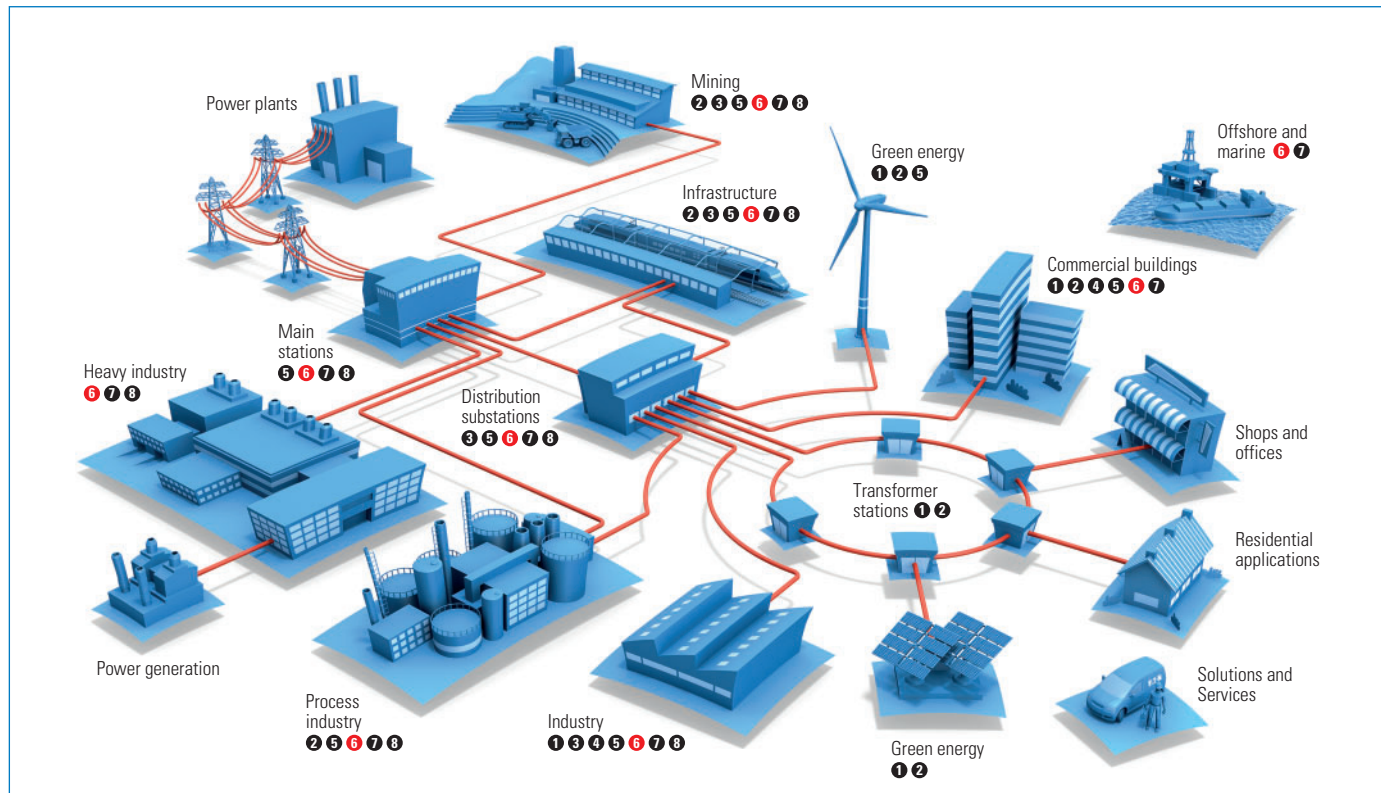

1 Magnefix



2 Xiria (blocktype)



3 Xiria E (extendable)



4 Xiria M (metering solutions)



5 SVS



6 Power Xpert® FMX



7 Power Xpert® UX



8 MMS

Eaton Industries (Netherlands) B.V.
P.O. Box 23
7550 AA Hengelo
The Netherlands

Tel.: +31 (0)74 - 246 40 10
Fax: +31 (0)74 - 246 40 25
info.electric@eaton.com
www.eatonelectric.com
www.eaton.eu/fmx

© 2012 Eaton Corporation
All rights reserved.

Form No. 6054012BR04
September 2012

The information provided in this document reflects the general characteristics of the referenced products at the time of issue and may not reflect their future characteristics. Eaton Corporation reserves the right to modify the contents of this document and the characteristics of the referenced products without prior notification. Eaton Corporation does not assume liability for potential errors or omission of information in this document.