

Eaton – convincing in terms of safety, performance and operational availability.

IEC/EN 61439



Technical Guide – xEnergy Switchboard systems

EATON

Powering Business Worldwide



xEnergy: Controls systematically. Saves in three ways. Thinks ahead.

With Eaton, you have a business partner who supports your expertise in every respect. With Eaton xEnergy, you have a switchboard system that provides you with a wide variety of options for reliable power distribution and individual solutions to meet your customers' needs.

The xEnergy system range thinks ahead. This means it is designed to meet constantly increasing requirements. Geared towards a maximum of efficiency in implementing your individual projects, Eaton xEnergy provides optimum conditions for building-infrastructure up to 5000 A.

Every single function module in this switchgear assembly is perfectly prepared and syste-

matically planned – from the switchgear and fitting system technology to enclosures and software tools.

Systematic switching = Shaping the future

You too should opt for this technically sophisticated and cost-effective unit of switchgear and protective devices, fitting systems and switchboard systems. It helps you to optimally switch and control power, in

other words to dominate it. The system is module-based and offers smart combination options.

And there is a wide range of benefits for you. They do not only include the optimal added value in your own panel building business and the certainty that – with Eaton – you will always be building state-of-the-art and safety-tested panels. They will also help you to save time, money and space.



IZM

The variable circuit breaker up to 6300 A

Its module width will increase depending on the rated current, while height and depth of the switchgear will remain the same. Increased operational availability thanks to its robustness and the ability to communicate, cost-optimized planning thanks to modular design, suitable for worldwide use, with xEnergy and xVTL.



NZM

The compact circuit breaker up to 1600 A

Available in four breaking capacity levels, compact and space-saving, suitable as a main circuit breaker for machinery controlgear, incoming supply switches in installation distribution boards or outgoing switches in power distribution boards, for xEnergy and xVTL, for worldwide use.



SASY 60i

Modular busbar system

For effective power distribution in the switchboard cabinet. In combination with the latest motor protectors and circuit breakers, it forms a consistent solution for switching, controlling and distributing power. UL-certified.



PIFT

Plug In Fuse Terminal

Revolutionizes the fuse-related technology in distribution board building. With its wide range of different types, its modular setup and its uncomplicated options for expansion and conversion, it offers the required flexibility. It is convincing thanks to the extremely high level of short-circuit strength of up to 120 kA with AC500V, optional fuse monitoring and an integrated switch-on lock.

5 variants, with maXimum benefits.



XP Power Sections

- Incoming supplies, outgoing and couplings with circuit breakers
- Internal separation up to form 4
- Cable connection from the top or bottom
- Incoming supply system for drill-free cable connection



XF Fixed

- Power outgoing with circuit breakers and fuse switch disconnectors up to 630 A
- Internal separation up to form 4
- Individual outgoing, such as controlgear, motor starters, small power outgoing etc.



XG General

- Power factor corrections
- Fitting systems for sub-distribution with devices for modular installation
- Control technology with SASY 60i and xStart
- Individual fixed units on a mounting plate



XR Removable

- Power outgoing with circuit breakers and strip type switch-disconnector-fuse, up to 630 A
- Empty modules for individual applications
- Plug-in modules and strip type switch-disconnector-fuse can be replaced under live-line working conditions
- Internal separation up to form 4
- Easy maintenance and reduced down times



XW Withdrawable

- Power outgoing with circuit breakers up to 630 A
- Outgoing for motor starters up to 250 KW
- Empty drawers for individual applications
- Easy and uniform handling for all drawer sizes
- Drawers can be replaced under live-line working conditions
- Internal separation up to form 4
- Unambiguous position indicator for operating, test or de-energized status
- Easy maintenance without the need of using any special tools for replacement jobs
- Minimum down times

IEC/EN 61439

Eaton implements the new series of standards for low-voltage switchgear assemblies as early as NOW – and makes it significantly easier for panel builders to do their job.

To ensure the safety of low-voltage switchgear assemblies, many and the most varied characteristics of the individual components need to be harmonized and defined in a generally applicable standard.

So far the IEC/EN60439 series of standards covered this requirement. As of 2014, it will be replaced by a new standard. But Eaton builds its switchgear in line with the new standard as of now.

Innovations at a glance

The new standard makes a difference between the manufacturers – as usually practiced – between the original manufacturers on the one hand and the panel builders on the other hand. These two parties involved in building a switchboard system have to separately provide evidence of conformity to show that the part each one is responsible for meets the requirements of the standard.

This actually means that the panel builder now has to pay a lot more attention to providing the evidence of conformity for his part of the technical execution.

- The distinction between “type-tested assembly TTA” and “partially type-tested assembly PTTA” no longer exists in the new standard.
- Evidence of conformity with the standard is provided through design verifications, they include tests, calculations and the verification of whether the design rules have been respected – i.e. that from now on the systems will be design-verified. Panel builders who already build TTAs now do not have to expect many changes.
- The panel builder can depending on the type of system – choose between three different ways of providing evidence of conformity:
Verification by testing,
Verification by design rules or
Verification by calculation.
All of them are equally valid, as defined by the standard.

- The term “TTA Switchgear assembly and controlgear assembly according to IEC/EN 60439-1” will be replaced by:
“Power switchgear and controlgear assembly according to IEC/EN 61439-2, design verification by testing”

- If the panel builder carries out changes in the original system of a switchgear and controlgear assembly that are not covered in the design verification, these changes must be specified in a separate design-verification document.

- The new standard also includes requirements of the standard for empty enclosures, such as resistance to corrosion, resistance to heat of enclosure parts made of insulating material and protection against mechanical impacts.

xEnergy, in conformity with the standard

As an original manufacturer, we will continue to provide evidence of conformity for the system in the future as well. In order to make it easier for the panel builder to provide evidence of conformity for his part of the responsibility, a large number of applications have been split up into standardized modules and the design verification by testing has been carried out for them to provide the evidence of conformity. These modules, assembled in accordance with the corresponding instructions, will enable you to carry out your projects in a cost-effective way and in compliance with the requirements of the standard.

Service / Support / Software

Eaton actively supports the "Services in Automation" initiative of ZVEI (Association of the German electrical and electronics industry). For the services we offer, this means: The services are tailored to the customer's needs, they are easy to identify, they guarantee that the competences required for the services offered are available and that the results and performance data are defined together with the customer.

Service



Design-verified quality

Eaton is DIN ISO 9001 certified. The quality of Eaton products is reliable. For switchboard systems, Eaton trusts in a modular design principle consisting of accurately fitting function modules, design-verified in accordance with the IEC/EN 61439 standard. The system modules can be arranged to comply with specific national requirements such as DIN VDE, CEI, NF or UNE.

So Eaton offers all relevant protective switchgear assemblies in the respective degree of protection up to 5000 A. In addition, design verification of the entire unit of switchgear, fitting system technology and cabinet in accordance with IEC/EN 61439 provides for a high level of safety.

This modular system allows for easy expansion to meet increasing future requirements.

Delivery according to customer's needs

Eaton offers the entire product range in flat-packed versions, functionally packed as assembly groups, or as cabinets pre-assembled to customer specifications. Short delivery times make it easy to react to enquiries or modifications requested by the customer.

- Easy configuration and ordering thanks to tools that support the setup of parts lists
- Fast delivery ex warehouse thanks to lean logistic processes
- Easy handling of individual parts thanks to convenient packaging units
- Safe and time-saving assembly based on Eaton assembly instructions

The system offer is optimized for the incorporation of internationally available Eaton switchgear and protective devices and it is completed by configuration and planning tools.

The right tool for every project stage and safe power distribution!



Technical support



Eaton's technical support is both competent and reliable. New customers are offered optional training on how to build a design-verified switchgear assembly.

The advantage of realizing the first switchgear assembly directly with the panel builder is an opportunity to communicate the optimal workflow.

Field Service:
+49 228602 3640

Product Support:
SupportDistributionboard
Austria@eaton.com

Website:
www.moeller.net/xEnergy

Software



Eaton provides you with the appropriate tools. Software tools for planning, documentation and calculation not only support planning engineers, but also panel builders or installers. Eaton's toolbox is perfectly designed for network and system planning right through to ordering. Using Eaton's tools including the system-specific data ensures a safer, faster and more efficient way of processing orders.

CurveSelect

The program for characteristic curves of protective devices is available free of charge and allows the user to display setup-specific tripping curves of several protective devices simultaneously – both in terms of time and electric current values. The tool makes it easy for the user to analyze the interaction of NZM and IZM circuit breakers, PKZ motor-protective circuit breakers, ZB overload relays and circuit breakers as well as h.b.c. fuses.

Freely defined curves (FreeStyleCurves = FSC) enable the user to directly compare the

- selected motor protector and motor starter characteristics,
- incoming supply switches and up-stream medium-voltage protection
- intended expansions and existing protective equipment.

CurveSelect supports you in planning and documenting your system.

xSpider

A graphic-oriented draft system for dimensioning low-voltage networks equipped with Eaton protective switchgear. xSpider is available for free download. The software includes a database with all protective switchgear (MCBs, MCCBs, ACBs, fuses, motor starters). MatSelect is a database for the management of product and material data in both user-defined and standardized classification systems.

Configurator for xEnergy

For a quick and easy configuration of the xEnergy switchgear assembly you want. Sets up an offer in no time and generates the parts list at the push of a button.

MatSelect MatSelect database

With MatSelect, you can manage all your product and material data in user-defined and standard classification systems.

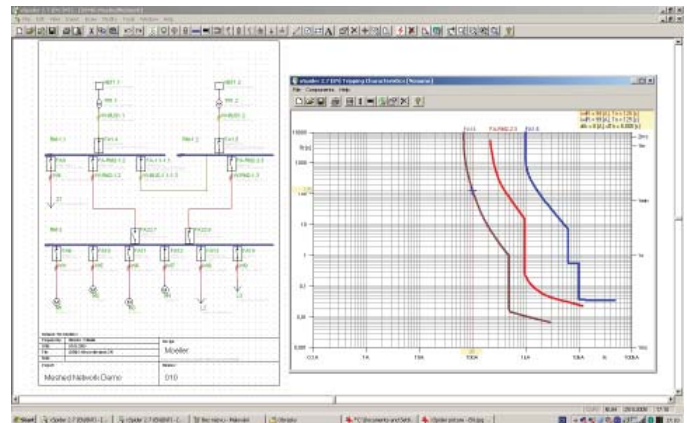

xSpider

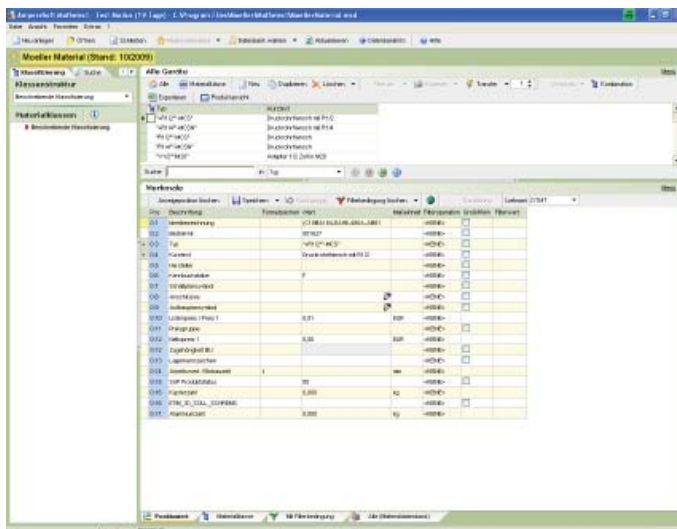

MatSelect Database

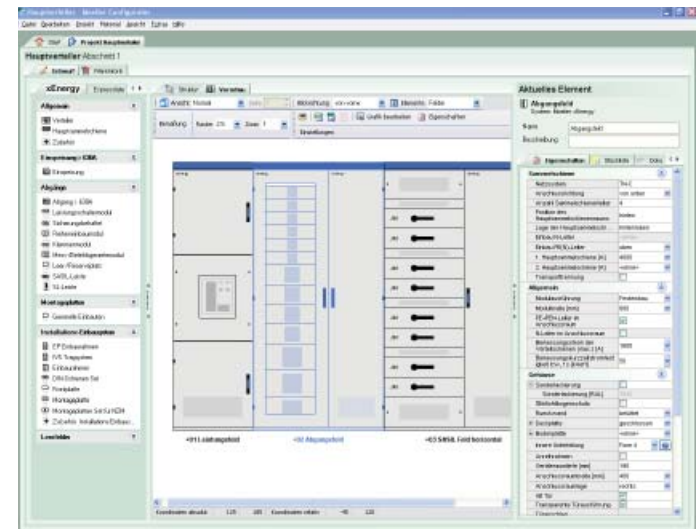

Configurator for xEnergy

Safe yesterday. Standard today.
Pioneer in protective technologies of tomorrow.

Eaton's early-warning systems: More safety for your switchboard.

Machines and systems simply have to work. No matter whether it is in industrial or functional buildings – unscheduled standstills are always costly and annoying. The best thing to avoid undesirable down-times is to take appropriate precautions.

For reliable operation

Trust in proven technologies! A design-verified switchgear assembly ensures safe power

distribution and a smooth workflow.

For the protection of people and systems

Wherever power is involved, safety is paramount. Eaton has always been a pioneer in the protection of people and systems. Apart from our proven protective switchgear, there are additional innovations to still increase the high level of safety for staff while operating a system. Be it in the power supply for tunnels, paper mills or data centers – uninterrupted power supply through ARCON® is key for the protection of people and machinery.

This is because an arc-fault will be extinguished by Eaton's arc-fault protection system before it can deploy its destructive impact on the power supply system. Eaton provides additional safety through internal compartment separation up to Form 4 and passive arc-fault protection. The result: Systems that ensure a maximum of operational availability and security and a minimum of down-times.

Power management for the future

Power is precious. It should be used in a resource-efficient and careful way. The new metering and communication modules

are a valuable contribution to a responsible way of using energy resources.

Proven components in this field:

- xEnergy removable and xEnergy withdrawable technology
- IZM Open-type circuit breakers
- NZM Compact circuit breakers
- ARCON® arc-fault protection system

Contents

xEnergy - Product philosophy

Introduction	Page 2
Technical data	Page 6
Sample text for tenders	Page 7
System description	Page 8

Room and space requirements

XP Power sections, power distribution boards up to 5000A	Page 9
XF Outgoing sections - fixed design	Page 15
XR Outgoing sections - removable design	Page 30
XW Outgoing sections - withdrawable design	Page 40
XG Empty sections - for general equipment	Page 44

Planning notes

Eaton Engineering Tools	Page 46
Setup instructions	Page 47
Passive arc-fault protection	Page 49
Dimensions	Page 50

xEnergy power distribution

System description



xEnergy product features

- Enclosures for side-by-side and stand-alone cabinets
- Degree of protection IP31 or IP55
- Main busbars up to 5000 A
- 2 Main busbar systems are possible in each section
- Clear separations into functional areas from form 1 to form 4 to provide even better protection for people and equipment
- Widths of 425, 600, 800, 850, 1000, 1100, 1200 and 1350 mm
- Height 2000 mm
- Color RAL 7035 (other colors upon request)
- Network types TN-C, TN-C-S, TN-S, TT, IT
- Type-tested switchgear assemblies in accordance with IEC/EN 61439
- Optimized for 3 and 4 pole switchgear from Eaton

XP - Power sections

Incoming supplies, outgoing and couplings up to 5000 A

- cable connection from the top and bottom
- busbar positions rear-mounted - bottom/top mounted or running under the top panel
- section height 2000 mm / section depth 400/600/800/1000 (1000 = 800+200) mm
- internal separations up to Form 4



Air circuit breakers IZM 20 up to 63

- widths of 425/600/800/1000/1100/1200/1350 mm
- fixed or withdrawable
- 3 or 4 poles
- with a second busbar suitable as a coupling section
- 630 - 5000 A
- Form 4
- IP31, IP55 with IZM-XDT protective cover
- suitable for drill-free cable connection, can be installed at the top or bottom
- to be operated from outside
- suitable for switchgear with remote operation

Compact circuit breakers NZM3/4 in Form 4

- widths of 425/600/800 mm
- fixed or withdrawable
- 3 or 4 poles
- with a second busbar suitable as a coupling section
- 250 - 630 A (NZM3)
- 630 - 1600 A (NZM4)
- Form 4
- IP31/55
- suitable for drill-free cable connection, can be installed at the top or bottom
- to be operated from outside
- installation of two switching devices in one section is possible
- suitable for switchgear with remote operation



Compact circuit breakers NZM4 in Form 2

- widths of 425/600/800 mm
- fixed or withdrawable
- 3 or 4 poles
- with a second busbar suitable as a coupling section
- 630 - 1600 A
- Form 2
- IP31/55
- suitable for drill-free cable connection, can be installed at the top or bottom
- to be operated behind the door as high as the section
- suitable for switchgear with remote operation

XF - Outgoing sections - Fixed design

- Outgoers with circuit breakers PKZ, NZM, FAZ, switch fuse units and fuse switch disconnectors up to 630 A
- for busbar positions at the rear - top/bottom or running under the top panel
- section height 2000 mm / section depth 600/800 mm



Outgoing sections for outgoers up to 630 A in Form 2

- widths of 800/1000/1200 mm
- module widths of 425 and 600 mm
- 3 or 4 poles
- Form 2
- IP31/55
- consistent mounting height of switchgear
- circuit breakers suitable for use with plug base
- single-wing section door up to 800/1000 mm, 2-wing door for 1200 mm
- suitable for switchgear with remote operation
- operation behind the door
- dropper bar to be selected from 800-1600 A
- separate set-up in 2 separate sections is possible, e.g. 600 mm/600 mm. Switchgear area/ cable connection area



Outgoing sections for fixed outgoers up to 630 A in Form 4

- widths of 800/1000/1200 mm
- module widths of 425 and 600 mm
- each module comes with its own front panel
- 3 or 4 poles
- Form 4
- IP31/55
- circuit breakers suitable for use with plug base - NZM3 with plug base ... in 800 mm deep sections
- suitable for switchgear with remote operation
- separate doors to switchgear area and connection area
- transparent doors (glass doors) are possible
- dropper bar to be selected from 800-1600 A
- separate set-up in 2 separate sections is possible, e.g. 600 mm/600 mm. Switchgear area/cable connection area



Outgoing sections for fuse strips up to 630 A (SL)

- widths of 600/800/1000 mm
- vertical position of fuse strips
- IP31/ IP55 with door in section height
- outgoers are possible downwards and upwards
- Form 2
- operation from outside or behind the door



Outgoing section for fuse strips up to 630A with section dropper bar up to 1600-3200 A (SL-I) across two sections

- widths of 600/800/1000 mm
- dropper bar to be selected from 1600-3200 A
- Form 2
- fuse strips in vertical position
- IP31/ IP55 with door as high as the section
- outgoers are possible downwards and upwards
- up to 40% Cu savings
- operation from outside or behind the door
- quick and easy mounting of fuse strips thanks to the double-bar system



Box solution

- widths of 600/1000/1200 mm
- module widths of 425/600 mm
- each module comes with its own door to the switchgear area
- 3 or 4 poles
- fixed or withdrawable
- suitable for switchgear with remote operation
- to be operated behind the door or with rotary door coupling handle
- dropper bar to be selected from 800-1600 A
- empty and module panels for the set-up of outgoers (RCD, FAZ ...)
- Form 4
- IP31/55

XR - Outgoing sections - Removable design



Outgoing sections for switch fuse units (load disconnecter units) up to 630 A (SSL)

- widths of 600/800/1000/1200 mm
- suitable for rear-mounted main busbar HSS
- horizontal and vertical position of fuse switch disconnecter strips is possible
- can be installed while energized (fuse strips)
- IP31
- outgoers are possible downwards and upwards
- Form 4
- operation from outside
- dropper bar selectable from 800-1600 A



Plug-in module technology - outgoing sections in Form 2

- widths of 800/1000/1200 mm
- module width 600 mm
- Form 2
- 3 or 4 poles
- IP31/55
- consistently equal mounting height of the switchgear
- single-wing section door with 800/1000 mm, double-wing door with 1200 mm
- suitable for switchgear with remote operation
- to be operated behind the door
- empty plug-in module for the incorporation of RCD, FAZ ...
- dropper bar selectable from 800-1600 A
- separate set-up in 2 separate sections is possible, e.g. 600 mm/600 mm. Switchgear area/cable connection area



Plug-in module technology - outgoing sections in Form 4

- widths of 800/1000/1200 mm
- module width 600 mm
- Form 4
- 3 or 4 poles
- IP31/55
- each module comes with its own front panel
- separate doors to switchgear area and connection area
- transparent doors (glass doors) are possible
- empty plug-in module for the incorporation of RCD, FAZ ...
- to be operated behind the door
- dropper bar to be selected from 800-1600 A
- separate set-up in 2 separate sections is possible, e.g. 600 mm/600 mm. Switchgear area/cable connection area

XW - Outgoing sections - Withdrawable design



Outgoing sections - withdrawable design

- widths of 1000/1200 mm
- section depths of 600/800/1000 mm
- 3 or 4 poles
- rated current of dropper bars $I_n=1000$ or 2000 A / 3 or 4 poles
- max. short-circuit current $ICW=80$ kA
- IP31/55
- shelf-boards can be mounted at individual heights, depending on the size of the modules
- max. height of dropper bar available to accommodate equipment = 1875 mm
- cable connection area, fully sealed off from the switchgear area, main busbar area and dropper bar area
- dropper bar at the front fully sealed off thanks to self-closing shutters
- drawers available:
 - power outgoers up to 630 A
 - direct starters from 0.06-132 kW
 - reverse starters from 0.06-132 kW
 - star-triangle starters from 5.5-110 kW
- outgoers from 132 to 250 kW are executed as fixed design solutions

XG - Empty sections for General equipment



Empty sections for individual mounting units

- fitting systems for modular installation devices (IVS, EP, Profi+ ...)
- individual mounting units fixed on mounting plates
- control technology - suitable for installation of mounting plates as high as the section, or of split ones
- section height 2000 mm
- section depths of 400/600/800 mm
- section widths of 425/600/800/850/1000/1100/1200/1350 mm
- IP31/55

Technical Data

		Rear busbars up to 5000 A Top busbars up to 3200 A
Standards/regulations		IEC/EN 60439-1, IEC/EN 61439-2
Ambient temperature	°C	-5 up to +40, +35 (24h average value)
Relative humidity	%	50 at 40°C
Protective measure		Protection class I, protective conductor connection
Degree of protection ¹⁾		IP31, IP55 according to IEC/EN 60529 IK10
Rated insulation voltage U_i	V	1000
Rated voltage U_e	V	690
Insulation coordination		III/3
Insulation voltage U_{imp}	kV	8
Overvoltage category		IV
Degree of pollution		3
Rated frequency	Hz	40-60
Busbar rated current I_e	A	up to 5000
Busbar rated short-time withstand current I_{DW}	kA	up to 100 (1s)
Busbar rated peak withstand current I_{pk}	kA	up to 220
Sheet thickness	mm	Door and frame = 2, rear, side and top panels = 1.5
Metal surfaces		Electro-galvanized, powder-coated
Color		RAL 7035 light-grey
Lock mechanism		Espagnolette lock with 2 or 4 point locking and turn-lock 3 mm two-way key bit
On-site installation conditions		Indoor installation according to IEC/EN 60439
Dimensions	mm	Width: 425 – 1350 Height: 2000 (optional 100 or 200 mm with plinth) Depth: 400, 600, 800, 1000

¹⁾ The degree of protection of the fitted components - depending on the specifications given in the components catalogue - must be taken into account.

Tender text



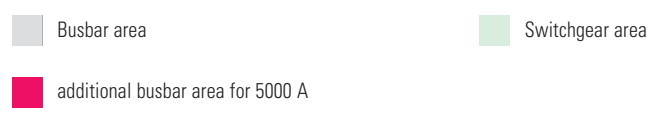
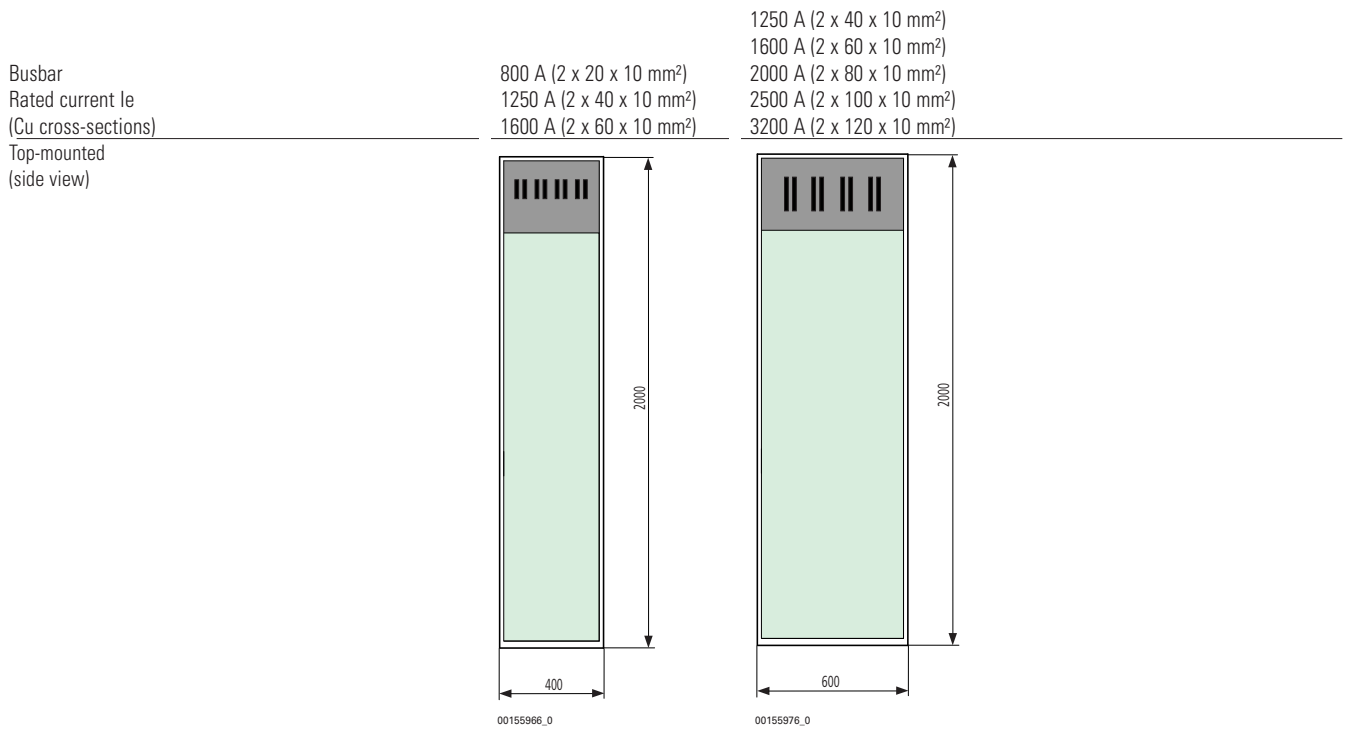
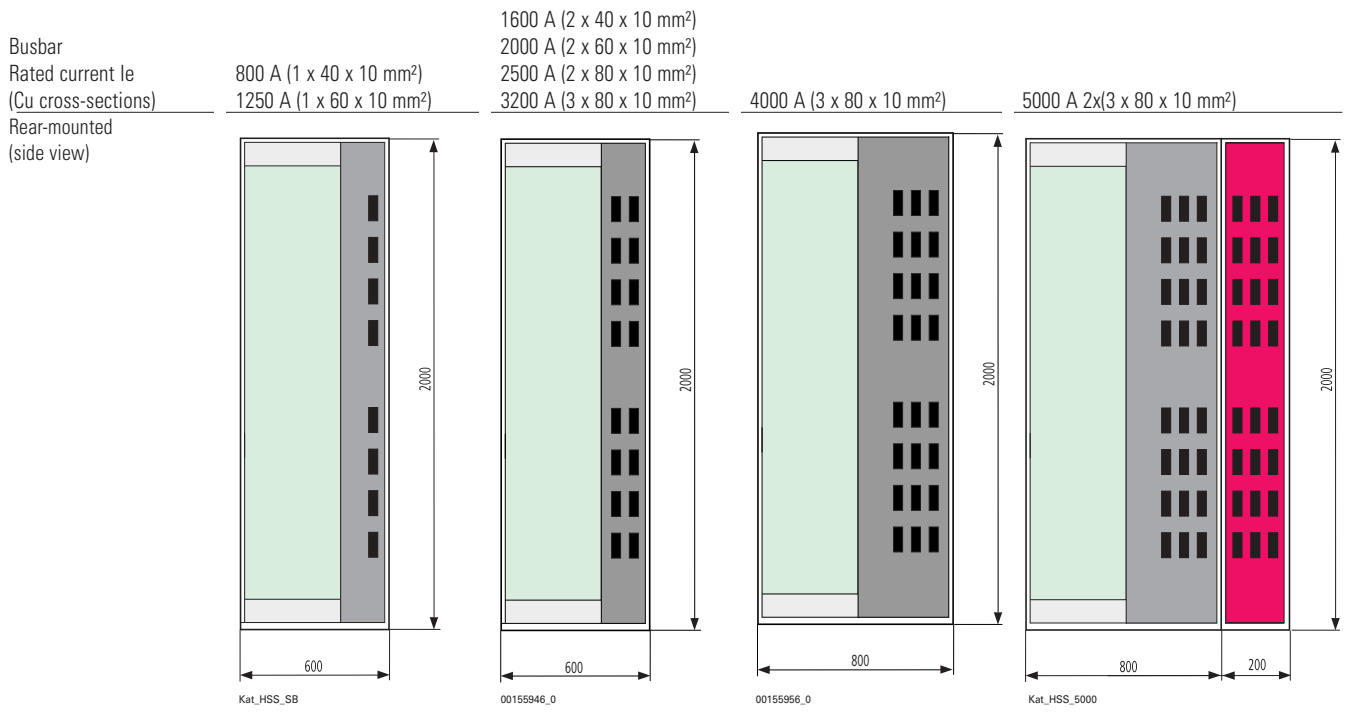

- Ready to connect, steel-encapsulated low-voltage switchgear system in multiple control panel design with type-tested installation systems to IEC/EN 61439-1 (VDE 0660 part 500), IEC/EN 61439-2 (VDE 0660 part 600-2).
- The following descriptions are calculation-related and contractual elements. They are to be considered with the descriptions of the individual systems and the equipment, even when they are not mentioned in detail.
- Cabinet systems consisting of individual add-on sections of the same type in torsion-resistant steel profile design, made of electrolytically galvanized 2 mm thick steel sections, with internal pre-drilled holes at 25 mm intervals to DIN 43660, structured powder spray paint RAL 7035 light grey.
- Removable external panelling, made of 1.5 mm electrolytically galvanized sheet steel, structured powder spray paint RAL 7035 light grey.
- All construction parts for internal setup are hot-galvanized and feature pre-drilled holes at 25 mm intervals to DIN 43660.
- Plinth 100/200 mm high, electrolytically galvanized, powder-coated in RAL 7035 light grey, with removable front, side and rear panels. The plinth must be suitable for direct transport with the respective tools.
- Switchboard cabinets accessible from the front through inlying doors with external hinges. 180° door opening angle. Door lock with espagnolette lock, 4 point locking and two-way key bit lock. To be actuated with a clip-down handle for half cylinder safety lock.
- Degree of protection: IP31 to DIN EN 60529
IP55 with sealed door
- Protective measures: with protective conductor, protection class I
- Rated insulation voltage: 690 V
- Overvoltage category: III
- Degree of pollution: 3
- Rated operational voltage: V
- Frequency: Hz
- Control voltage AC/DC: V
- Busbar rated current: A
- Rated short-time withstand current I_{cw} kA/s
- Network system configuration
- Busbars (number), conductor labelling
- Max. dimensions allowed
Width
Height
Depth
- Largest transport unit allowed
Width
Height
Depth
- All transport units feature removable lifting eyebolts.
- Equipment of the switchgear system with the following components, fixed installation method:
.....
.....
.....
.....
- Fully assembled switchgear system described above, ready to connect and prewired, subject to 100% ex-factory test to IEC/EN 61439 part 1. The test protocol is part of the documentation.
- Manufactured by Eaton
- Type xEnergy

System description - main busbars and section depths

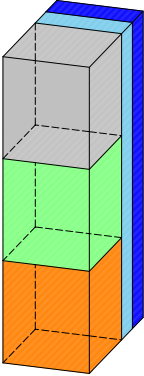
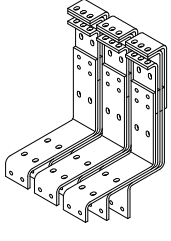
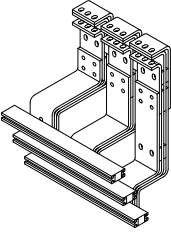
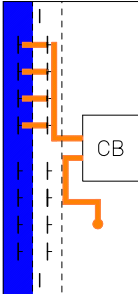
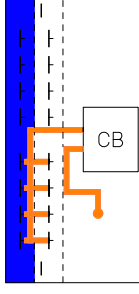

xEnergy Technical Guide

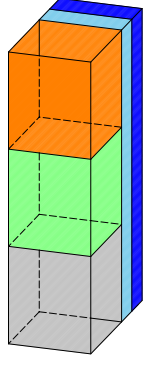
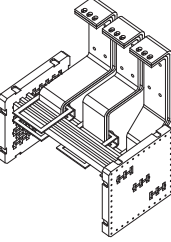
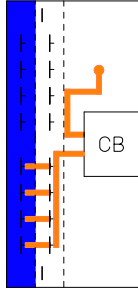
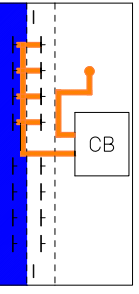
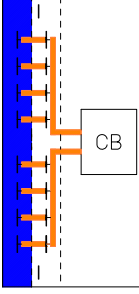
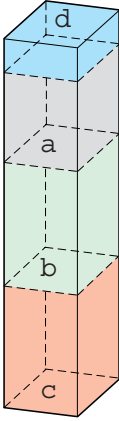
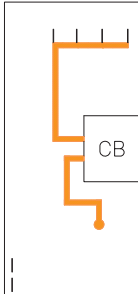
XP Power sections for circuit breakers up to 5000 A

	Functional areas	Connection area	Busbar systems	Switchgear area 2
Busbar at the rear		 	 	
		 <p>Central incoming supply up to 4000 A: Cable connection system: drill-free connection across the entire section width, contacting from the front by means of connection terminals (brace terminals)</p>	  	
Busbar at the top				

Switchgear area 1

Switchgear area 2

Connection area

Busbars

Additional busbar area where 5000A are used

XP Power sections for circuit breakers up to 1600 A

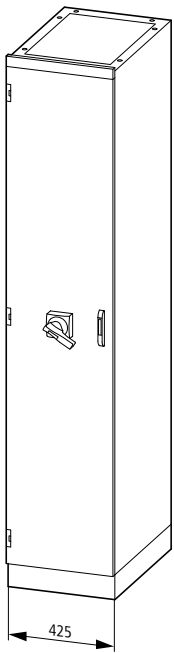

00160782_0

425
(600, 800)

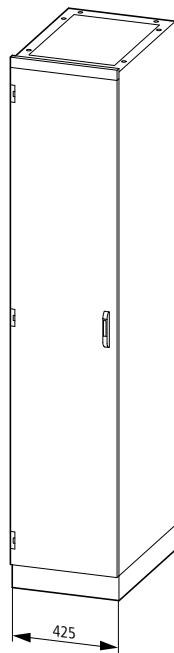

00160792_0

425
(600, 800)

Section widths of 425 mm, 600 mm and 800 mm, internal separation up to Form 4.

With 4-pole breakers, the width of distribution sections will increase to 600 mm.

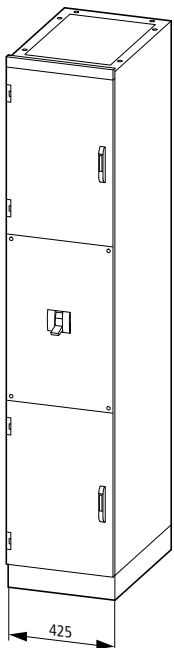

00160764_0

425
(600, 800)

For compact circuit breakers NZM3/4:

- in withdrawable or fixed design
- in 3-pole or 4-pole version
- as incoming, outgoing or coupling switchgear or - with the busbar at the top - as an outgoing or incoming switchgear only
- for measuring purposes you can mount current transformers between the connection and the switchgear
- 2 devices possible in 1 section in Form 4
- connection directly to cable connection flags, tunnel-type terminals, drill-free cable connection system

Dimensions

- Section widths of 425, 600 or 800 mm
- Section height 2000 mm, optional with plinth of 100 or 200 mm
- Section depth 600 or 800 mm; section depth 800 mm only with rear-mounted busbar

Connection area

- to cover up the connection copper you will need the connection area cover XKSA
- connection directly to a flag connector or to tunnel-type terminals

With internal separation of Form 1 up to Form 2:

- with a front door as high as the cabinet
- doors ventilated, closed or transparent
- with doors right or left-hinged
- operation of the switch behind the door or with an extension shaft and the rotary door coupling handle from outside

With internal separation up to Form 4:

- 2 switchgear area doors, one above and one below the device, as well as a cover strip with quick-acting closures in the centre in front of the device
- switchgear to be operated from outside
- doors ventilated or closed
- with doors right or left-hinged
- areas not used for cable connection may be used for accommodating additional equipment, e.g. controlgear or surge protection devices

XP Power sections for circuit breakers up to 5000 A

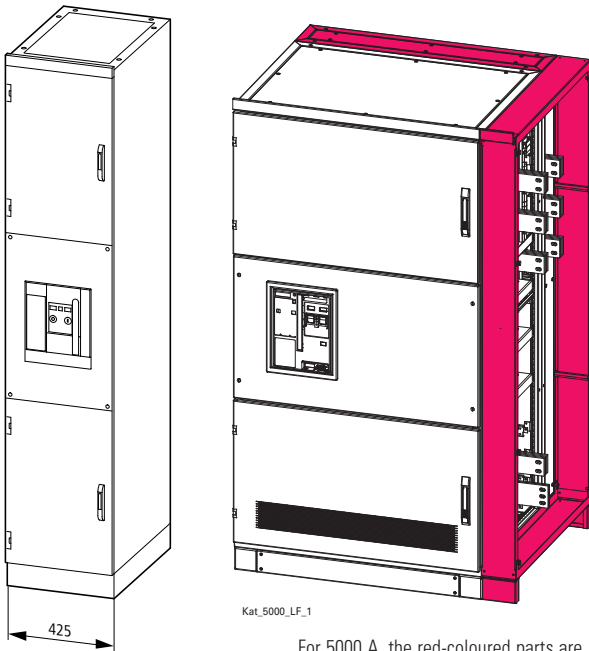

For 5000 A, the red-coloured parts are required in addition.

Section widths from 600 up to 1200 mm, internal separation up to Form 4

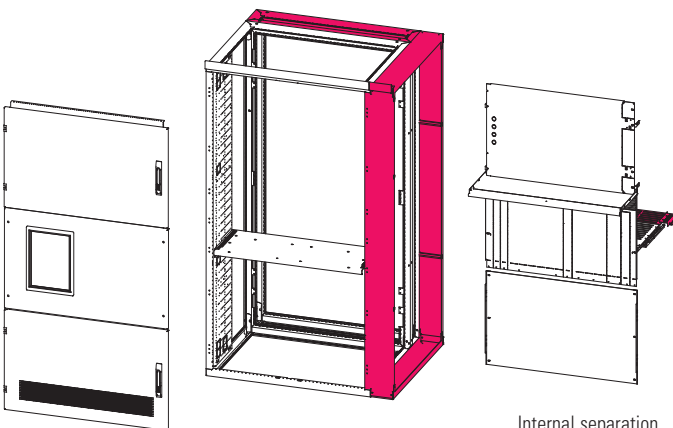

Base

For 5000 A, the red-coloured parts are required in addition.

Internal separation up to Form 4

For air circuit breakers IZM:

- in withdrawable or fixed design
- in 3-pole or 4-pole version
- as an incoming, outgoing or coupling switchgear or - with a top-mounted busbar - as an outgoing or incoming switchgear only
- for measuring purposes you can mount current transformers between the connection and the switchgear

For 5000 A

- for 5000 A, you need to use 2x(3x 80/10 Cu)
- as a general rule, for a 5000 A main busbar, you need to add an extra section of 200 mm depth to a section of 800 mm depth in order to create sufficient space for the second main busbar
- to be able to establish a section/section connection, it is compulsory to use an add-on frame of 175 mm width

Dimensions

- section widths of 425, 600, 800, 1000, 1100, 1200 or 1350 mm
- section height of 2000 mm, optionally with a plinth of 100 or 200 mm
- section depths of 600 or 800 mm; section depth of 800 mm only with rear-mounted busbar
- rated current I_b 5000 A = section depths is 1000 (800 + 200) mm

Connection area

- incoming supply lines from the top or from below; with top-mounted busbars incoming supply lines only possible from below
- connection directly to cable connector flags or
- drill-free connection to cable connection system over the total width accessible from the front

Internal separation from Form 1 up to Form 4:

- partition panels ready-to-fit for section equipment up to Form 4
- 2 switchgear area doors one on top and one below the device, as well as a cover with quick-acting locks (or with hinges at the center in front of the device) with IZMX16 and IZM26
- switchgear to be operated from outside
- doors ventilated or closed
- doors right or left-hinged
- areas not used for cable connection can be used to accommodate additional equipment, eg. controlgear or surge protection devices

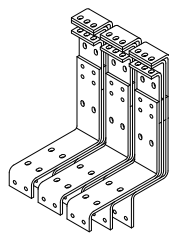

Direct cable connection

Central connection system up to 4000 A:
Cable connection system: drill-free connection over the total width of the section accessible from the front via feeder clip

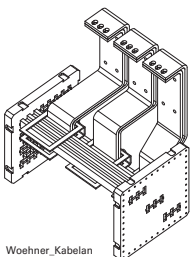

Woehner_Kabelan

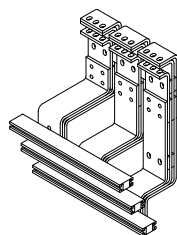

00160842_0

Cable connection system: drill-free connection over the total width of the section accessible from the front (typ: KCSIY)

XP Power sections - type of switchgear installation and section width for NZM

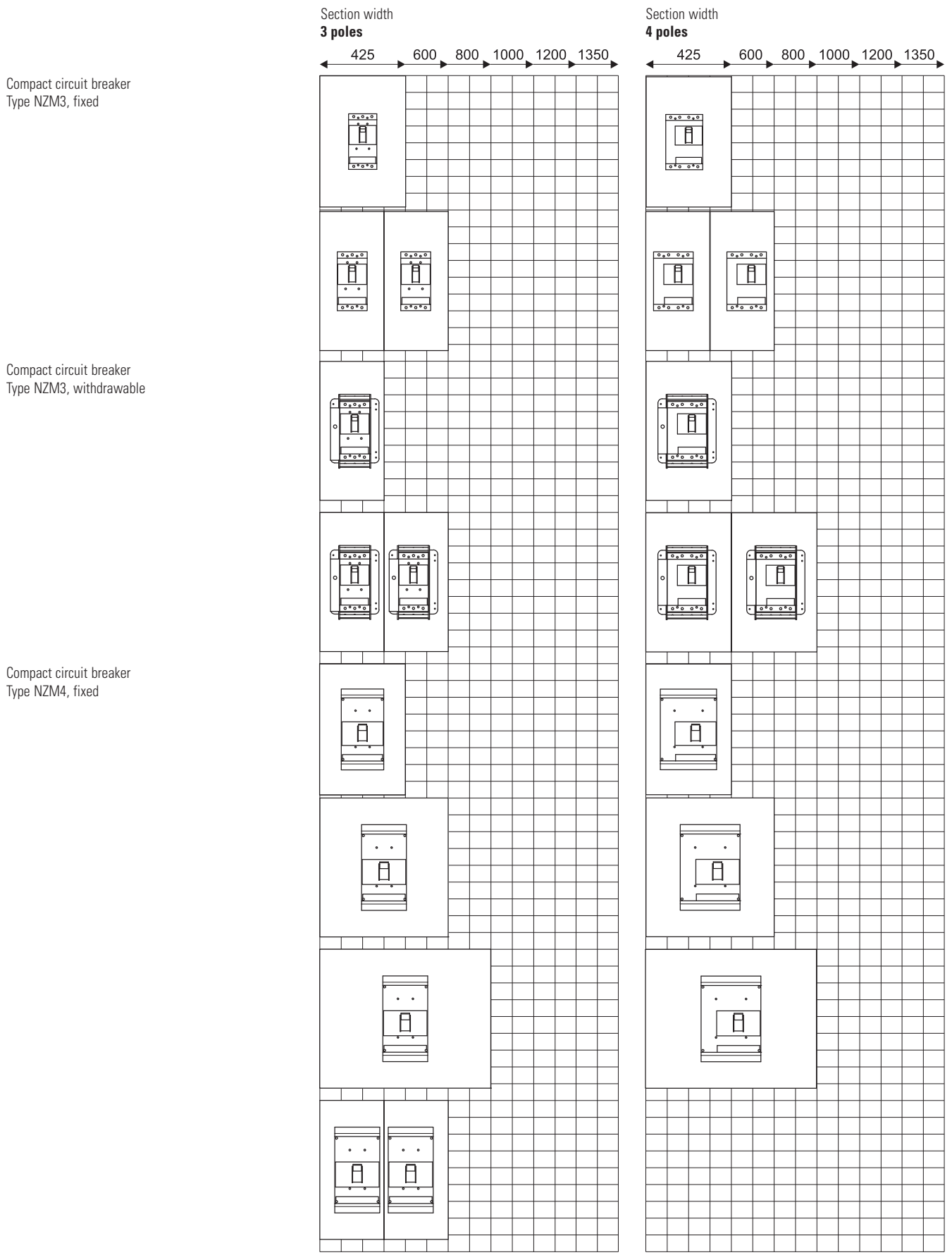

fk4810-1143d_13_07_1a

XP Power sections - type of switchgear installation and section width for NZM

Compact circuit breaker
Type NZM4, fixed

Compact circuit breaker
Type NZM4, withdrawable

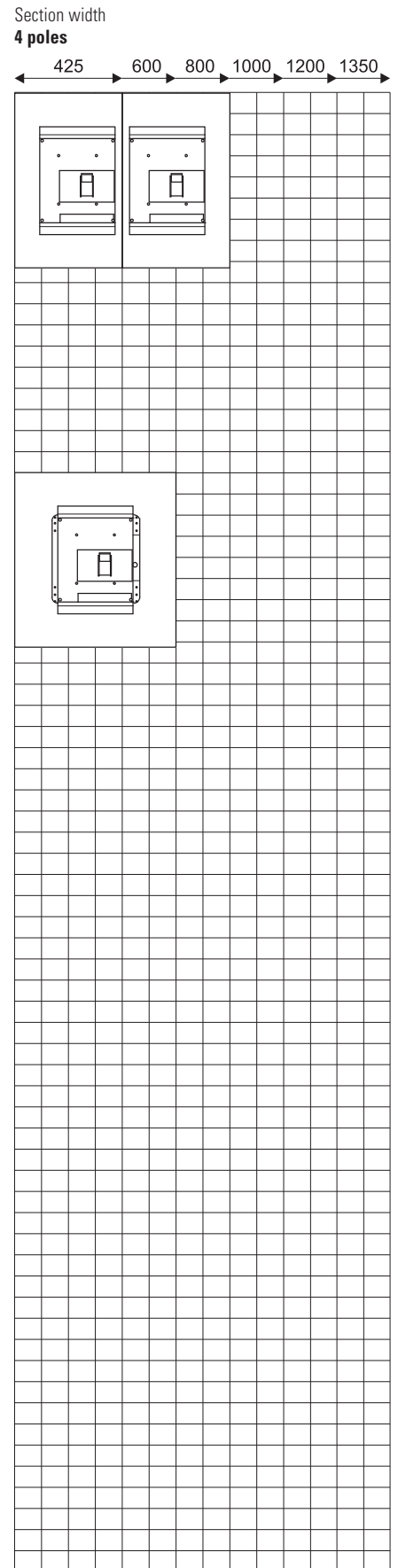
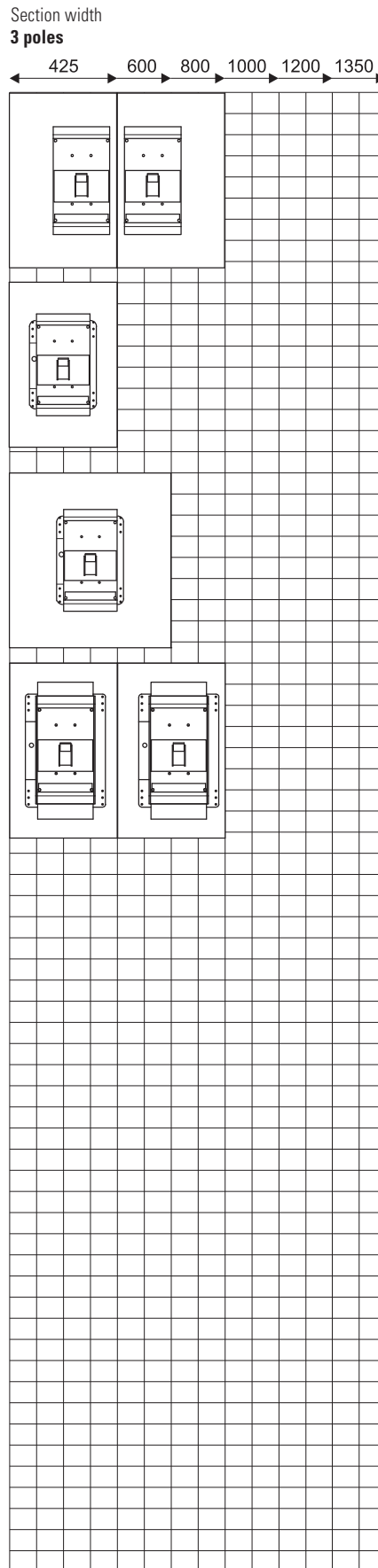

fk4810-1143d_13_07_1b

XP Power sections - type of switchgear installation and section width for IZMX16/IZM20/32/40/63

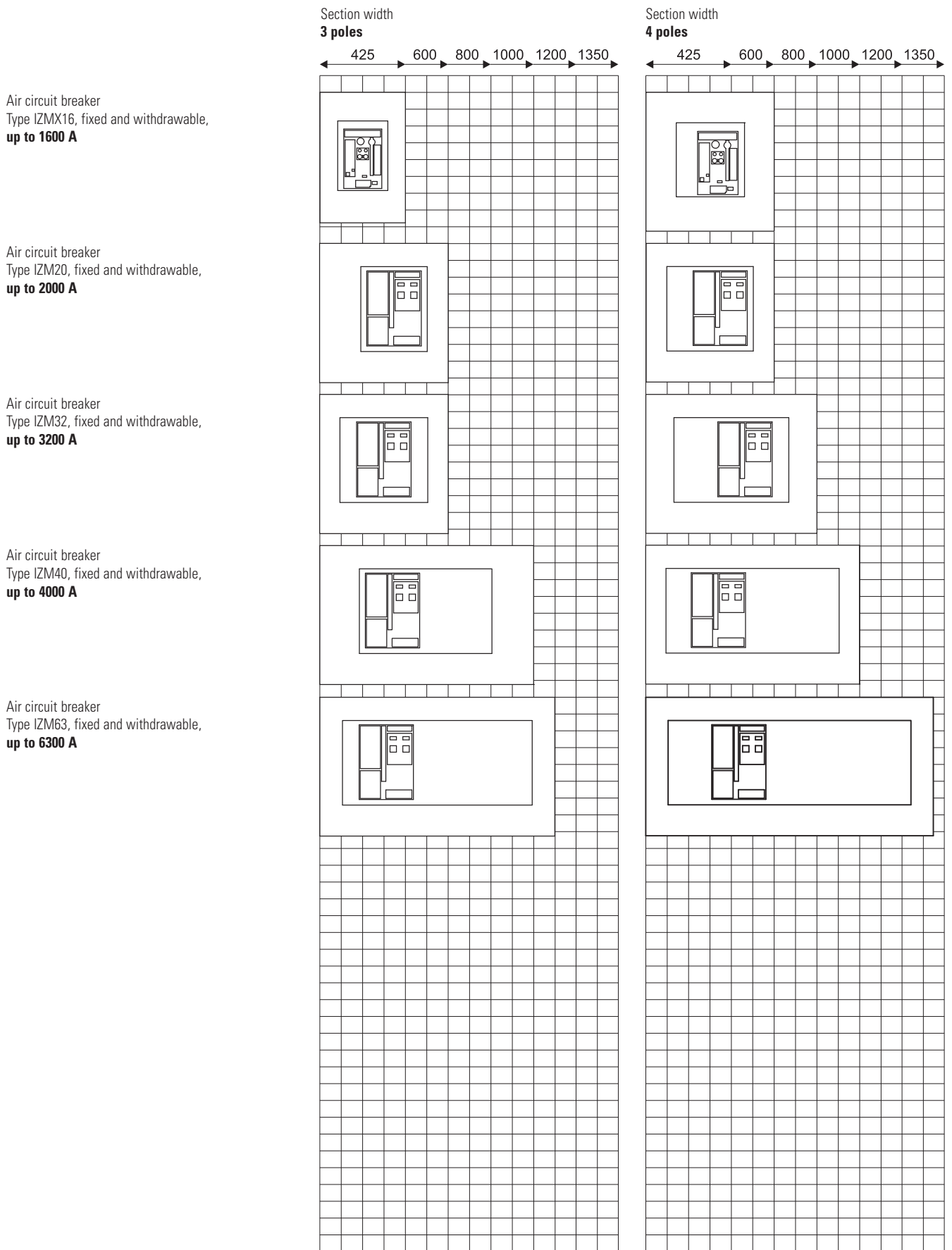

fk4810-1143d_13_07_1c

XF Outgoing sections for fixed modules up to 630 A, Form 2

Form 2

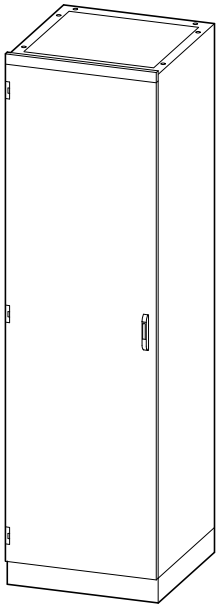

00155896_0

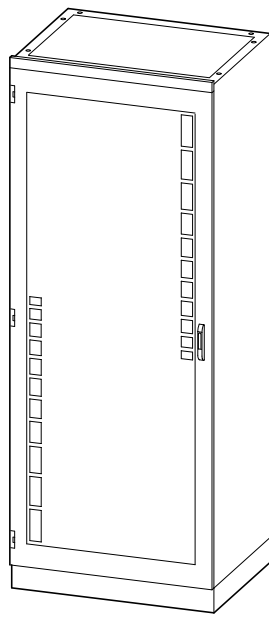

00160863_0

Section widths of 600, 800 or 1000 mm, with door either closed or transparent

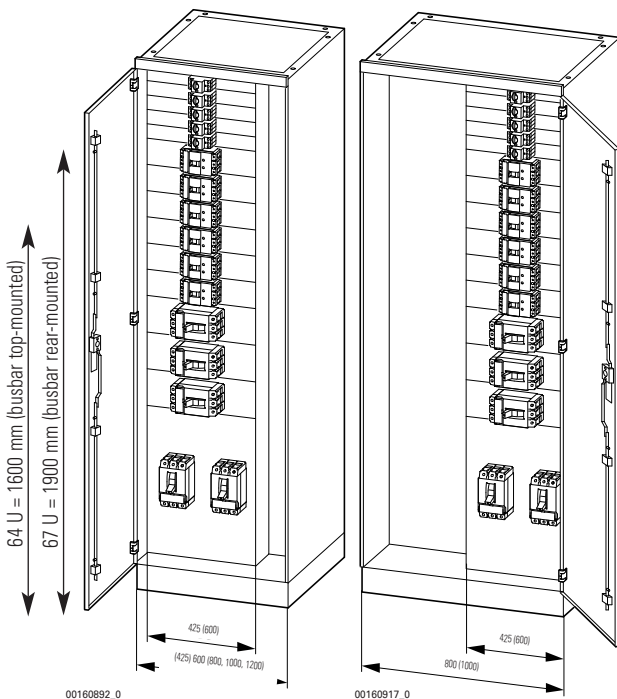

00160892_0

00160917_0

Cable connection area in different installation positions for widths of 200 and 400 mm.

- for **circuit breakers**, motor starters, miniature circuit breakers and fuse switch disconnectors
- **in horizontal and vertical position**
- Installation of the switchgear **on one mounting level** on mounting plates in the widths of 425 or 600 mm
- internal separation up to Form 2
- connection on the incoming side is provided for through a vertically arranged dropper bar system, covered to be touch-proof (through mounting plates).
- cable connection is provided for on the side, in the right or left part of the distributor section
- with a front door as high as the cabinet, ventilated, closed or transparent, door right or left-hinged
- switchgear to be operated behind the door or with an extension shaft and a rotary door coupling handle from outside

Horizontally fixed circuit breaker

	Module height (U/mm)	
	3 poles	4 poles
25 A	2/50	-
40 A	4/100	4/100
63 A	4/100	-
160 A	4/100	6/150
300 A	6/150	8/200
630 A	8/200 ¹⁾	10/250 ¹⁾

¹⁾ Horizontal installation of NZM3 (up to 630 A) only on modules of 600 mm width

Vertically fixed circuit breaker

	Module height ¹⁾ (U/mm)	Number of circuit breakers per module	
		425 mm	600 mm
160 A	12/300	2	3
300 A	16/400	2/1 ²⁾	3/2 ²⁾
630 A	24/600	1	2/1 ²⁾

¹⁾ Vertical installation of the switchgear preferably at the top/bottom of the section, depending on the cable insertion. In case of vertical installation it may be necessary to provide more height units for cable insertion.

²⁾ 4 poles

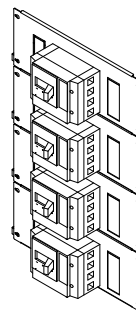

00160917_0

Installation of switchgear on pre-drilled mounting plates, with all fixing and connection openings prepared for installation.

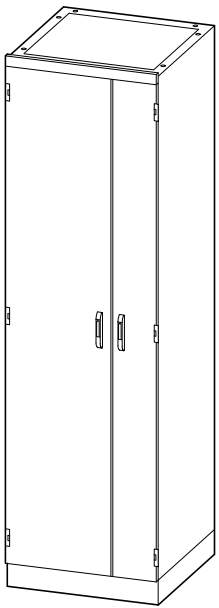

00160934_0

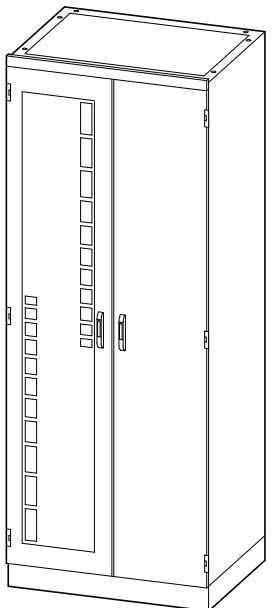

00160944_0

Section widths of 600, 800 or 1000 mm, with closed or transparent door

- for **circuit breakers**, motor starters, miniature circuit breakers and fuse switch disconnectors
- **in horizontal and vertical position**
- the switchgear will be installed **behind module covers** and are positioned **on one operating level**
- the module covers are provided with hinges; they can be turned which provides individual access to each module
- Mounting plates in the widths of 425 or 600 mm
- installation of internal separations up to Form 4¹⁾
- connection on the incoming side is provided for on a vertically arranged dropper bar system, covered to be touch-proof
- cable connection is provided for on the side, in the right or left part of the distributor section
- the connection area can be accessed via a separate door to the cable connection area and can be separated from busbars and switchgear area
- switchgear to be operated from outside, via cut-outs in the module covers
- can optionally be equipped with a front door as high as the cabinet, ventilated, closed or transparent, with right or left door hinges

¹⁾ It may be necessary to provide for more terminals.

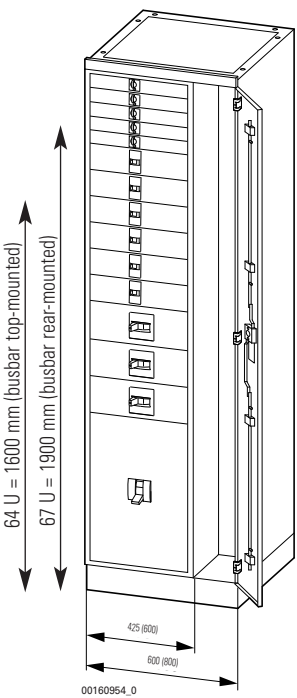

00160954_0

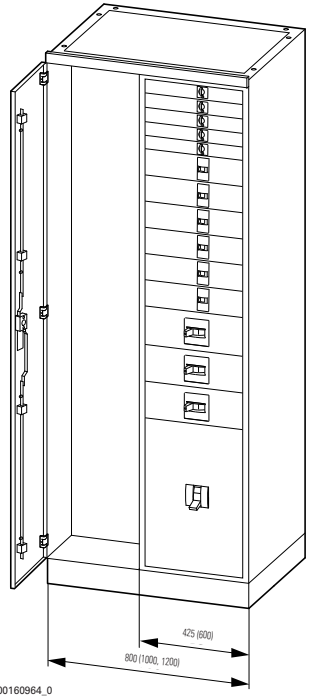

00160964_0

Cable connection area in different installation positions in the widths of 200 and 400 mm.

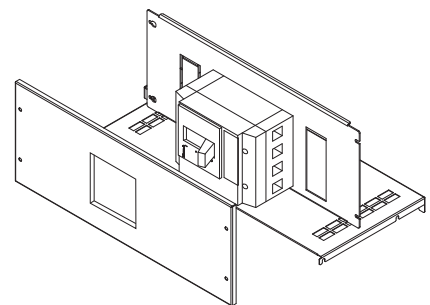

00122777_0

Installation of switchgear on pre-drilled mounting plates, with all fixing and connection openings prepared for installation. Swivel-mounted front cover comes with cut-out for operating the lever from outside.

For cable connection at the rear

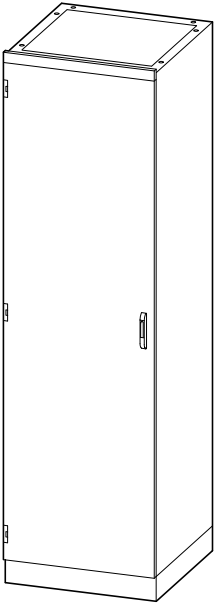

00155896_0

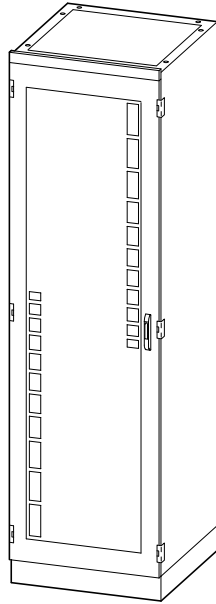

00155906_0

Section widths of 425 or 600 mm, with closed or transparent door

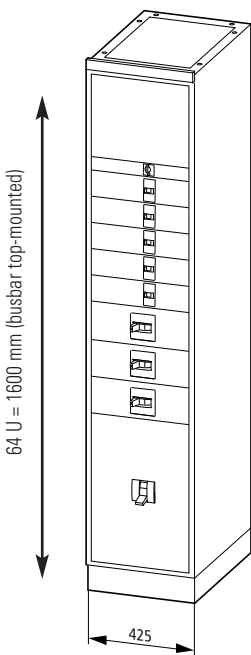

00155916_0

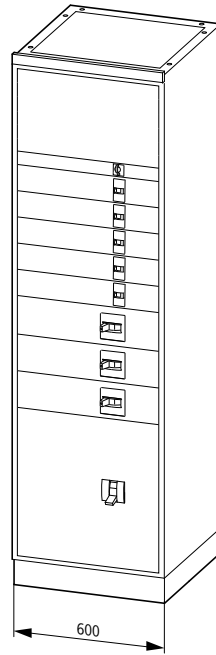

00155926_0

- for circuit breakers, motor starters and miniature circuit breakers
- **in horizontal and vertical position**
- the switchgear will be installed **behind module covers** and positioned **on one operating level**
- the module covers come with hinges; they can be turned which provides individual access to each module
- mounting plates in the widths of 425 or 600 mm
- connection on the incoming side is provided on a vertically arranged dropper bar system, covered so as to be touch-proof
- the cable connection area is at the left rear side, cable connection is done from the rear
- installation of internal separations up to Form 4
- switchgear to be operated from outside, via cut-outs in the module covers
- can optionally be equipped with a front door as high as the cabinet, ventilated, closed or transparent, with right or left door hinges
- only suitable for top-mounted busbars

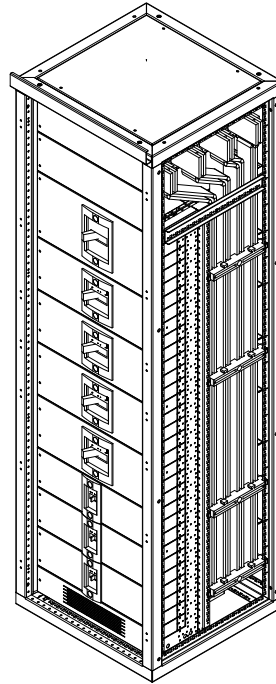

00163962_0

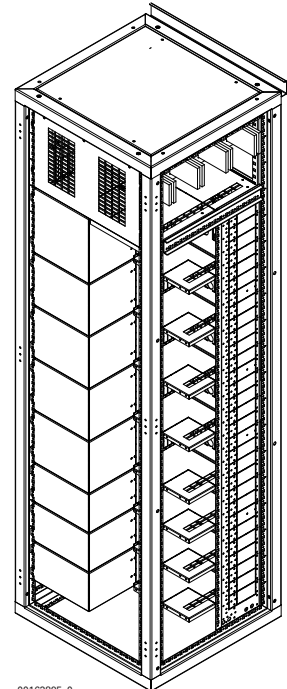

00163895_0

Cable connection from the rear reduces the section width.
Distributor must be accessible from the rear.

XF Outgoing sections without dropper bar for fixed modules up to 630 A

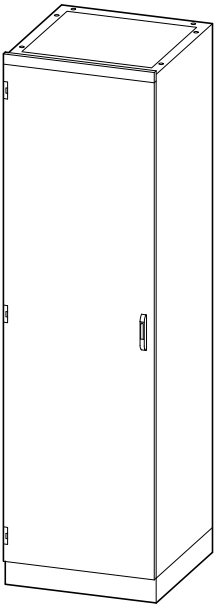

00155896_0

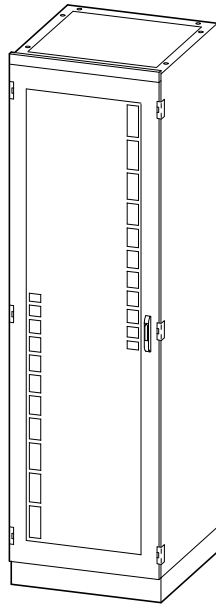

00155906_0

Section widths of 425, 600 mm, 800 and 1000 mm

- for **circuit breakers** and miniature circuit breakers
- **in vertical position**
- the switchgear are vertically mounted on mounting plates and can be mounted with an offset at any depth
- mounting plates available in widths of 425, 600, 800 or 1000 mm
- connection on the incoming side is directly on the main busbar
- main busbars can be covered so as to be touch-proof
- cable connection is done from below, either directly with the switchgear or to terminals mounted in the lower part of the section
- with a front door as high as the cabinet, ventilated, closed or transparent, with door hinged at the right or left side
- switchgear operation behind the door or from outside with an extension shaft and a rotary door coupling handle
- fitting frames can be used for front panels
- can be completely closed with front panels

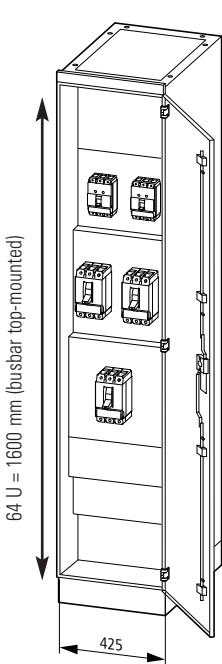

00160974_0

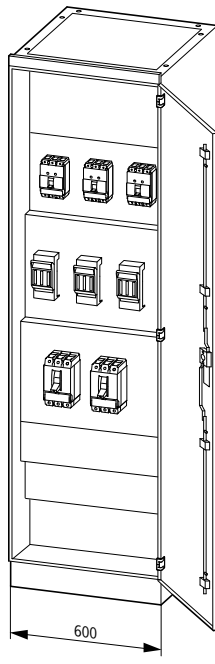

00160984_0

XF Outgoing sections (fixed installation), module heights and components: Horizontal installation of switchgear

Module width

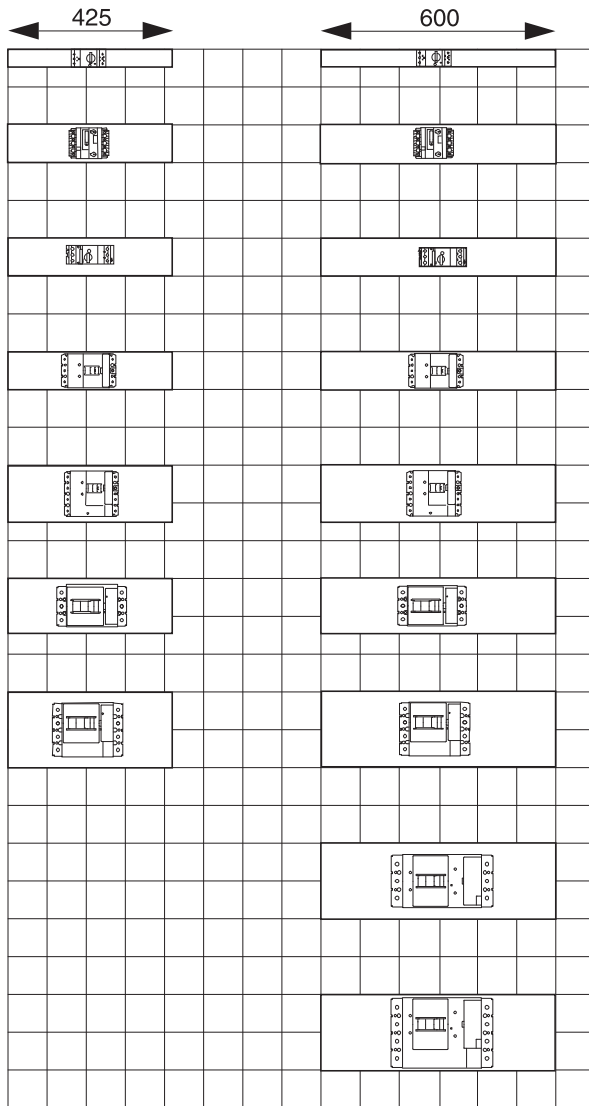

Motor-protective circuit breakers up to **32 A**
Type PKZM0, 2 U = 50 mm

Motor-protective circuit breakers up to **40 A**
Type PKZ2, 4U = 100 mm

Motor-protective circuit breakers up to **63 A**
Type PKZM4, 4 U = 100 mm

Circuit breakers up to **160 A, 3 poles**
Type NZM1, 4 U = 100 mm

Circuit breakers up to **160 A, 4 poles**
Type NZM1, 6 U = 150 mm

Circuit breakers up to **300 A, 3 poles**
Type NZM2, 6 U = 150 mm

Circuit breakers up to **300 A, 4 poles**
Type NZM2, 8 U = 200 mm

Circuit breakers up to **630 A, 3 poles**
Type NZM3, 8 U = 200 mm

Circuit breakers up to **630 A, 4 poles**
Type NZM3, 10 U = 250 mm

fk4810-1143d_13_13_1A4

XF Outgoing sections (fixed installation), module heights and components: Vertical installation of switchgear

Module width

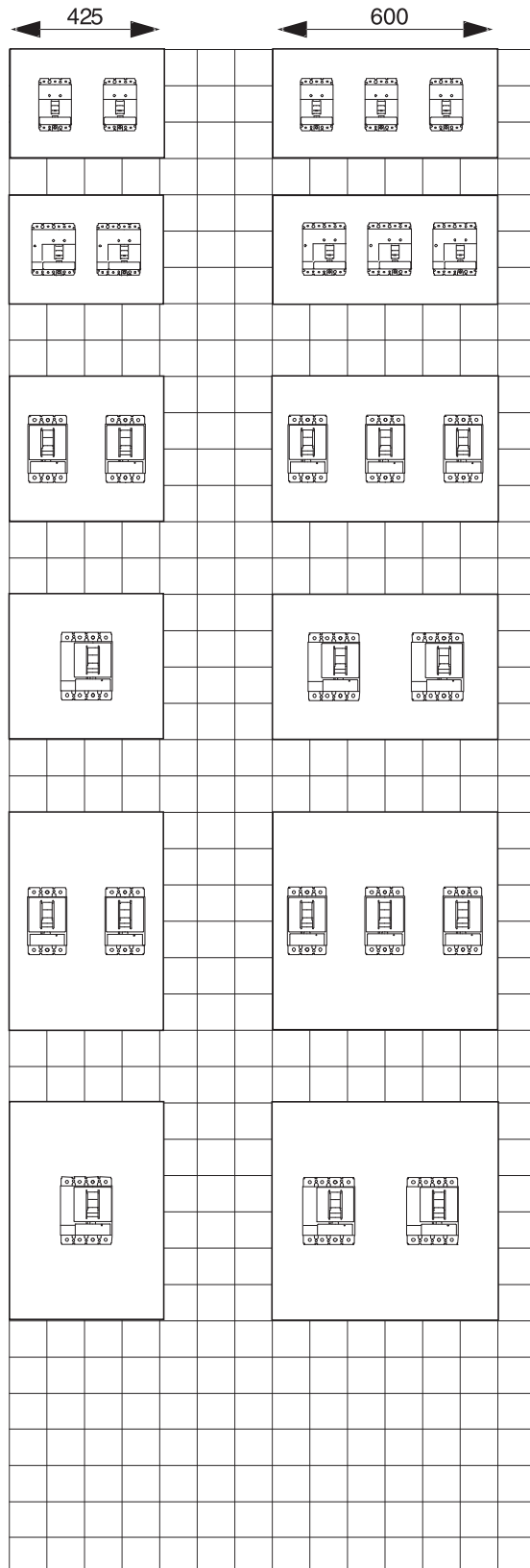

Circuit breakers up to **160 A, 3 poles**
Type NZM1, 12 U = 300 mm

Circuit breakers up to **160 A, 4 poles**
Type NZM1 with plug-in module, 12 U = 300 mm

Circuit breakers up to **300 A, 3 poles**
Type NZM2, 16 U = 400 mm

Circuit breakers up to **300 A, 4 poles**
Type NZM2, 16 U = 400 mm

Circuit breakers up to **300 A, with plug base, 3 poles**
Type NZM2, 24 U = 600 mm

Circuit breakers up to **300 A, with plug base, 4 poles**
Type NZM2, 24 U = 600 mm

fk4810-1143d_13_14A4

XF Outgoing sections (fixed design), module heights and components: Vertical installation of switchgear

Module width

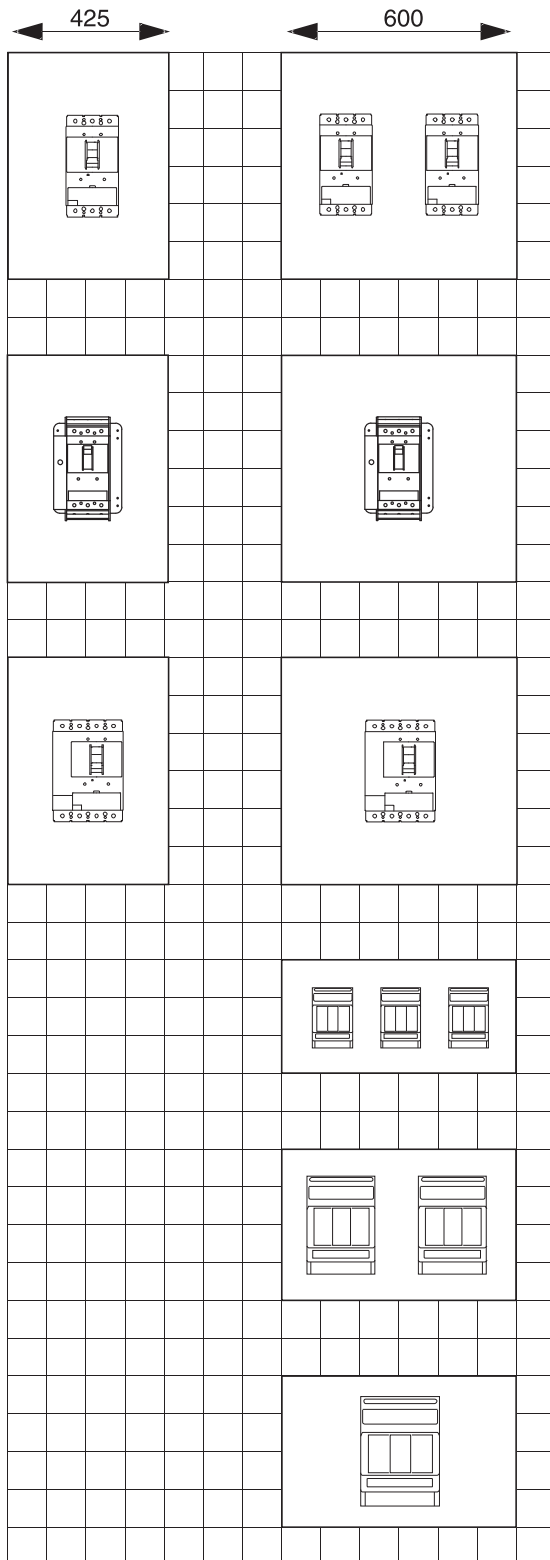

Circuit breakers up to **630 A, fixed, 3 poles**
Type NZM3, 24 U = 600 mm

Circuit breakers up to **630 A, with withdrawable unit, 3 poles**
Type NZM3, 24 U = 600 mm

Circuit breakers up to **630 A, fixed or with withdrawable unit, 4 poles**
Type NZM3, 24 U = 600 mm

Fuse base or fuse switch disconnectors up to **160 A, 3 poles**
Type GS1/GSTA1, 16 U = 400 mm

Fuse base or fuse switch disconnectors up to **250 A, 3 poles**
Type GS1/GSTA1, 16 U = 400 mm

Fuse base or fuse switch disconnectors up to **400 A, 3 poles**
Type GS1/GSTA1, 16 U = 400 mm

Rk4810-1143d_13_15A4

XF Outgoing sections for fixed installation module heights and components: Module covers for modular installation devices, measuring and command devices

Module width

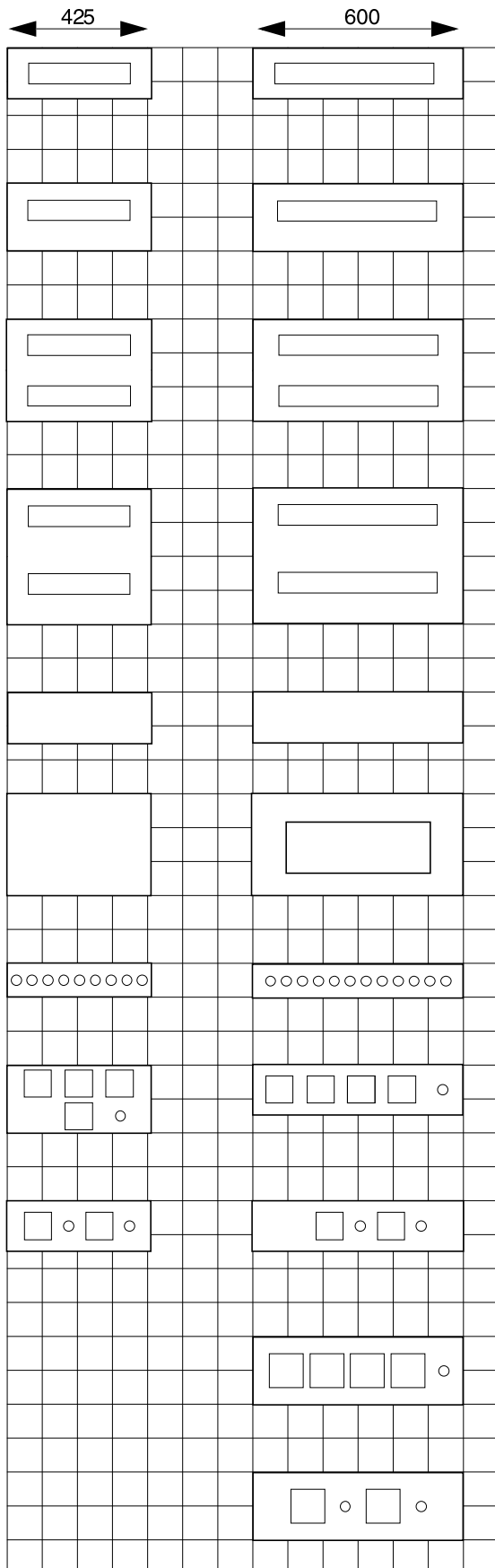

Modular installation devices /PKZ...

1 x 12 PE/1 x 24 PE, 6 U = 150 mm

1 x 12 PE/1 x 24 PE, 8 U = 200

2 x 12 PE/2 x 24 PE, 12 U = 300 mm

2 x 12 PE/2 x 24 PE, 16 U = 400 mm

Modules for terminals

6 U = 150 mm

12 U = 300 mm

Front covers

for **command and signalling devices**

9 x RMQ-Titan/12 x RMQ-Titan, 4 U = 100 mm

for **installation of measuring devices**

4 x 72 x 72 mm + 1 changeover contact

8 HE = 200mm/6 U = 150 mm

2 x 72 x 72 mm + 2 changeover contacts

6 U = 150 mm

4 x 96 x 96 mm + 1 changeover contact

8 U = 200 mm

2 x 96 x 96 mm + 2 changeover contacts

8 U = 200 mm

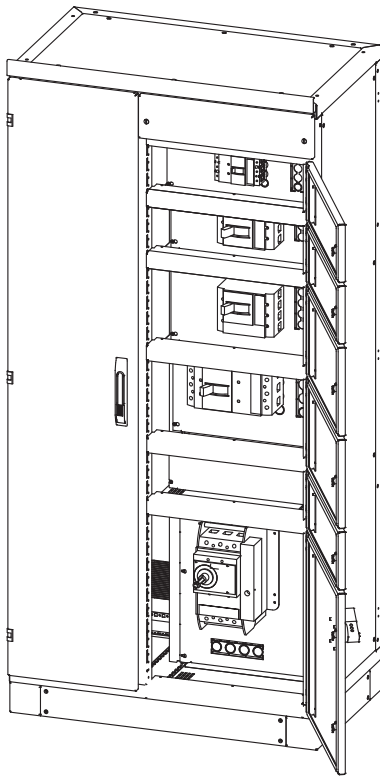

BS_3dansicht

- in the widths of 800, 1000 and 1200 mm
- module widths of 425/600 mm
- each module comes with its own door to the switchgear area
- 3 or 4 poles
- fixed or withdrawable
- suitable for switchgear with remote operation
- to be operated behind the door or with rotary door coupling handle
- dropper bars to be selected from 800-1600 A
- empty module plates for the setup of outgoing

Switchgear area:

- operation of switchgear **behind the door** or with **rotary door coupling handle**
- each module comes with its own door to the switchgear area
- mounting of the switchgear on pre-drilled mounting plates

Dropper bars:

- Center-to-center distance between phases 60 mm
- Rated current up to 1600 A
- Rated short-time withstand current I_{CW} up to 80 kA

Cable connection area:

- cable connection is implemented either from the top or from the bottom behind a separate door to the connection area
- connection of the individual modules is implemented directly on the switchgear
- side-mounted cable strain relief rails ensure a safe and neat guidance of cables
- vertical PE-, N or PEN rails are mounted in the cable connection area and can be equipped with connections for any outgoing cable

Box solution 4 - Heights and equipment

Circuit breakers NZM1

3/4 poles up to 160 A, H = 200 mm, 8U
 Mounting position: horizontal, Installation type: fixed/withdrawable

Module width 425 mm

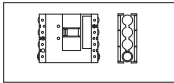

Module width 600 mm

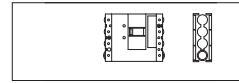

Circuit breakers NZM2

3 poles up to 300 A, H = 200 mm, 8U
 Mounting position: horizontal, Installation type: fixed/withdrawable

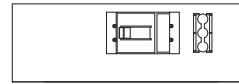
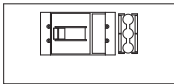

Circuit breakers NZM2

4 poles up to 300 A, H = 300 mm, 12U
 Mounting position: horizontal, Installation type: fixed/withdrawable

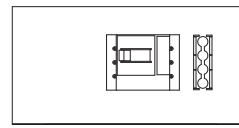
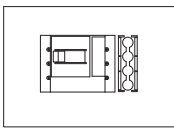

Circuit breakers NZM3

3/4 poles up to 630 A, H = 300 mm, 12U
 Mounting position: horizontal, Installation type: fixed

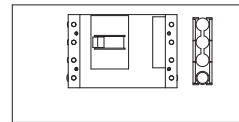

Circuit breakers NZM3

3/4 poles up to 630 A, H = 500 mm, 20U
 Mounting position: horizontal, Installation type: withdrawable

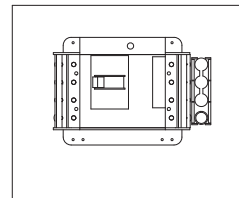

Circuit breakers NZM3

3/4 poles up to 630 A, H = 600 mm, 24U
 Mounting position: horizontal, Installation type: fixed/withdrawable

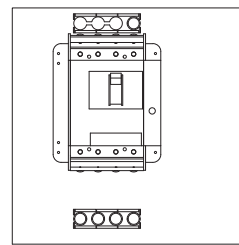
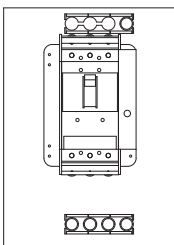

BS_425_NZM

BS_600_NZM

XF Outgoing sections - fixed design - Dimensions

XF section box solution

Motor Control Center - fixed design

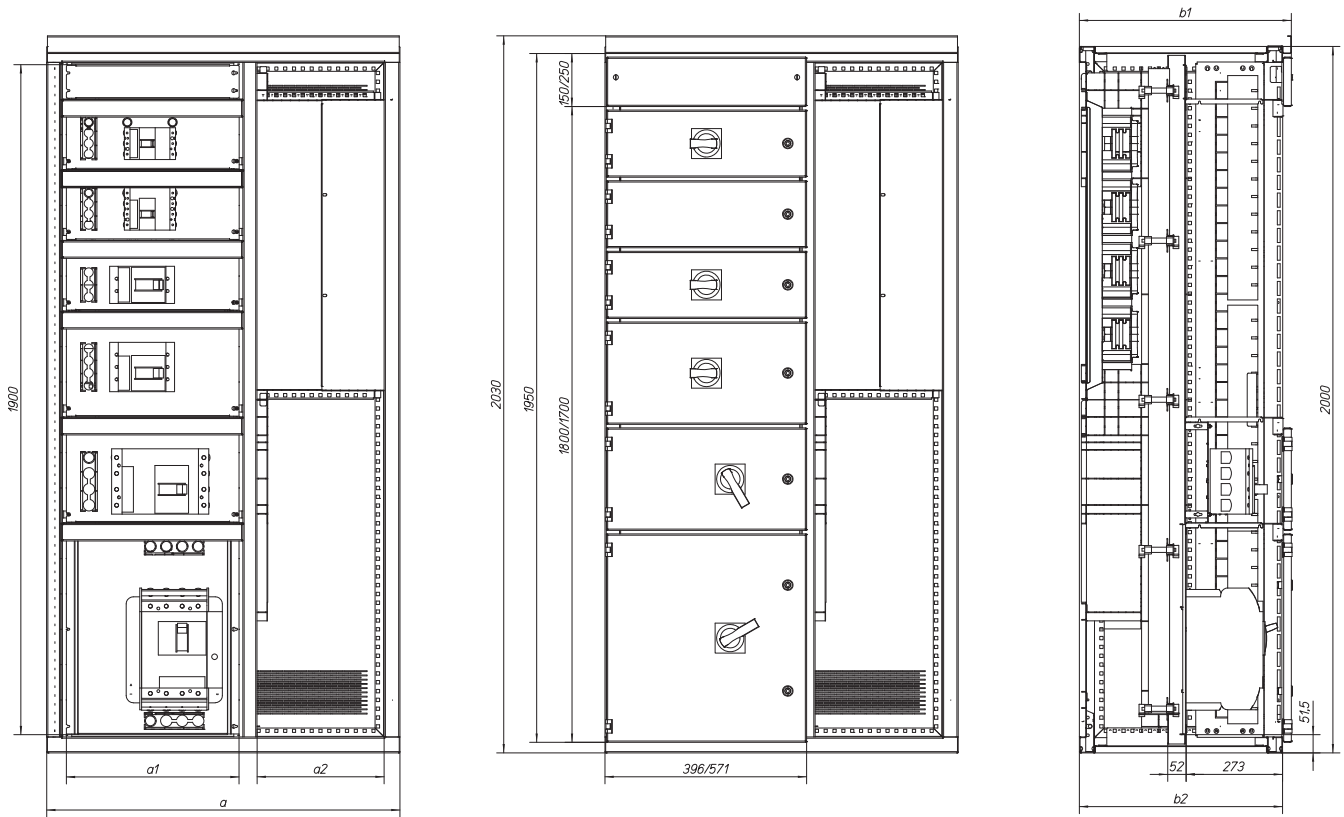

BS_abmessungen

b1	b2
600	575
800	775

a	a1	a2
600	314	135
800	314	335
800	489	160
1000	489	360
1200	489	560

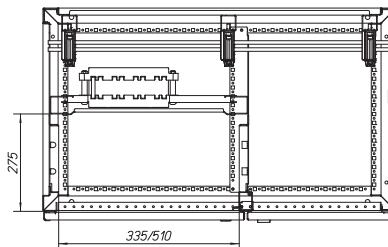

XF Outgoing sections fixed installation - Dimensions

XF section, mounting plates box solution

XMN...M...-BS

Version I

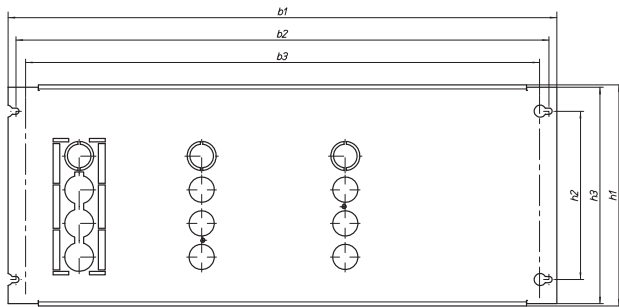

BS_mounting plates_V1

Type	H1	B1	H2	B2	H3	B3
XMN130804M-BS	197	314	150	300	190	283
XMN230804M-BS	197	314	150	300	190	283
XMN241204M-BS	297	314	250	300	290	283
XMN130806M-BS	197	489	150	475	190	458
XMN230806M-BS	197	489	150	475	190	458
XMN241206M-BS	297	489	250	475	290	458
XMN341206M-F-BS	297	489	250	475	290	458

Version II

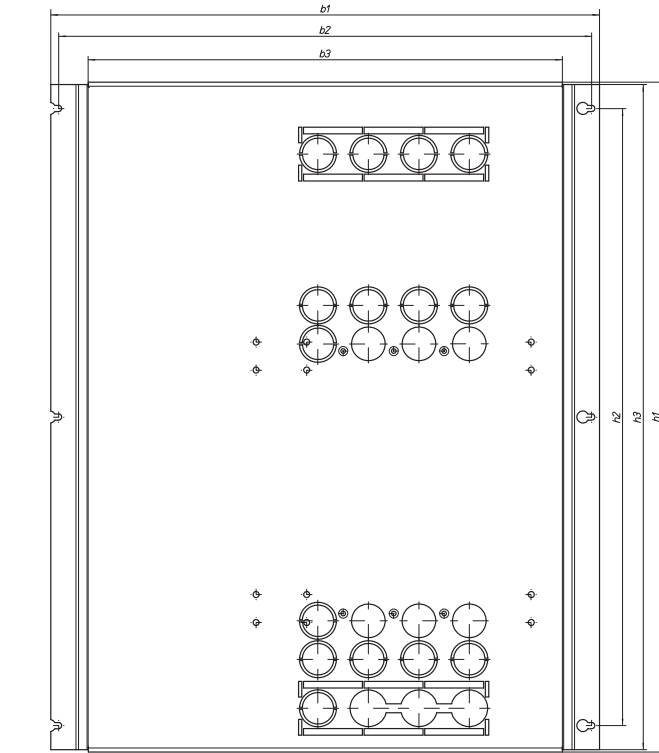

BS_mounting plates_V2

Type	H1	B1	H2	B2	H3	B3
XMN342404M-BS	597	314	550	300	590	247
XMN342006M-W-BS	497	489	450	475	490	422
XMN342406M-BS	597	489	550	475	590	422

XF Outgoing sections - fixed design - for fuse switch disconnectors

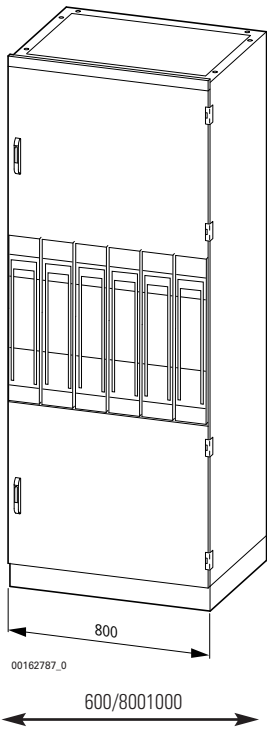

Section widths of 600, 800 and 1000 mm,
internal separation Form 2

Fuse strips can only be used with rear-mounted busbars. Please respect the max. current carrying capacity of the fuse strips depending on the ambient temperature, the degree of protection and the number of fuse strips per section in accordance with the xEnergy technical data.

- for **fuse switch disconnectors SL, Jean Müller/Wöhner/M.Schneider/Pronotec**
- with single break feature
- in **vertical** mounting position

Switchgear area:

- **Operation** of the fuse strips **from outside or behind the door**
- Connection of fuse strips on the incoming side on a horizontally arranged dropper bar system
- Dropper bars are accessible from the front over the entire section width
- Thanks to a cover frame variable in depth, it is possible to use fuse strips from different manufacturers without having to change the dropper bar in depth, which ensures a neat closing between the cover frame and the fuse strips. The cover frame (**XSMLV-I-CH..**) is not part of the fitting kit and needs to be ordered separately according to the section width.

Dropper bars:

- Center-to-center distance between phases 185 mm
- Rated current up to 1600 A
- Rated short-time withstand current I_{CW} up to 65 kA

Cable connection area:

- Cable connection is implemented from the top or bottom
- Connections of fuse strips can be covered for protection against accidental contact
- Cable strain relief rails assure safe guidance of outgoing cables
- The connection area is accessible via a separate door to the cable connection area and can be sealed off from the busbar and switchgear area.
- Areas not used for cable insertion can be used to accommodate additional equipment, e.g. controlgear

Type	I_e up to A	Size mm
SL00	160	50
SL1	250	100
SL2	400	100
SL3	630	100

Section width mm	Max. installation space mm
600	500
800	700
1000	900

XF Outgoing sections fixed installation for fuse switch disconnectors - Dimensions

XF Outgoing sections fixed installation for fuse switch disconnectors SL, vertical XSMLV

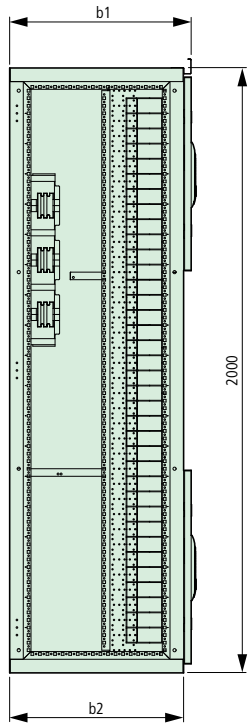

00162369_0

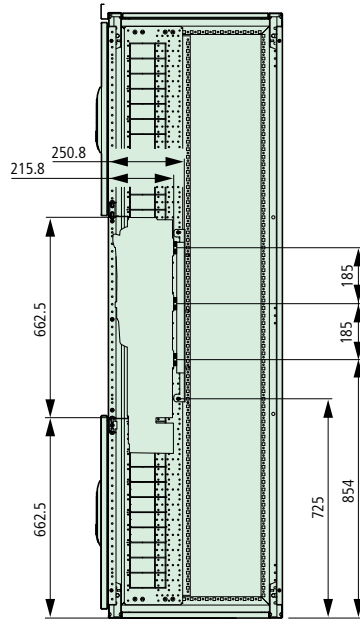

00162189_0

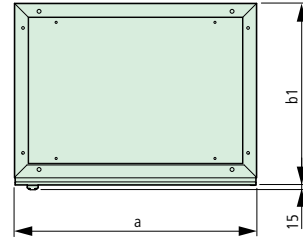

00162389_0

b_1	b_2
600	575
800	775

a
600
800
1000

XF Outgoing sections - fixed design - for fuse switch disconnectors with section dropper bar across two sections

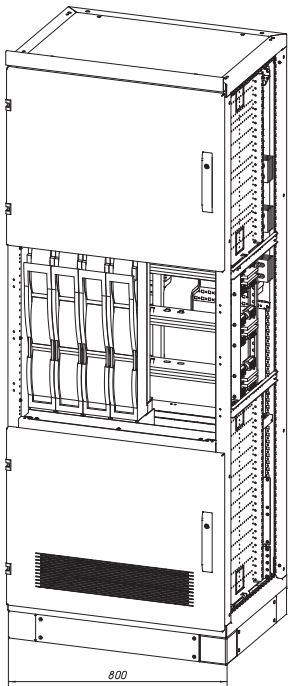

XFMLV_I

Fuse strips can only be used with rear-mounted busbars. Please respect the max. current carrying capacity of the fuse strips depending on the ambient temperature, the degree of protection and the number of fuse strips per section in accordance with the xEnergy technical data.

- for **fuse switch disconnectors (SL)** - Manufacturer: EATON
- with single break feature
- in **vertical** mounting position

Switchgear area:

- **Operation** of the fuse strips **from outside or behind the door**
- connection of fuse strips to a horizontally positioned double busbar system with 12.5 mm distance between the busbar pairs
- dropper bars are accessible from the front, over the entire section width
- Thanks to a cover frame variable in depth, it is possible to use fuse strips from different manufacturers without having to change the dropper bar in depth, which ensures a neat closing between the cover frame and the fuse strips. As the front cover frame is level with the fuse strip, you can always use the same empty-space cover, even with different types of fuse strips. The cover frame (**XFMLV-I-CH..**) is not part of the fitting kit and needs to be ordered separately according to the section width.

Cable connection area:

- Cable connection is implemented from the top or bottom
- Connections of fuse strips can be covered for protection against accidental contact
- Cable strain relief rails assure safe guidance of outgoing cables
- The connection area is accessible via a separate door to the cable connection area and can be sealed off from the busbar and switchgear area.
- Areas not used for cable insertion can be used to accommodate additional equipment, e.g. controlgear

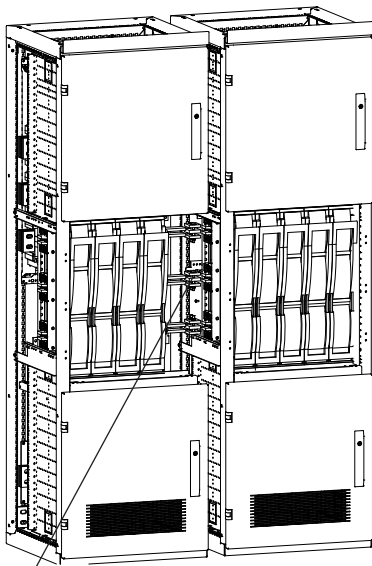

XFMLV_AnsI_2

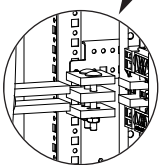

Push CU flaps between and over the dropper bar(s) and tighten to the right torque (20Nm).

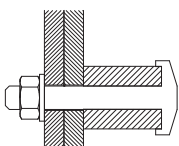

XFMLV_I_Detail_a

Individual holes punched into the dropper bar ensure that the space between the connections from the main busbar to the dropper bar can be used for accommodating fuse strips.

Type	I_e up to A	Size mm
SL00	160	50
SL1	250	100
SL2	400	100
SL3	630	100
Section width mm	Max. installation space mm	
600	500	
800	700	
1000	900	

Dropper bar:

- Easy connecting of the dropper bars from section to section thanks to flat copper flaps in the respective dropper bar thickness used in each case. Following the mechanical connection of the switchboard cabinets, the flaps are pushed over the dropper bars of the busbars you wish to connect, and then tightened to the respective torque using a torque wrench. To make it easier to bring the flaps into the right position, you will need to remove two fuse strips from one of the two switchboard cabinets. Once the job on the electrical connections has been finished, the fuse strips can be fixed and secured again.
- up to 40% of the copper can be saved by not using a main busbar in SL-I cabinets.
- Center-to-center distance of 185 mm between the phases
- Rated current 1600–3200 A
- Rated short-time withstand current $I_{CW} = 80kA$

XF Outgoing sections - fixed design - for fuse switch disconnectors with section dropper bar across two sections - Dimensions

XF section with dropper bar across two sections and vertically installed SL fuse switch disconnectors
XSMLV-I

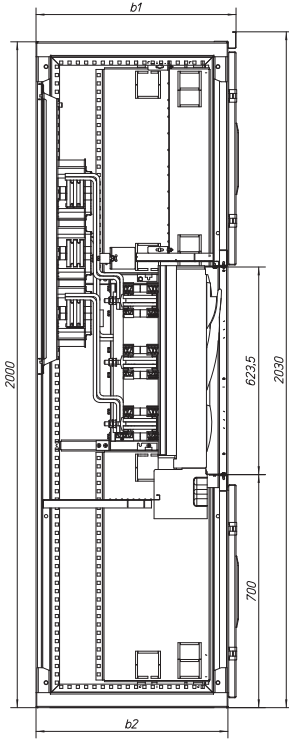

XSMLV-I_Page_1

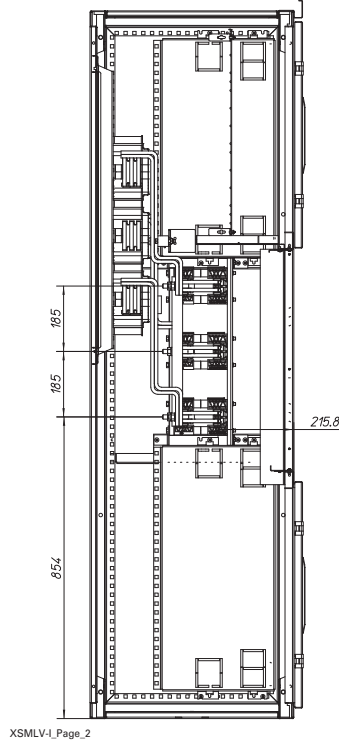

XSMLV-I_Page_2

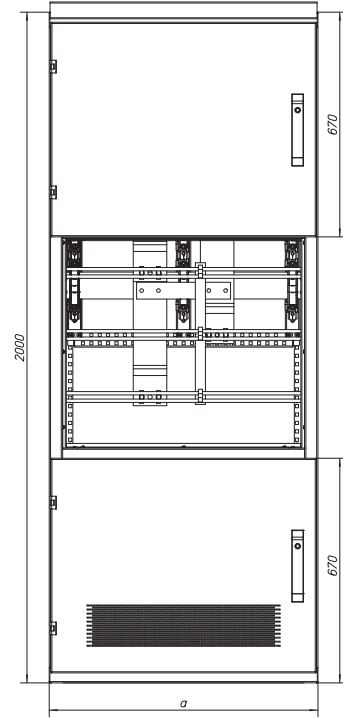

XSMLV-I_Front_2

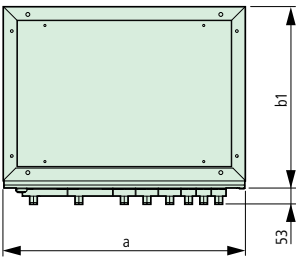

00162379_0

b1	b2
600	575
800	775
1000	975

a	c
600	500
800	700
1000	900

XR Outgoing sections for removable design and switch fuse units

Functional areas

Busbar rear-mounted

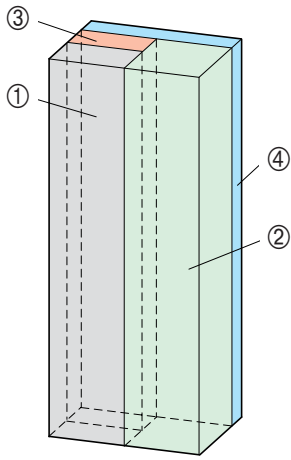

00156267_0

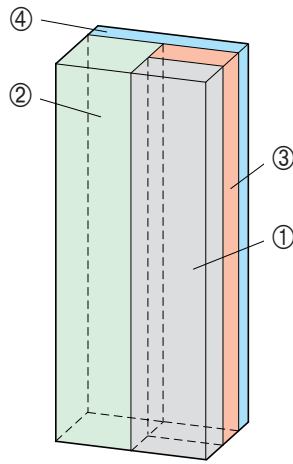

00155856_0

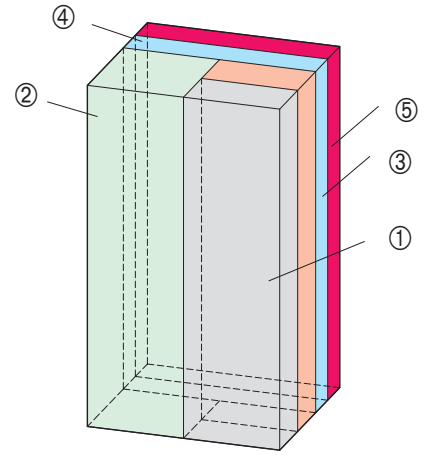

Kat_5000_funks_r

- 1 Switchgear area
- 2 Cable connection area

- 3 Dropper bars
- 4 Main busbars

- 5 additional main busbar section for 5000 A

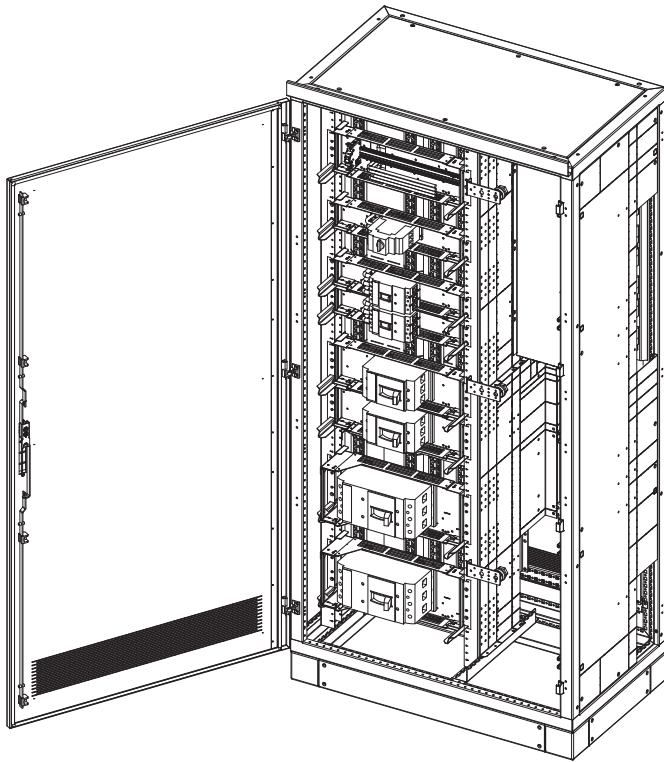

XE-Katalog-Pl-2b

- in the widths of 800, 1000 and 1200 mm
- 3 or 4 poles
- IP31/55
- consistent mounting height of switchgear
- single-wing section door with 800/1000 mm, double-wing with 1200 mm
- suitable for switchgear with remote operation
- operation behind the door
- dropper bar to be selected from 800-1600 A
- separate setup in 2 separate sections possible, e.g. 600/600 mm switchgear area/cable connection area
- plug-in module - empty module for RCD, FAZ, ...
- switchgear area and cable connection area can be used vice-versa
- max. height available (for placing equipment) 1900 mm

Switchgear area:

- operation of the switchgear **behind the door**
- Contacting of modules on the incoming side to a vertically arranged bar system
- dropper bars are accessible from the front over the entire height of the section

Dropper bars:

- Center-to-center distance of phases 185 mm
- Rated current up to 1600 A
- Rated short-time withstand current I_{CW} up to 80 kA

Busbar I_e A	Busbar cross-section L1, L2, L3, full N mm ²	Max. center-to-center distance between busbar carrier r_1 mm für I_{CW} (1s)					
		35 kA	45 kA	50 kA	65 kA	80 kA	100 kA
800	1 x 40 x 10	600	600	600	450	450	-
1000	1 x 60 x 10	600	600	600	450	450	-
1250	1 x 80 x 10	600	600	600	450	450	-
1600	1 x 100 x 10	600	600	600	450	450	-

Cable connection area:

- cable connection is implemented from the top or from the bottom
- plug-in modules are either directly connected to the switchgear or to terminals separately coming out of the module
- side-mounted cable strain relief rails assure a safe and neat cable guidance
- vertical PE, N or PEN rails are mounted in the cable connection area and can be equipped with terminals for any outgoing cable

Plug-in technology 2 - Heights and equipment



Motor-protective circuit breakers
PKZM0 up to 32 A, PKZM2 up to 40 A, PKZM4 up to 63 A
H = 100 mm



Circuit breakers
NZM1/3 poles up to 160 A
H = 100 mm

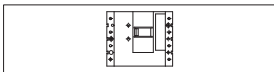

Circuit breakers
NZM1/4 poles up to 160 A
H = 150 mm

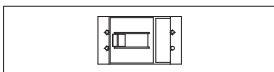

Circuit breakers
NZM2/4 poles up to 300 A
H = 150 mm

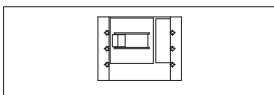

Circuit breakers
NZM2/4 poles up to 300 A
H = 200 mm

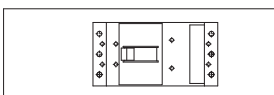

Circuit breakers
NZM3/3 poles up to 630 A
H = 250 mm

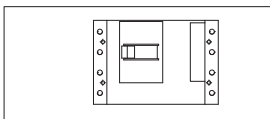

Circuit breakers
NZM3/4 poles up to 630 A
H = 300 mm



Drawer-unit module
with device carrying rail
H = 150 mm

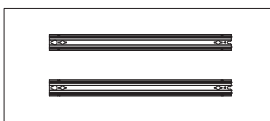

Drawer-unit module
with two device carrying rails
H = 250 mm

XE-Stecktechnik-Schalter-2b

XE-Stecktechnik-Schalter-2b

XR Outgoing sections for plug-in module technology up to 630 A, Form 2 - Dimensions

XR section using plug-in module technology, Form 2

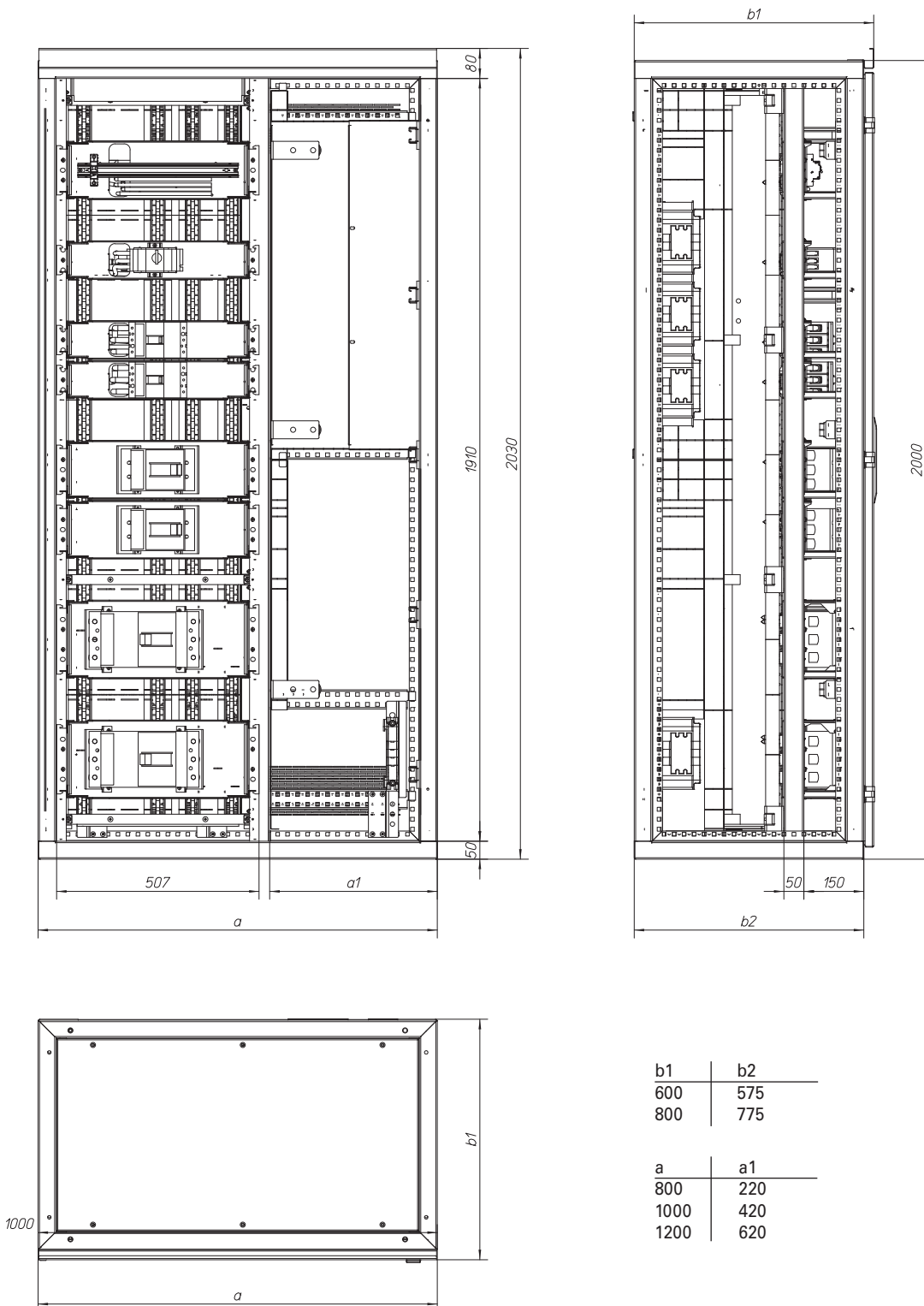

Ansicht_Kasten_2b

XR Outgoing sections for plug-in module technology up to 630 A, Form 2 - Dimensions

Main dimensions of plug-in modules in Form 2

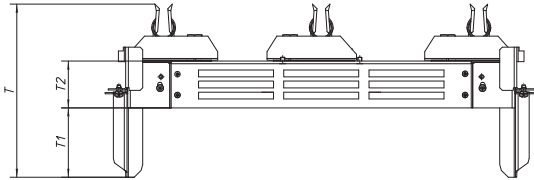
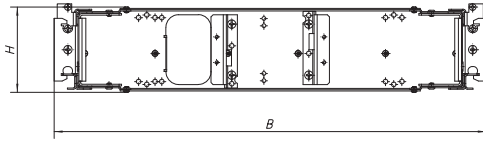

BS_Module_2b_Abmess

Type	B	H	T	T1	T2
NZM1 3p H100	507	100	203	81,5	55
NZM2 3p H150	507	150	202	81,5	55
NZM3 3p H200	507	200	206	8,5	125
Empty module H150	507	150	206	81,5	55
PKZ H100	507	100	203	81,5	55
NZM1 4p H150	507	150	203	81,5	55
NZM2 4p H200	507	200	203	81,5	55
NZM3 4p H250	507	250	206	8,5	125
Empty module H250	507	250	203	81,5	55

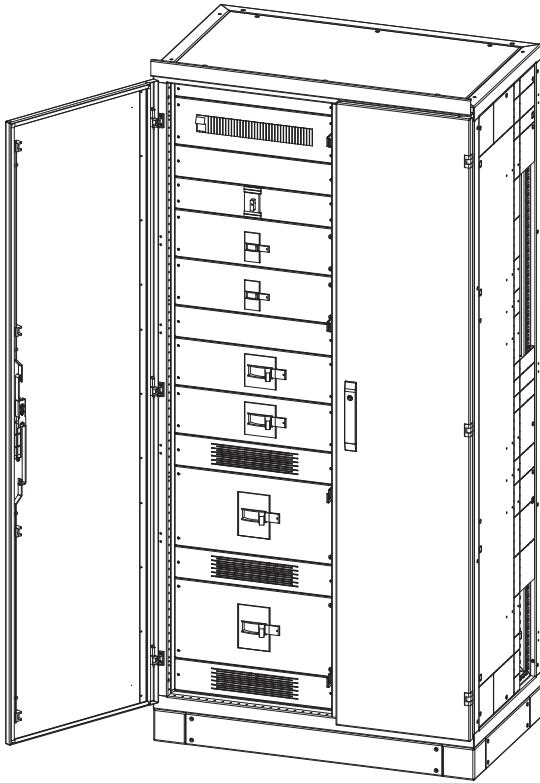

XE-NZM-PI-4a

- in the widths of 800, 1000 and 1200 mm
- 3 or 4 poles
- IP31/55
- each module comes with its own front panel
- separate door to switchgear area and connection area
- transparent doors are available (glass door)
- empty plug-in module for mounting RCD, FAZ, ...
- to be operated behind the door
- dropper bar to be selected from 800-1600 A
- separate setup in 2 separate sections is possible, e.g. 600/600 mm switchgear area/cable connection area
- max. height available (for placing equipment) = 1900 mm

Switchgear area:

- operation of the switchgear **behind the separate door to switchg. area**
- each module is equipped with its own front panel
- contacting of modules on the incoming side to a vertically arranged bar system
- dropper bars are accessible from the front over the entire height of the section

Dropper bars:

- Center-to-center distance of phases 185 mm
- Rated current up to 1600 A
- Rated short-time withstand current I_{CW} up to 80 kA

Busbar I_e	Busbar cross- section L1, L2, L3, full N	Max. center-to-center distance between bus-bars carrier in mm for I_{CW} (1s)					
		35 kA	45 kA	50 kA	65 kA	80 kA	100 kA
A	mm ²	mm	mm	mm	mm	mm	mm
800	1 x 40 x 10	600	600	600	450	450	-
1000	1 x 60 x 10	600	600	600	450	450	-
1250	1 x 80 x 10	600	600	600	450	450	-
1600	1 x 100 x 10	600	600	600	450	450	-

Cable connection area:

- cable connection is implemented from the top or from the bottom behind a separate door to the connection area
- plug-in modules are either directly connected to the switchgear or to terminals separately coming out of the module
- side-mounted cable strain relief rails assure a safe and neat cable guidance
- vertical PE, N or PEN rails are mounted in the cable connection area and can be equipped with terminals for any outgoing cable

Plug-in module technology 4 - Heights and equipment, modules incl. front panel



Motor-protective circuit breakers
PKZM0 up to 32 A, PKZM2 up to 40 A,
PKZM4 up to 63 A
H = 100 mm



Circuit breakers
NZM1/3 poles up to 160 A
H = 100 mm

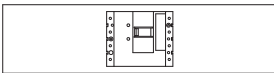

Circuit breakers
NZM1/4 poles up to 160 A
H = 150 mm

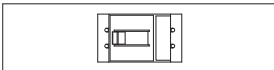

Circuit breakers
NZM2/4 poles up to 300 A
H = 150 mm

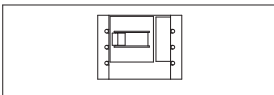

Circuit breakers
NZM2/4 poles up to 300 A
H = 200 mm

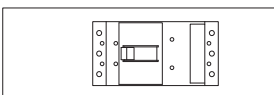

Circuit breakers
NZM3/3 poles up to 630 A
H = 200 mm

XE-Steck-Katalog-Schalter-4b

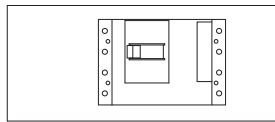

Circuit breakers
NZM3/4 poles up to 630 A
H = 250 mm



Drawer-unit module
with device carrying rail
H = 150 mm

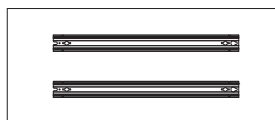

Drawer-unit module
with two device carrying rails
H = 250 mm

XE-Steck-Katalog-Schalter-4b

XR Outgoing sections for plug-in module technology up to 630 A, Form 4 - Dimensions

XR section using plug-in module technology, Form 4

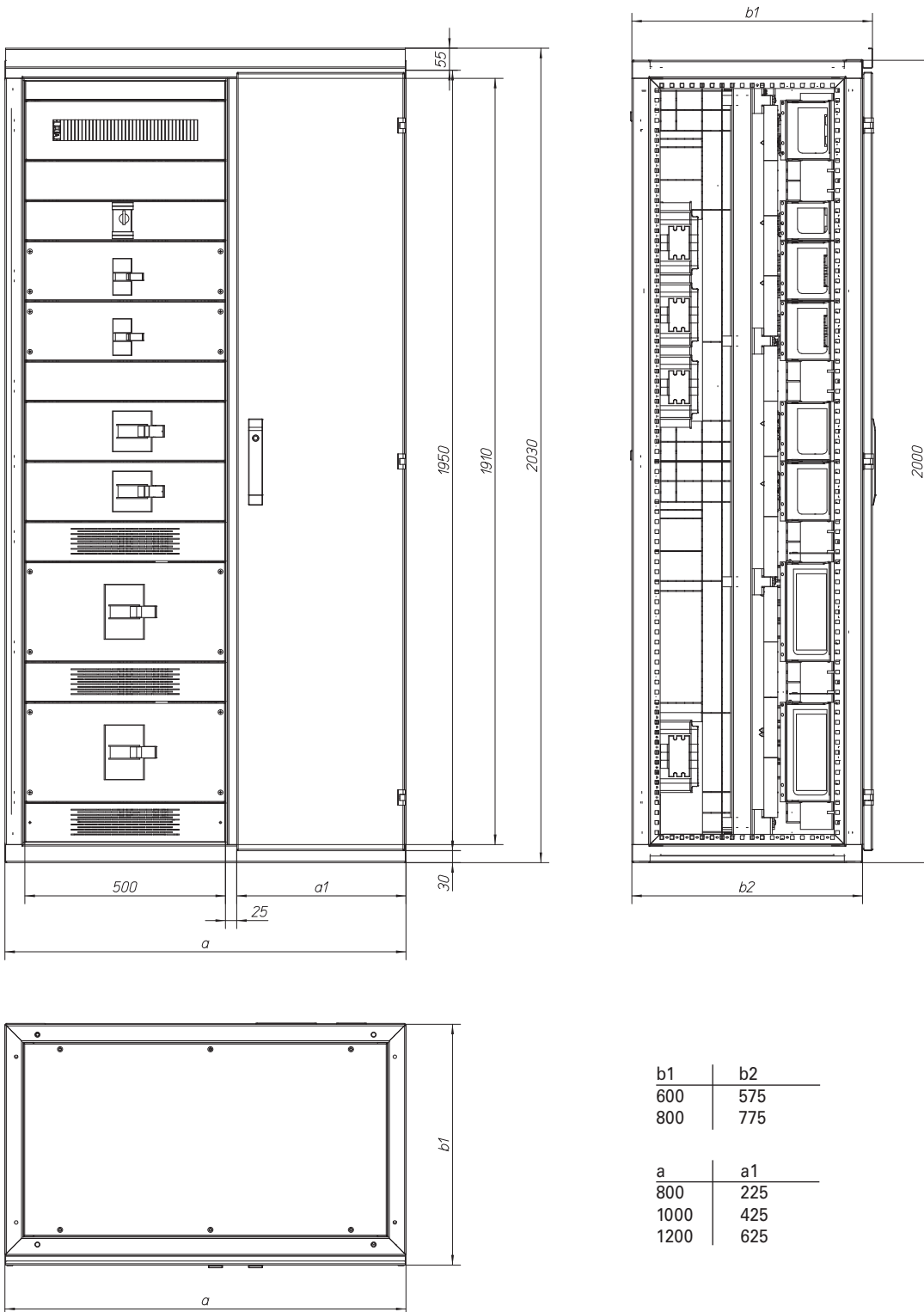

Ansicht_Kasten_4b

Dimensions

Main dimensions of plug-in modules in Form 2

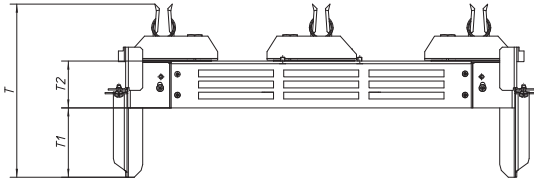
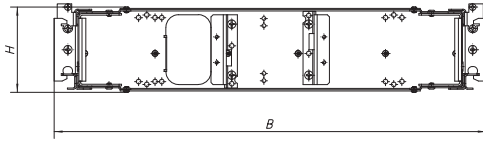

BS_Module_2b_Abmess

Type	B	H	T	T1	T2
NZM1 3p H100	507	100	203	81,5	55
NZM2 3p H150	507	150	202	81,5	55
NZM3 3p H200	507	200	206	8,5	125
Empty module H150	507	150	206	81,5	55
PKZ H100	507	100	203	81,5	55
NZM1 4p H150	507	150	203	81,5	55
NZM2 4p H200	507	200	203	81,5	55
NZM3 4p H250	507	250	206	8,5	125
Empty module H250	507	250	203	81,5	55

Main dimensions of plug-in modules in Form 4

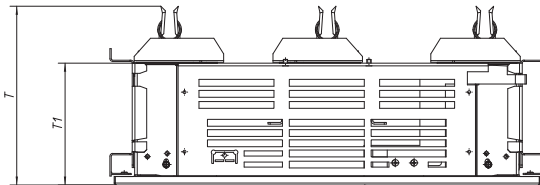
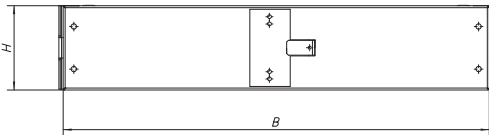

BS_Module_4b_Abmess

Type	B	H	T	T1
NZM1 3p H100	500	99	210	143
NZM2 3p H150	500	149	210	143
NZM3 3p H200	500	199	213	140
Empty module H150	500	149	210	142
PKZ H150	500	149	210	143
NZM1 4p H150	500	149	210	142
NZM2 4p H200	500	199	210	143
NZM3 4p H250	500	249	213	140
Empty module H250	500	249	210	143

XR Outgoing sections for switch fuse units

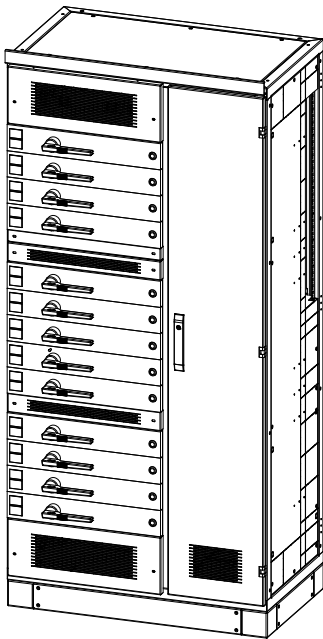

XE_Kat_SASIL_13-17

1000/1200

Section widths of 1000 and 1200 mm, (horizontal installation)

Section widths of 600, 800 and 1000 mm, (vertical installation) internal separation Form 4

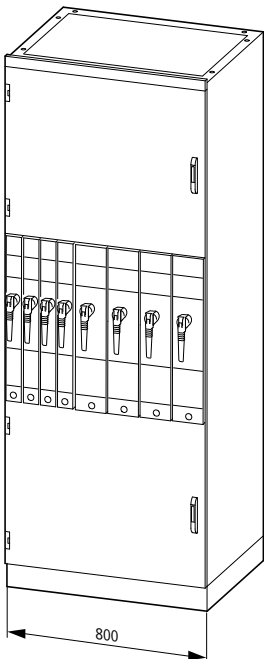

00161004_0

600/800/1000

Fuse strips can only be used with rear-mounted busbars. Please respect the max. current carrying capacity of the fuse strips depending on the ambient temperature, the degree of protection and the number of fuse strips per section in accordance with the xEnergy technical data.

Important rules for SASIL plus project planning

- Place switch fuse units evenly over the entire height of the cabinet
- Place large sizes at the bottom, small ones at the top! Thermal effect!
- Arrange sizes NH00-2 in blocks of 300mm, then leave at least 1 section of 75 mm for ventilation purposes!
- With size NH3 leave 1 section for ventilation purposes both above and below!
- No cross-partitioning in the switchgear area!
- Leave spare areas evenly placed over the entire cabinet height!
- Applying the full rated current is possible for a short while (15-30min). Please respect the rated diversity factors when under permanent load.
- If possible provide for ventilation of the top (max. IP31)!
- Arrangement of busbar supports
 - For size 00 above or below the fuse strips
 - For size 1 between the units
 - For sizes 2, 3 between the units or at the center behind the unit
- Center-to-center distance between busbar supports should be able to be divided by 150 mm (where necessary use another busbar support!!) Most important for smooth mounting of busbar covers!

for switch fuse units SASIL plus type, Jean Müller/ABB Slim-Line

- with double break feature
- in **vertical** and **horizontal** mounting position (Jean Müller)

Switchgear area:

- **Operation** of the switchgear **from outside** or **behind the door**
- Connection of the switch fuse strips on the incoming side to a vertically arranged dropper bar system, optionally available with plug-in module technology and protected against accidental contact
- Dropper bars provide access from the front over the entire height

Dropper bars:

- Center-to-center distance between phases 185 mm
- Rated current up to 1600 A
- Rated short-time withstand current I_{CW}

Busbar I_e A	Busbar cross-section L1, L2, L3, full N mm ²	Max. center-to-center distance of busbars in mm for I_{CW} (1s)		
		45 kA	50 kA	65 kA
800	1 x 40 x 10	600	600	-
1000	1 x 60 x 10	600	600	600
1250	1 x 80 x 10	750	750	600
1600	1 x 100 x 10	750	750	750

Cable connection area:

- Cable connection is implemented on the right side of the distributor section, outgoing cables can be introduced from above or below
- Connections of the fuse strips can optionally be covered with cable barriers for protection against accidental contact.
- Cable strain relief rails assure secure guidance for the outgoing cables
- The connection area is accessible via a separate door to the cable connection area and can be sealed off from the busbar and switchgear area.
- Vertical PE, N or PEN rails are installed in the cable connection area and can be equipped with terminations for every outgoing cable.

Type	I_e up to A	Size mm	Number per section
SASIL00	160	50	max. 24
SASIL1	250	75	max. 16
SASIL2	400	150	max. 8
SASIL3	630	150	max. 8

Vertical installation:

- Connection of the switch fuse strips on the incoming side to a vertically arranged dropper bar system
- Cable connection is implemented from the top or bottom
- The connection area is accessible via a separate door to the cable connection area
- Areas not used for cable insertion can be used for additional equipment, e.g. for controlgear
- **Operation** of the switchgear **from outside**

Type	I_e up to A	Size mm
SASIL00	160	50
SASIL1	250	75
SASIL2	400	150
SASIL3	630	150

Section width mm	Max. installation space mm
600	500
800	700
1000	900

XR Outgoing sections for switch fuse units - Dimensions

XF section with incorporation of SASIL switch fuse units, horizontal
XSMSHD...

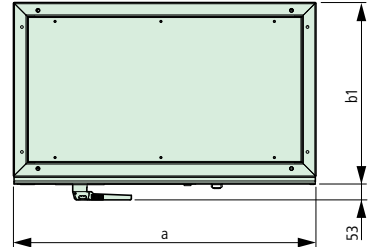
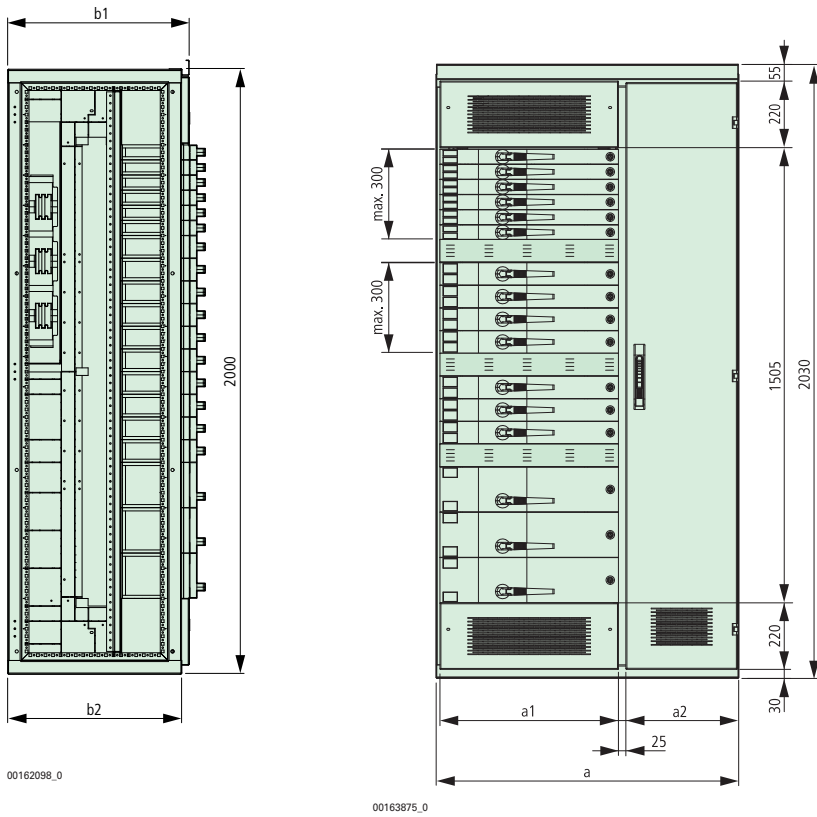

b1	b2
600	575
800	775

a	a1	a2
1000	590	369
1200	590	569

XF section with incorporation of dropper bars for SASIL switch fuse units, vertical
XDSSV...

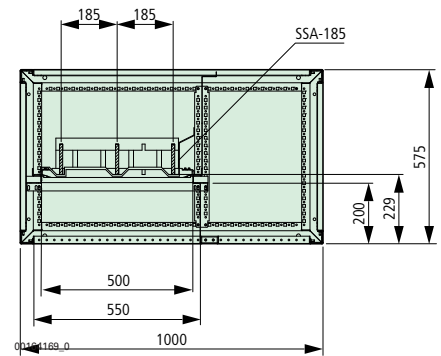
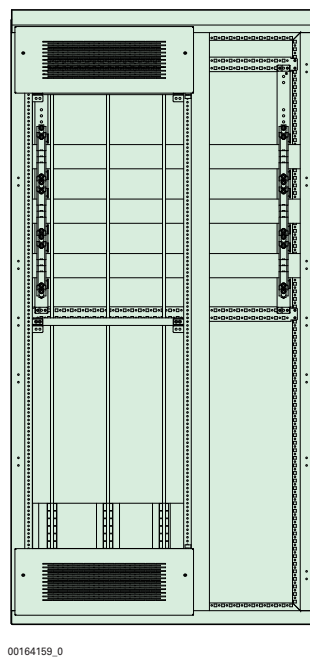
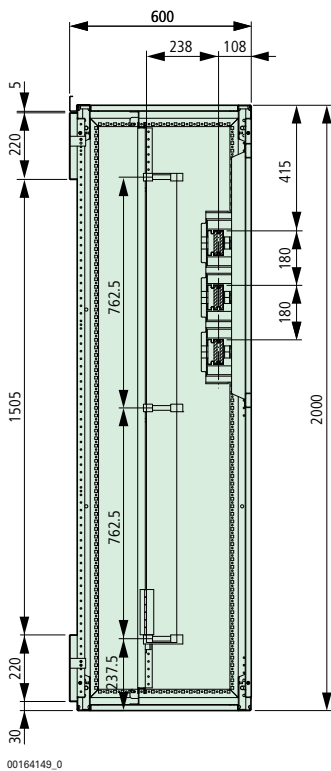

XR Outgoing sections for switch fuse units - Dimensions

XF section with incorporation of SASIL switch fuse units, vertical
XSMSV...08

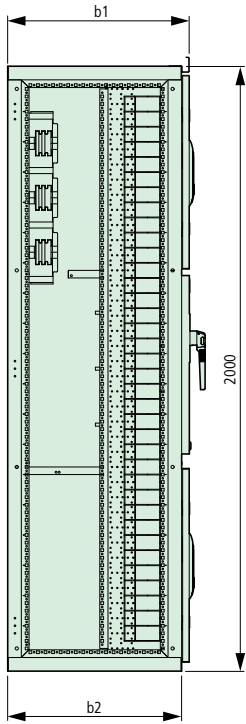

00162349_0

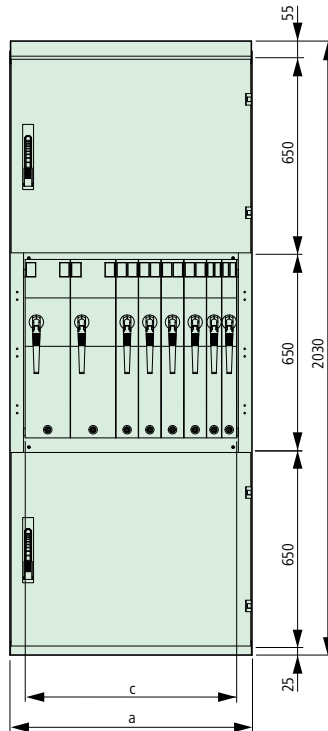

00162359_0

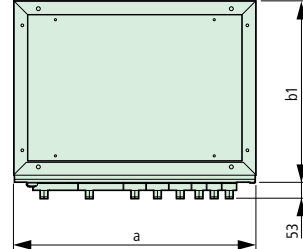

00162379_0

b1	b2
600	575
800	775

a	c
600	500
800	700
1000	900

XW Outgoing sections in fully withdrawable design

Functional areas



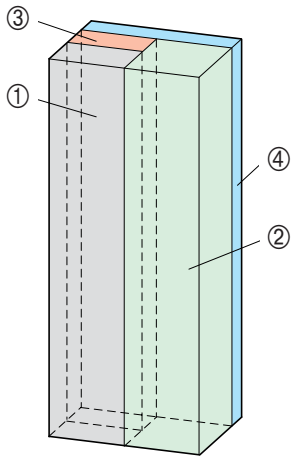

Busbar rear-mounted

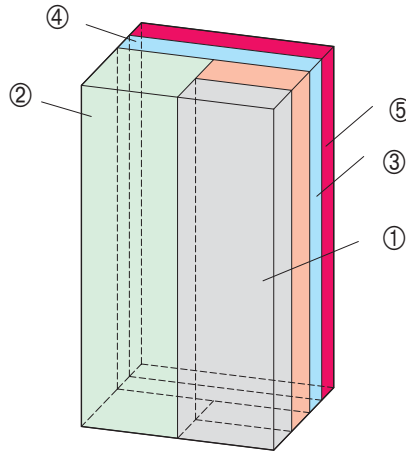

00156267_0



Kat_5000_funkts_r

- | | | |
|--|---|---|
|  1 Switchgear area |  3 Dropper bars |  5 additional main busbar section for 5000 A |
|  2 Cable connection area |  4 Main busbars | |

Outgoing sections for Motor Control Centers in withdrawable design

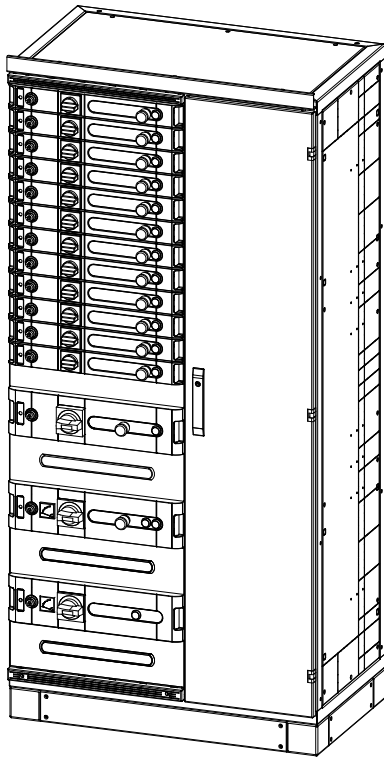

ANS-MCC-Katalog

Heights and versions of the withdrawable design:

Configuration as power outgoer, direct starter, reverse starter, star-triangle starter

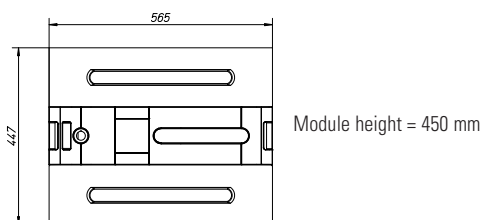
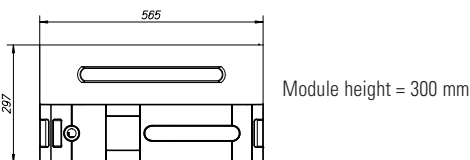
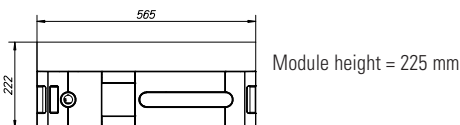
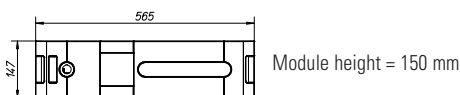
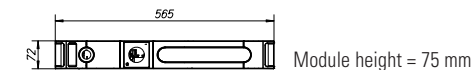

xE_MCC_2

- in the widths of 1000 and 1200 mm
- in section depths of 600, 800 and 1000 mm
- 3 or 4 poles
- rated current of dropper bars $I_n=1000$ or 2000 A / 3 or 4 poles
- max. short-circuit current $I_{CW}=80$ kA
- IP31/55
- shelf-boards can be individually mounted in height, depending on the size of the modules
- max. height of the dropper bar available for equipment = 1875 mm
- cable connection area is fully sealed off from the switchgear area, main busbar area and dropper bar area
- dropper bar is fully sealed off at the front thanks to self-closing shutters
- drawers available:
 - power outgoers up to 630 A
 - direct starters from 0.06-132 kW
 - reverse starters from 0.06-132 kW
 - star-triangle starters from 5.5-110 kW
- outgoers from 132 to 250 kW are executed as fixed design solutions

Switchgear area:

- max. height of switchgear area available for equipment = 1875 mm
- connection of modules (main/control circuit) both on the incoming and outgoing side is done on plug-type contact blocks. The outgoing plug-type contact block is mounted in the correct current rating on the shelf-board, which is then inserted into the switchgear area and fixed at the correct height.

Dropper bars:

- center-to-center distance between phases 60 mm
- rated current I_n 1000 and 2000 A
- rated short-time withstand current I_{CW} up to 80 kA

Cable connection area:

- cable connection has to be done on the right side of the distribution section, outgoing cables can be inserted either from the bottom or from the top
 - cable strain relief rails on the right side of the cabinet ensure a neat and safe guidance of outgoing cables
 - access to the cable connection area is provided through a separate door to the cable connection area which is fully sealed off from busbar areas and the switchgear area
 - vertical PE, N or PEN rails are mounted in the cable connection area and can be equipped with connections for any outgoing cable

Modules:

- Each module can be individually equipped, depending on whether you need a direct starter module or a reverse starter combination. Setup and dimensioning have to be done according to the enclosed instructions (AWA and BA).
- A detailed circuit / wiring plan provides information on the correct way of wiring the switchgear in the module
- The front covers of each module come with numerous punch holes and cut-outs so as to allow the individual integration options for all the required control units to be accommodated in each module
- Main-current contacting of the modules is done through plug-type contact terminals in line with the corresponding rating; these terminals are directly mounted on the shelf-board.
- Contacting the control lines is done via a plug-type terminal block which sticks out into the cable connection area. From there it is easy to do the control wiring in an extremely convenient way.

xEnergy Technical Guide

Outgoing sections for Motor Control Centers in withdrawable design

Overview of the different drawers listed according to module heights and performance (amperage)

Module heights mm	Drawers	Performance or amperage
75	FE3P	16A – 32A
	DOL	0,06kW – 15kW
	FR	0,06kW – 15kW
150	FE3P	20A – 200A
	FC3P	20A – 160A
	DOL	18,5kW – 55kW
	FR	18,5kW – 30kW
	SD	5,5kW – 15kW
225	FE4P	20A – 200A
	FC4P	20A – 160A
	DOL	55kW – 75kW
	FR	37kW – 75kW
	SD	18,5kW – 30kW
300	FE3P	200A – 300A
	FC3P	160A – 250A
	DOL	90kW – 110kW
	FR	90kW - 110kW
	SD	37kW – 75kW
450	FE3P	300A – 400A
	FE4P	200A – 400A
	FC4P	160A – 400A
	DOL	132kW – 200kW
	FR	132kW – 200kW
As of a height of 600 mm, it is only possible to create a set-up with fixed modules		
600	FE3P	400A – 630A
	FE4P	400A – 630A
	FC3P	400A – 630A
	FC4P	400A – 630A
	DOL	- 250kW
	SD	90kW – 200kW
750	FR	- 250kW
	SD	-250kW

Outgoing sections for Motor Control Centers in withdrawable design - Dimensions

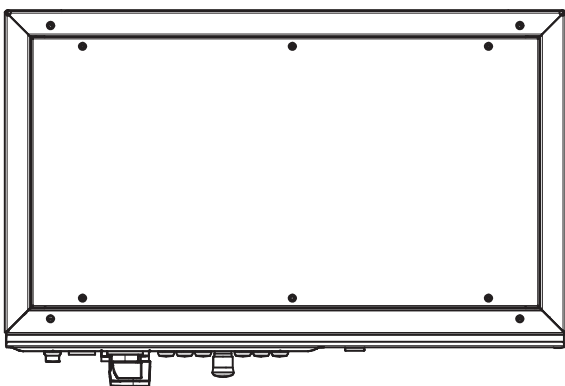
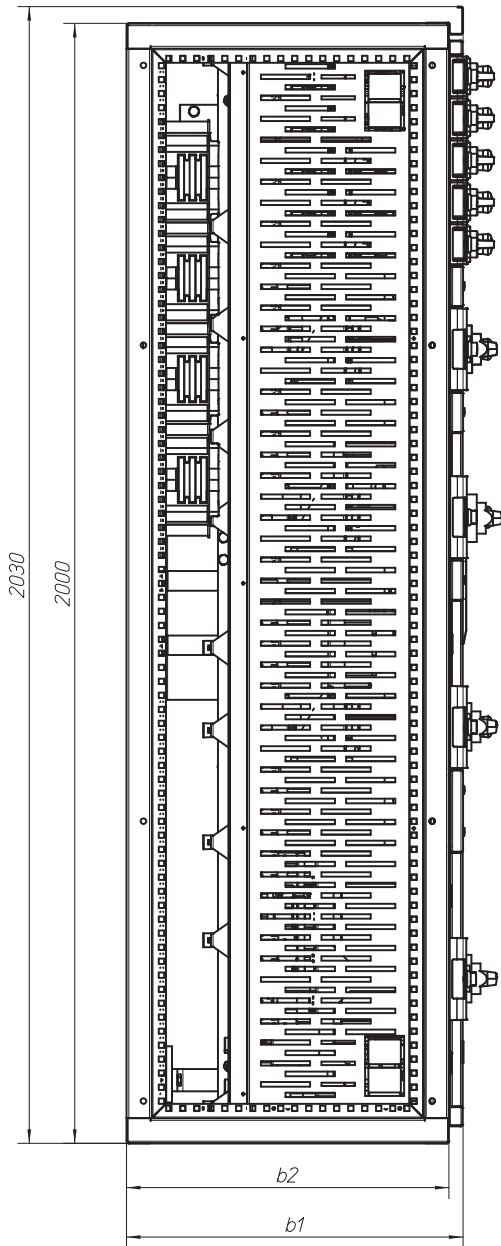
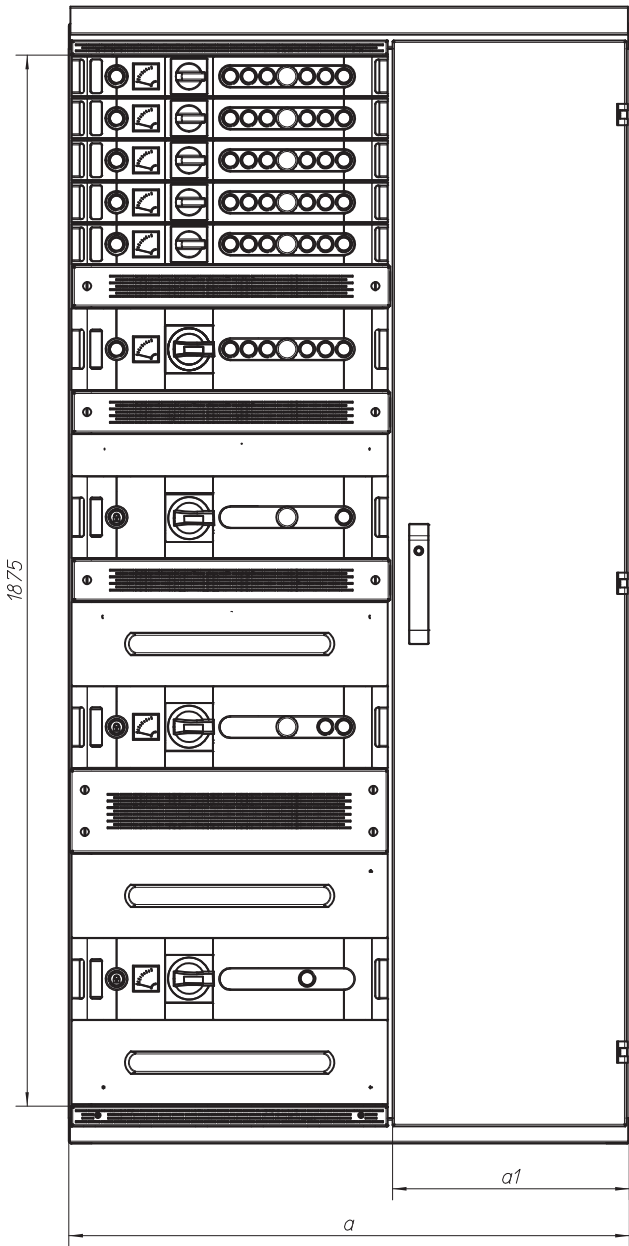

b1	b2
600	575
800	775

a1	a2
1000	425
1200	625

General Sections

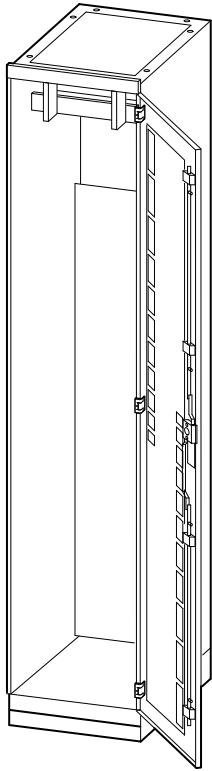

00163952_0

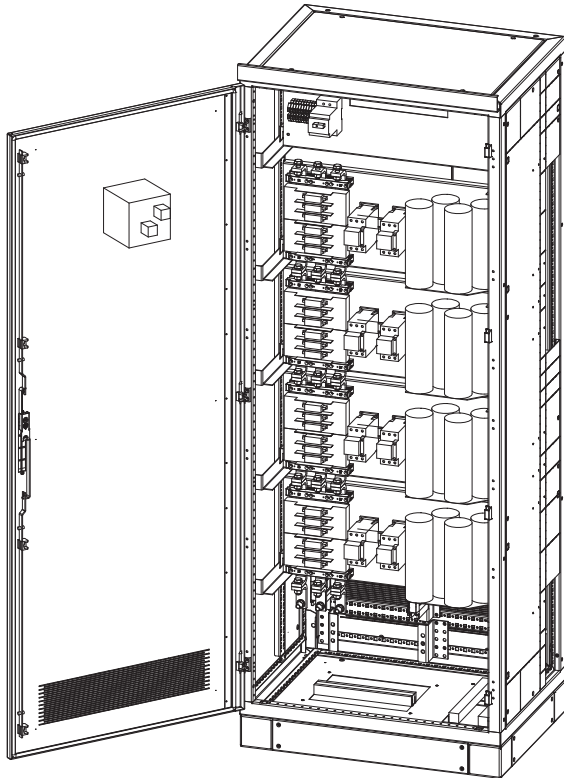

xE_Kompensation

- in the widths of 425,600,800,850,1000,1100,1200 and 1350 mm
- IP31/55
- with the main busbar at the top or rear, or without any main busbar as a control distribution unit
- with mounting plate(s) in one piece or split
- as a compensation distribution unit
- suitable for integrating xBoard Profi Plus, IVS, Profi Plus EP, SASY60i

Switchgear area:

- the switchgear area can be set up individually, according to customer specifications
- whether you use a control distribution board with a mounting plate or a mounting plate in combination with SASY60i as a power or motor-distribution board, or one of the different fitting systems such as xBoard Profi Plus, IVS, Profi Plus EP - we have the right solution for every application

Empty sections for universal applications

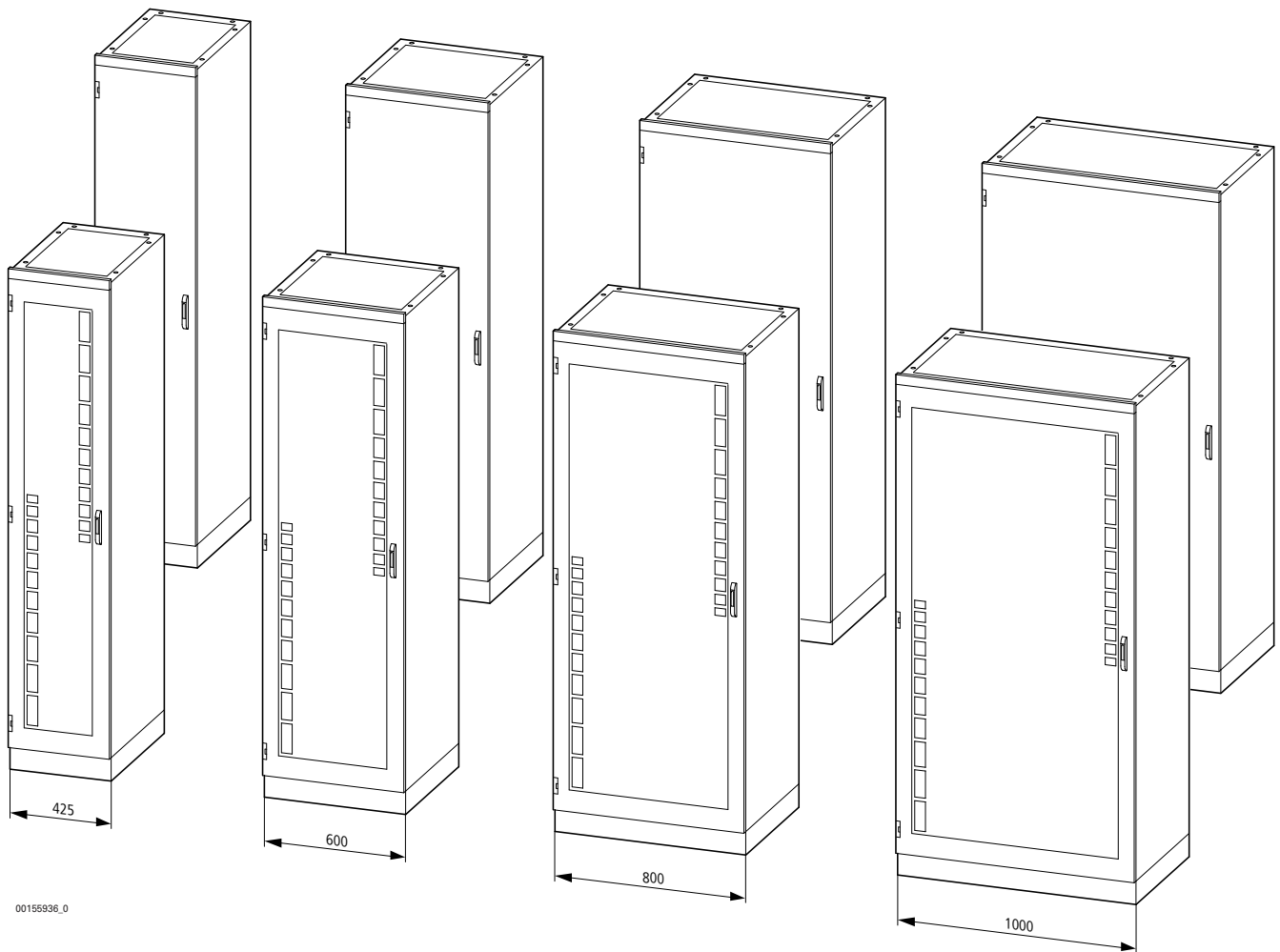

00155936_0

Universal empty sections for the following installation possibilities:

Installation distribution systems	e.g. with Eaton IVS	Product range catalogue IVS SK0207-1185 Power distribution systems or Electronic Catalogue
Switchgear adapter	e.g. with Eaton xStart	Main catalogue HPL0211, Industrial switchgear or Electronic Catalogue
Frequency converter	e.g. with Eaton DF51, DF6, DV51, DV6 and DV5/6	Main catalogue HPL0211, Automation systems and Drives or Electronic Catalogue
Soft starters	e.g. Eaton DS4, DM4 and DS6	Main catalogue HPL0211, Automation systems and Drives or Electronic Catalogue
Automation systems	e.g. with EatonPS4, PS416, XC100, XC200 ...	Main catalogue HPL0211, Automation systems and Drives or Electronic Catalogue
Large motor starters	e.g. with Eaton contactors up to 900 kW/400 V	Main catalogue HPL0211, Industrial switchgear or Electronic Catalogue
Power factor correction	e.g. with FRAKO, KBR	Chapter Power factor correction

With a front door as high as the cabinet, ventilated, closed or transparent, right or left-hinged

Planning tools

The right tool for every stage of your project

Eaton Engineering Tools support you in

- Network planning and calculation
- Preparing your offers
- Designing distribution systems
- Generating parts lists and ordering

Eaton xSpider

Proven functions for network planning and calculation

- Load flow and short-circuit calculation
- Dimensioning of the devices
- Selectivity calculation and graphic comparison
- Conformity to IEC 909 and IEC 60364 standards
- Automatic verification of data completeness

Expertise and experience

- xSpider simplifies and speeds up your job by relieving you from time-consuming routing tasks
- xSpider protects against planning errors in low-voltage networks

Functional and flexible

- easy generation of network drawings
- clearly structured database
- xSpider is the right tool for every stage of a project and for testing the existing networks

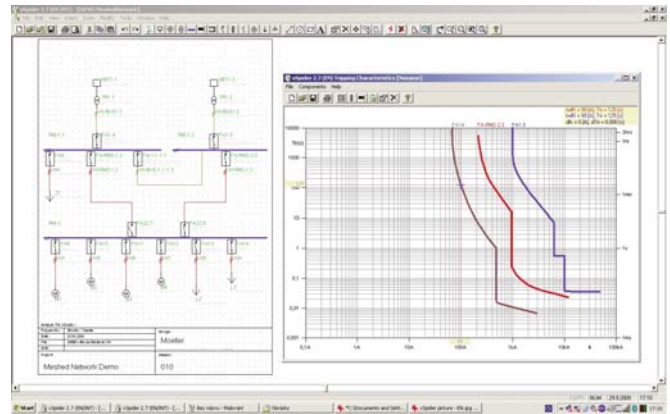

With xSpider you can plan low-voltage networks (meshed systems and radial networks) safely and without problems.

Eaton Configurator

User-friendly for the selection of xEnergy

- Windows-based dialogue guidance
- functional, self-explanatory design structure
- short familiarization time thanks to Look and Feel

Wide range of applications

- project administration and system structure
- a functions-guided system selection will automatically generate the suitable distributor
- generation of a parts list for devices, fitting kits and distributors
- generation of a front view for offers, individual adjustments through Drag and Drop

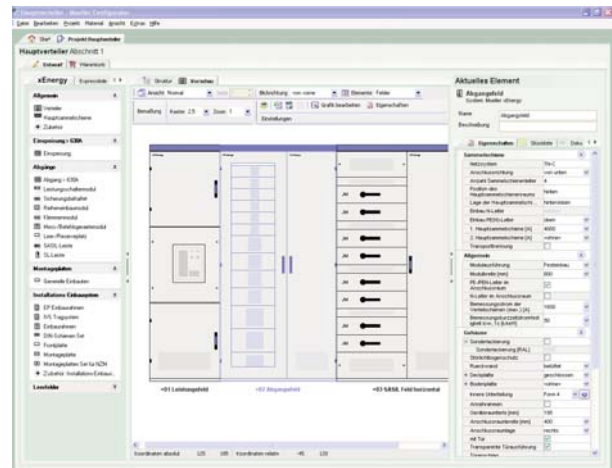

Eaton Configurator is the fastest selection tool for xEnergy.

CurveSelect

Characteristics program for short-circuit and overload protective devices

- CurveSelect makes it easy to display, compare and document characteristics
- CurveSelect is free of charge and allows the setting-specific and simultaneous display of tripping characteristics of several protective devices based on the same time and current standards. An analysis of the interaction of NZM and IZM circuit breakers, PKZ motor protectors, ZB motor-protective relays and MCBs as well as NH fuses gets significantly easier this way.

Use the following link to find the right Internet site:
www.moeller.net/de/products_solutions/power_distribution/power_communication/curve_program/index.jsp



Further information - Setup instructions for xEnergy

Operation and maintenance alleyways between switchgear assemblies

The minimum width for operation and maintenance gangways of switchgear assemblies is 700 mm, the minimum headroom under

the panelling is 2000 mm. If a lift truck is used for exchanging circuit breakers, gangway dimensions must be taken into account dur-

ing the design stage.

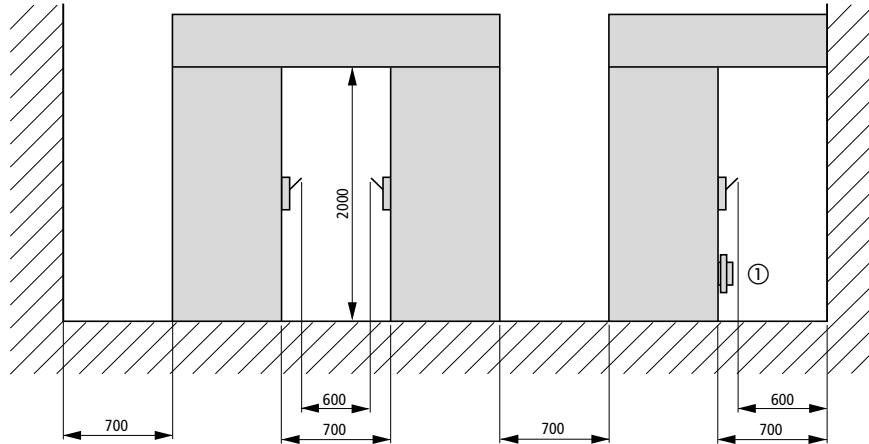

① drawer unit in disconnected position

For systems with a rated current of 5000 A at the main busbar (depth = 1000 mm), access from the rear is compulsory. There must be a

minimum clearance of 700 mm to the next wall or to the next cabinet in order to be able to ensure an uncomplicated setup of the sys-

tem and to allow for service jobs to be done in line with the regulations.

Doors of a switchgear assembly should be arranged in a way that they close in the direction of the emergency exit route. With a differ-

ent arrangement, a free minimum clearance of 500 mm must be provided for. If switchgear combinations are set up opposite

each other, it is not necessary to anticipate that the doors on both sides are open at the same time.

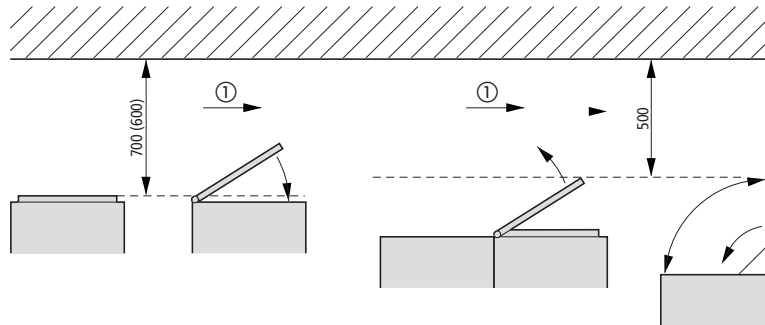

① Direction of the emergency exit route

Further information - Setup instructions for xEnergy

Bottom view of distribution sections

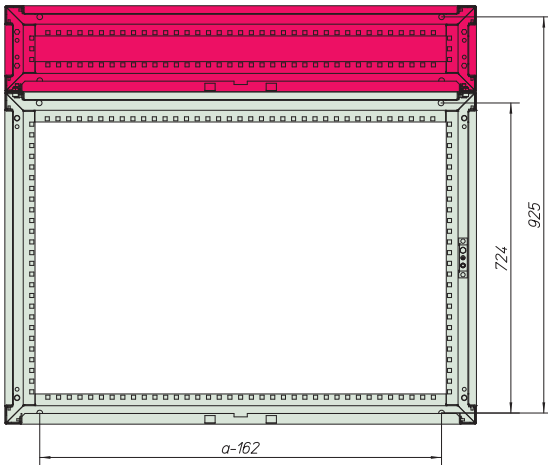

Bottom view of plinth

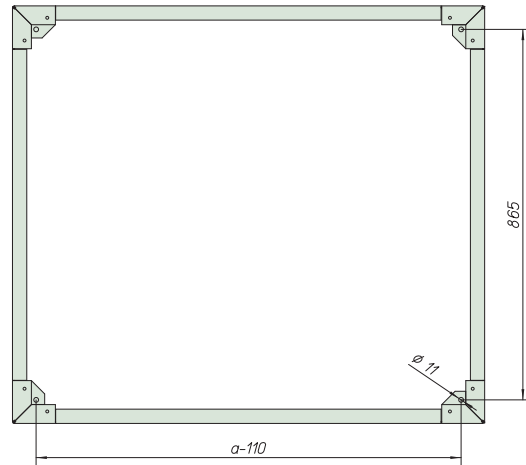

For 5000 A, the red-coloured parts are required in addition.

e.g.: a (section width) - 162 = distance between the holes in the plinth fixture

a = section width

Section width 425, 600, 800, 850, 1000, 1100, 1200 and 1350 mm

Section depth with section door 400, 600, 800 and 1000 (800 + 200) mm

Section depth without section door 375, 575, 775 and 975

Top view of setup (stand-alone)

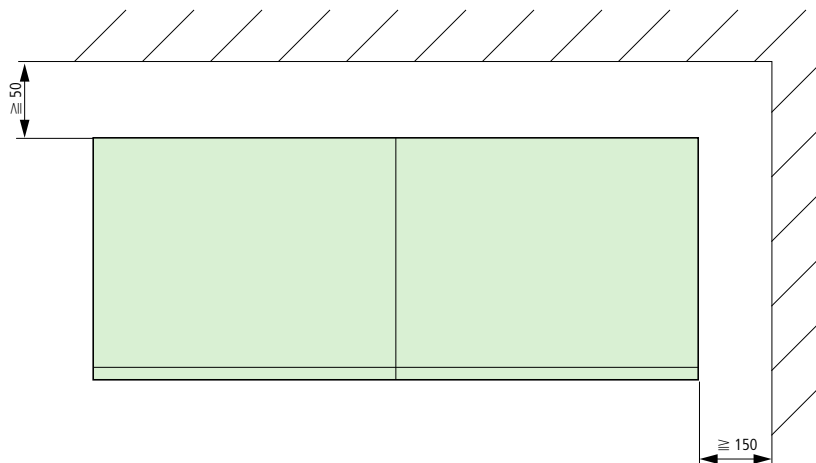

General overview - side view of a section

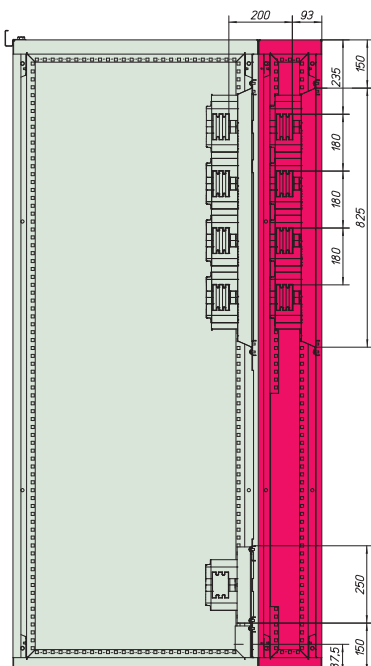

For 5000 A, the red-coloured parts are required in addition.

Further information - Passive Arc Fault Protection

In order to achieve passive arc fault protection, the following requirements must be respected:

- **Fix an arc fault damper**

Use a cover plate equipped with a damper that is fixed at the front through hinges and secured at the rear through PVC screws. The high pressure caused by an arc fault will destroy the PVC screws and release the damper so as to allow the hot gases to escape. Therefore, the hinges of the arc fault damper always need to be mounted at the front of the cabinet in order to ensure a maximum of protection against escaping gases for the people working there.

It is also necessary to pay attention to sufficient room height or other building-related superstructures on top of the switchboard cabinet to make sure the damper can fully open.

- **Replace the standard catch-hooks of the doors**

(Exception = doors to the cable connection area in the XF/XG/XW section, where a different type of catch-hooks is installed that you can continue to use without replacing them).

- **Do not use any doors, rear panels or front plates with ventilation slots**

in order to make sure that all of the gases that may develop will escape at the top.

Fix an arc fault damper

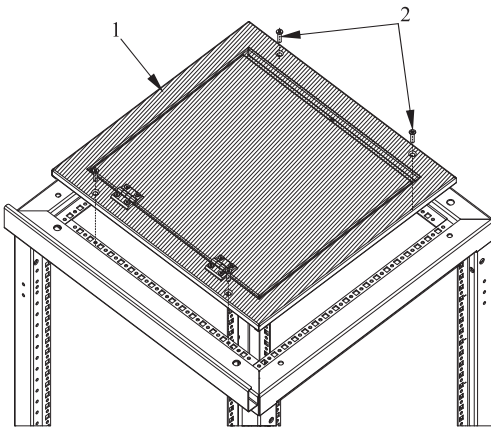

xE_Stoerlichtbogenklappe

Replace the catch-hooks

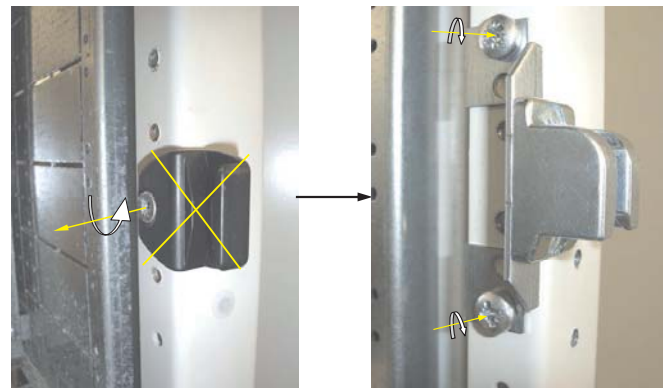

xE_Fanghaken

Rated voltage U_n (V)	Conditional short-circuit current I_{cc} (kA_{eff})	Time t (s)
440	65	0,3

Dimensions

Doors as high as the section

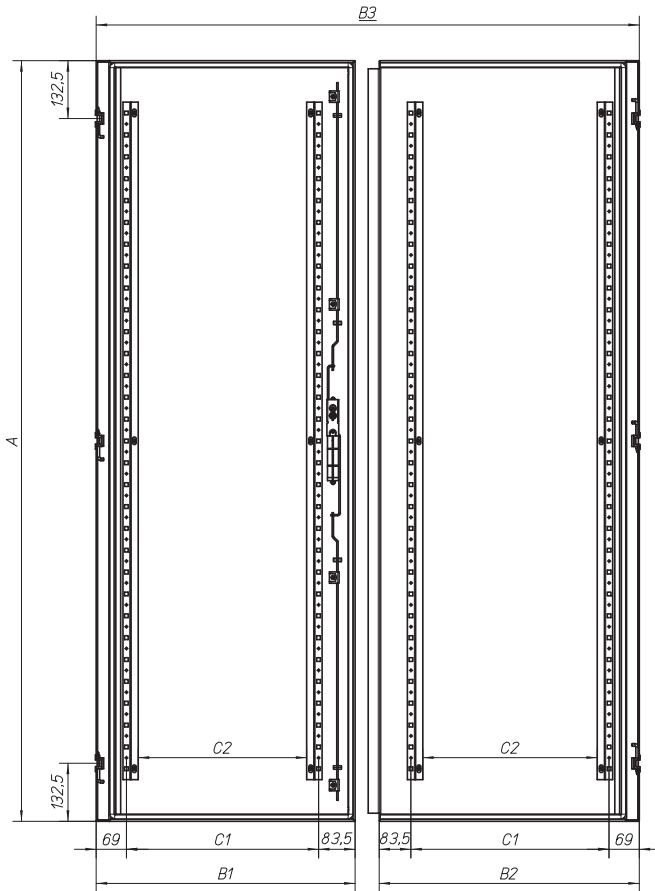

Mas_XSDMC

Door to switchgear area - height 640 mm (1 third of the door)

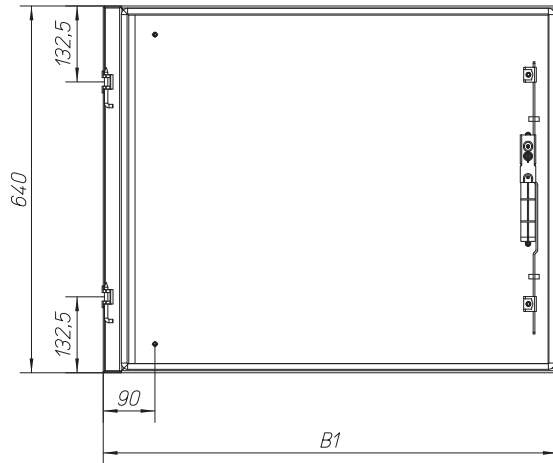

Mas_XE_Dritteltuer

Width	B1
425	425
600	600
800	800
1000	1000
1100	1100
1200	1200

Width	B1	B2	B3	C1	C2
425	417	-	-	264,5	210,5
600	592	-	-	439,5	385,5
800	792	-	-	639,5	585,5
850	842	-	-	689,5	635,5
1000	992	-	-	839,5	785,5
1000	492	495	992	339,5	285,5
1100	542	545	1092	389,5	335,5
1200	592	595	1192	439,5	385,5
1350	667	670	1342	514,5	460,5

Height	A
2000	1940

Dimensions

Door to switchgear area - split in the middle, for section width 1350 mm

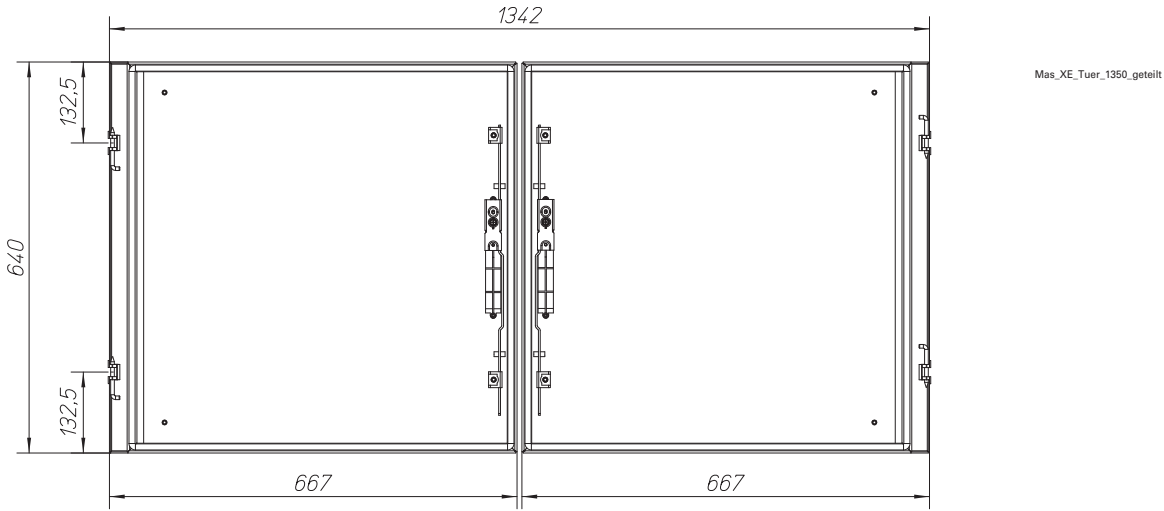

Door to switchgear area for main busbar area at the top

Only available in section width 800 mm

Possible solutions:

Two doors in one part, in section width

Door H-290mm = Main busbar area

Door H-340mm = Switchgear area

One door in one part, in section width

One pair of doors, both together in section width

Door H-290mm = Main busbar area

Door H-340mm = Switchgear area

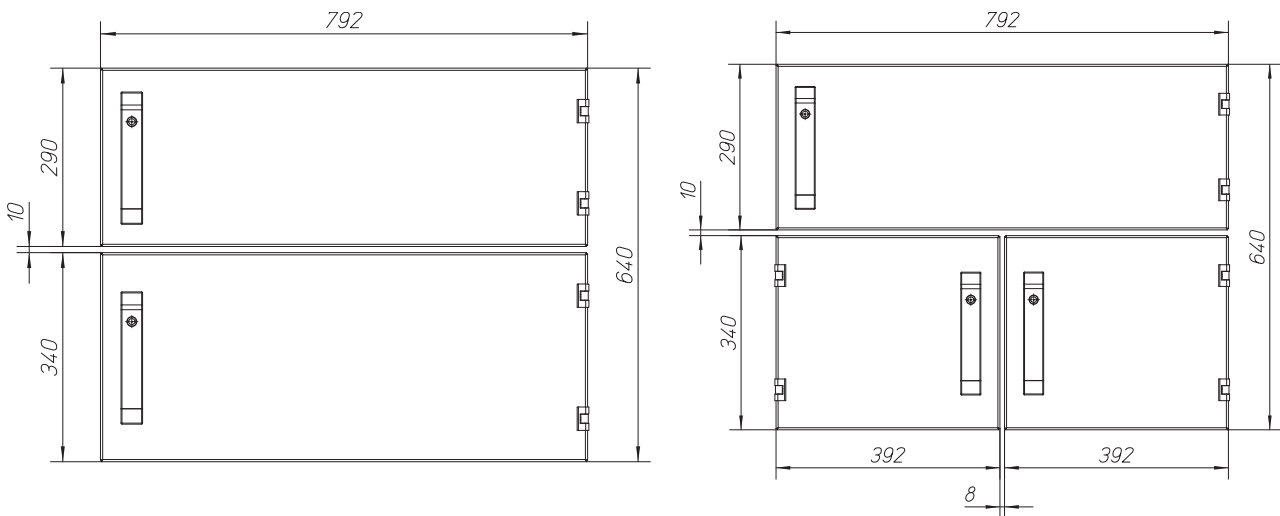

Detail drawings of doors to the switchgear area

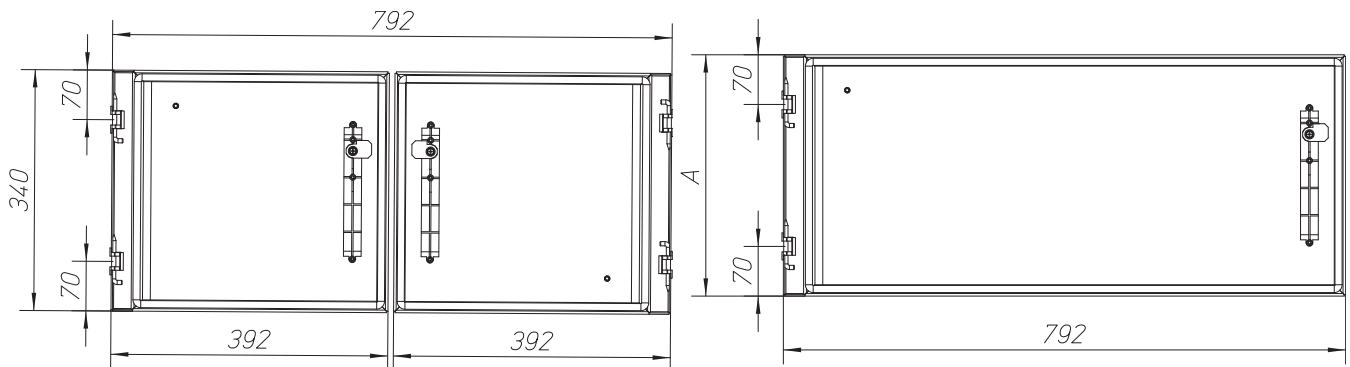

Mas_XE_Tuer_Detail_1

Height	A
290	
340	

Mas_XE_Tuer_Detail_2

Dimensions

Template for holes to accommodate the hinges at the frame post

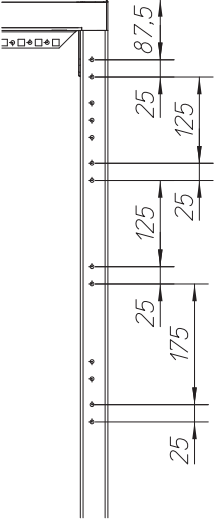

Dimensions

XP section with incorporation of IZM circuit breakers XSMIB20

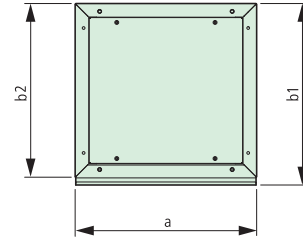
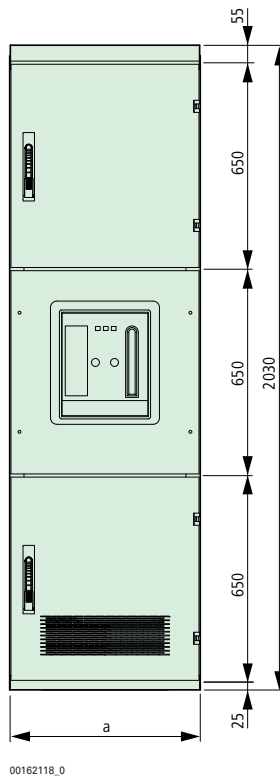
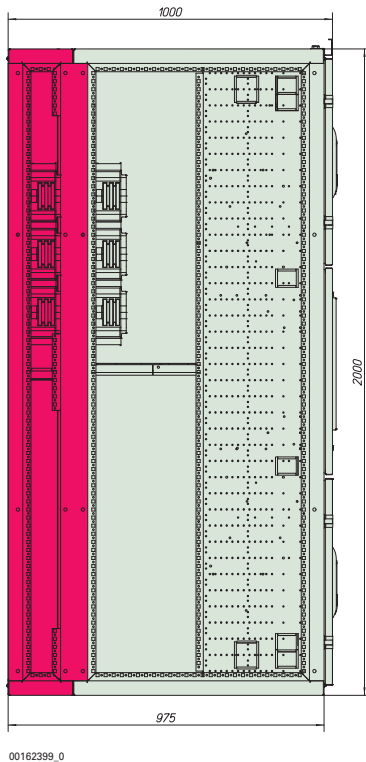

00162219_0

b1	b2
600	575
800	775
1000 (800+200)	975

a
425
600
800
850
1000
1100
1200
1350

For 5000 A, the red-coloured parts are required in addition.

XSFDR Green/Blue Design Strip

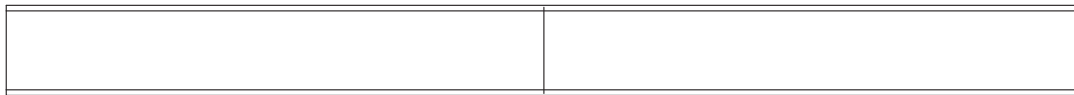
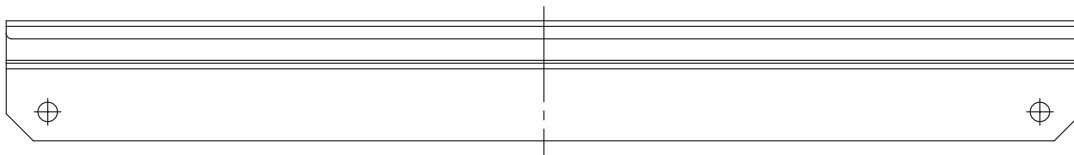

Mas_SVTL_GBS

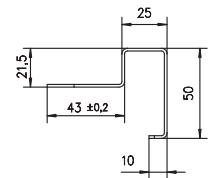



Eaton Partner program

The key to your success with xEnergy switchboard systems is the Eaton Partner program. Joining the program is well worth it: Not only will you receive a wealth of insider information, you will also be the first to get informed about facts and innovations regarding xEnergy.

A few seconds after you register under www.xenergy-partner.de you will become an xEnergy Partner Net will welcome you personally and all the benefits of the Eaton Partner program will instantly be available to you.

For more information visit us at www.xenergy-partner.com



Benefits

- Listing as a Licensed Partner on the Eaton website
- Access to BAs, AWAs (building and assembly instructions), Configurator, certificates and technical data sheets
- Continuously up-dated product information
- Software downloads
- Installation instructions
- Information material for your customers, such as catalogues and flyers
- Certificates of conformity and guidelines regarding IEC standards

Eaton's Electrical Sector is a global leader in power distribution, power quality, control and automation, and monitoring products. When combined with Eaton's full-scale engineering services, these products provide customer-driven PowerChain™ solutions to serve the power system needs of the data center, industrial, institutional, public sector, utility, commercial, residential, IT, mission critical, alternative energy and OEM markets worldwide.

PowerChain solutions help enterprises achieve sustainable and competitive advantages through proactive management of the power system as a strategic, integrated asset throughout its life cycle, resulting in enhanced safety, greater reliability and energy efficiency.

For more information, visit www.eaton.com/electrical.

Published by: Eaton GmbH
Scheydgasse 42
1215 Vienna

© 2011 by Eaton GmbH, Austria
Subject to technical modifications. No responsibility is taken for misprints or errata.
Printed in Austria (06/11)
Graphic design: SRA, Werbeweber, Schrems
Print: Druckerei Rabl, Schrems
PU01416001Z-EN
Article No. 158487

The products presented are part of the comprehensive Eaton offer.
For more information, please contact your Eaton consultant.

www.eaton.com