

# Successful implementation of the ErP Directive

Reducing losses with speed control

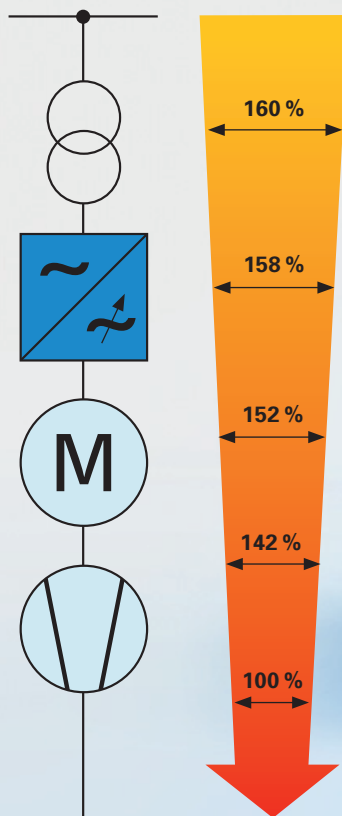

**White Paper**  
Dipl.-Ing. Heribert Joachim  
2nd edition, 2014

# Energy efficiency in industrial application – leveraging potential savings in electrical drive engineering

## Introduction

Energy efficiency is a hot topic. In recent years, politics and business have made every endeavour to save energy in production systems and reduce CO<sub>2</sub> emissions in the industrial sector. Remarkable success has been achieved in many areas, but it is still far too soon for us to rest on our laurels. There is still great energy-saving potential, particularly in electrical drive engineering. This potential can be most effectively exploited in the intelligent use of automation technology combined with motor starters or frequency drives. The key factor here is selecting the right solution for each application.

German industry is responsible for around 30% of all final energy consumption in the country (see fig. 1). Two thirds of this figure are used for process heat. Mechanical energy makes up a quarter of consumption, while room heat is responsible for only a minor share of total consumption<sup>1</sup>. 54% of final energy demand in industry comes from the goods-producing industry<sup>2</sup>. According to the German Electrical and Electronic Manufacturers' Association (ZVEI), energy savings of 10% to 25% could be achieved in the plants of the German process and manufacturing industries alone by using more efficient automation technology, equating to 88 billion kilowatt hours of energy equivalents. This would save up to 7 billion in annual energy costs.<sup>3</sup>

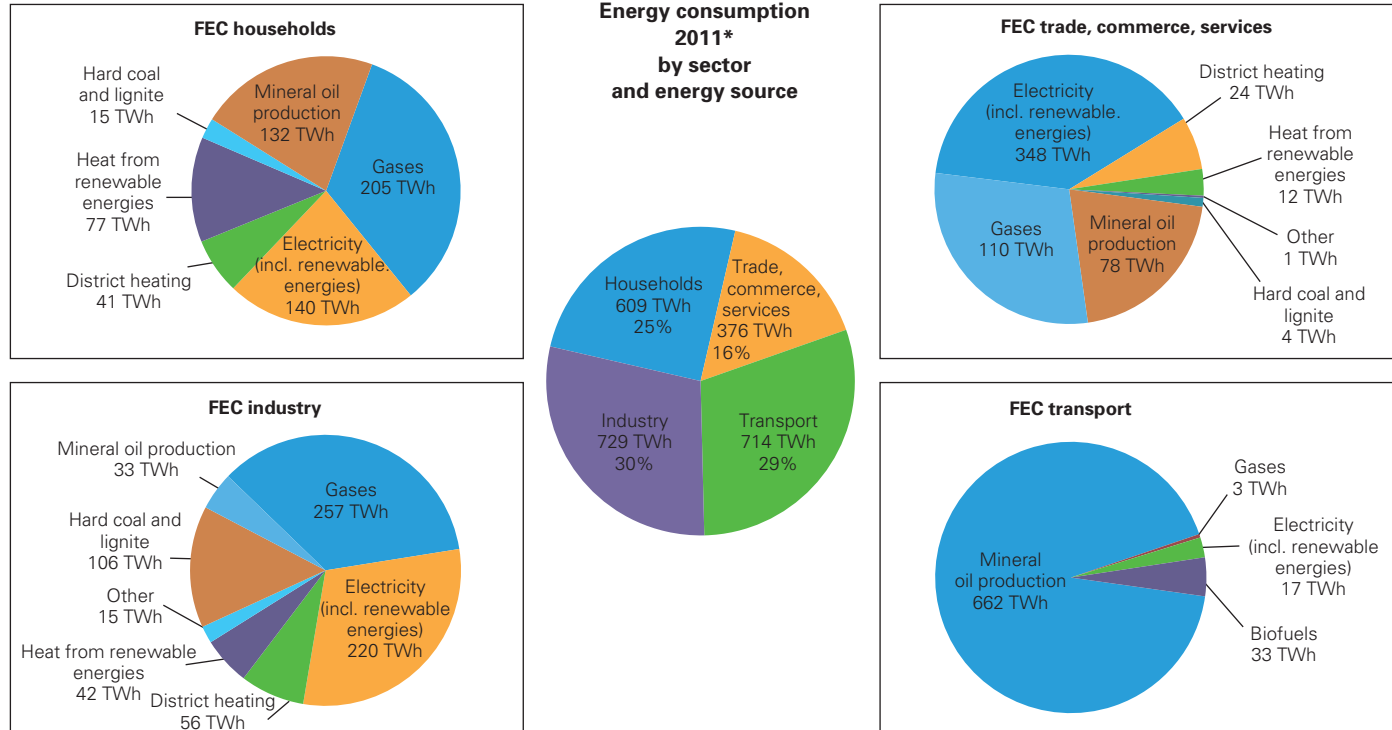

Fig. 1 Energy consumption in Germany (2011) by sector and energy source, source: Arbeitsgemeinschaft Energiebilanzen, Federal Environment Agency

1 Federal Environment Agency, energy consumption by source and sector, March 2013, <http://www.umweltbundesamt-daten-zur-umwelt.de/umweltdaten/public/theme.do?nodent=5978> [in German]  
 2 VDMA / Roland Berger: Der Beitrag des Maschinen- und Anlagenbaus zur Energieeffizienz, 2009  
 3 ZVEI: Automation, Mit Hightech für Umwelt- und Klimaschutz – Automation: Wir machen's energieeffizient!, 2010

Industrial automation also has huge potential when it comes to greenhouse gases. 37% (378 million tons of CO<sub>2</sub>e, CO<sub>2</sub>e = CO<sub>2</sub> equivalent) of all greenhouse gas emissions in Germany (1,025 million tons of CO<sub>2</sub>e) originate in the industrial sector, and this figure is expected to rise sharply in the next 20 years. It is, however, still possible to apply the brakes. An increased use of intelligent environmental technologies, chief among them automation solutions, could slow this progression and in part even reverse it<sup>4</sup>. In industry, greenhouse gas savings of 43 million CO<sub>2</sub> equivalents could be achieved (approx. 11% of all emission in the industrial sector). This equates to the annual CO<sub>2</sub> emissions of some seven major coal-fired power stations (2,000 MW each)<sup>5</sup>.

Within industrial manufacturing, electrical drives account for the lion's share of around two thirds of electrical energy consumption<sup>6</sup>. Increasing efficiency by the use of the right drive engineering therefore has a special role to play. In Germany alone, the Federal Environment Agency estimates that more efficient drive engineering, including intelligent automation solutions, could reduce consumption by some 27 billion kilowatts to 2020, in the process preventing 16 million tons of CO<sub>2</sub> emissions<sup>7</sup>. The savings potential in electrical drive engineering becomes even more apparent in view of the fact that energy costs make up by far the largest part of an electric motor's overall life cycle costs (see fig. 2).

On the basis of these findings, the European Union has launched a number of initiatives to promote ecodesign in products. The core of these proposals is the ErP Directive 2009/125/EC for "Energy related Products"<sup>8</sup>, which replaces and expands the scope of ErP Directive 2005/32/EC<sup>9</sup>. It creates a framework for defining common ecodesign requirements for products which consume energy and sets out criteria which affected products must meet to be eligible for operation in Europe. The requirements relating to individual product groups are set out in separate implementing guidelines, e.g. Regulation EC 640/2009 for electric motors<sup>10</sup>.

But this raises a number of questions: what exactly are the new requirements for electric motors, and which types are affected? How can companies most effectively leverage the savings potentials in electrical drive engineering? Which automation solution is best suited to which application? What implementation strategies exist? How much investment is required for technical modernization? This paper aims to offer answers to these questions and guide machinery engineers, control cabinet builders and plant operators in using suitable automation solutions to improve the energy efficiency and environmental compatibility of their manufacturing processes in electrical drive engineering.

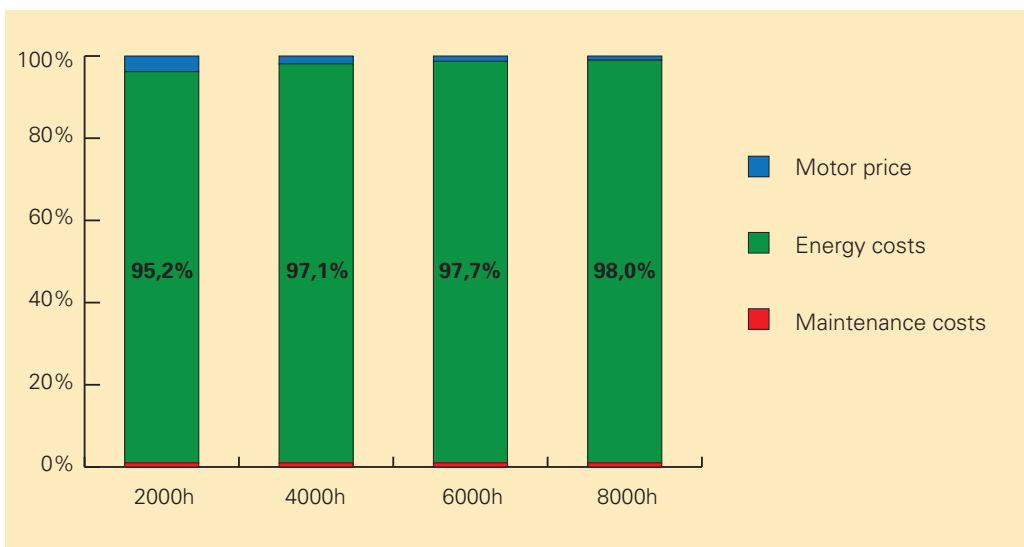

Fig. 2: Life cycle costs (excl. installation and disposal costs) of an 11 kW motor with a lifetime of 15 years (or, alternatively, oder ZVEI Motors and closed-loop controlled drives, page 14), Source: diam-consult\*

\* From Almeida, A.T. Ferreira, Fong, J., Fonseca, P., EUP Lot 11 Motors; ISR-University of Coimbra, February 2008

4 ZVEI, based on McKinsey & Company, Inc. "Costs and Potentials of Greenhouse Gas Abatement in Germany", industry report, 2007  
 5 ZVEI, Measuring Technology and Process Automation Division, in: ZVEI: Automation, with high-tech for environmental and climate protection – Automation: We make it energy efficient!, 2010  
 6 ZVEI, Motors and closed-loop controlled drives – standards and legal requirements for low voltage three-phase motors, 2013 [in German]  
 7 Federal Environment Agency, Press Information No. 53/2009, Energy efficiency in electric motors, 2009 <http://www.umweltbundesamt.de/en/press/pressinformation/energy-efficiency-in-electric-motors>

8 Directive 2009/125/EC establishing a framework for the setting of ecodesign requirements for energy-related products  
 9 Directive 2005/32/EC establishing a framework for the setting of ecodesign requirements for energy-using products  
 10 Commission Regulation (EC) No. 640/2009 of July 22, 2009, implementing Directive 2005/32/EC of the European Parliament and of the Council with require to ecodesign requirements for electric motors

## Legal frameworks

EC Directives are legally binding on all member states of the European Union and come into force shortly after publication in the EU's Official Journal. The ErP Directive 2009/125/EC creates a framework for defining common ecodesign requirements for energy-related products. These include electric motor systems and HVAC applications such as instant water heaters, hot-water heaters, commercial refrigerators and freezing plants, air-conditioning systems, pumps, fans and compressors.

Regulation EC 640/2009 defines compulsory minimum efficiency classes for various efficiency levels of three-phase low voltage asynchronous motors (for application areas, see fig. 3). This type of motor is widespread in industry and in 2005 accounted for almost 90% of power consumption by electric motors in the 27 member states of the EU<sup>11</sup>. In this context, the former voluntary EFF classes issued by the European Committee of Manufacturers of Electrical Machines and Power Electronics (CEMEP) were replaced by International Efficiency (IE) classes as set out in IEC 60034-30 for induction motors. They are IE1 (standard efficiency), IE2 (high efficiency) and IE3 (premium efficiency). The efficiency rating is now calculated using new methods (as per IEC 60034-2-1:2007) as follows:

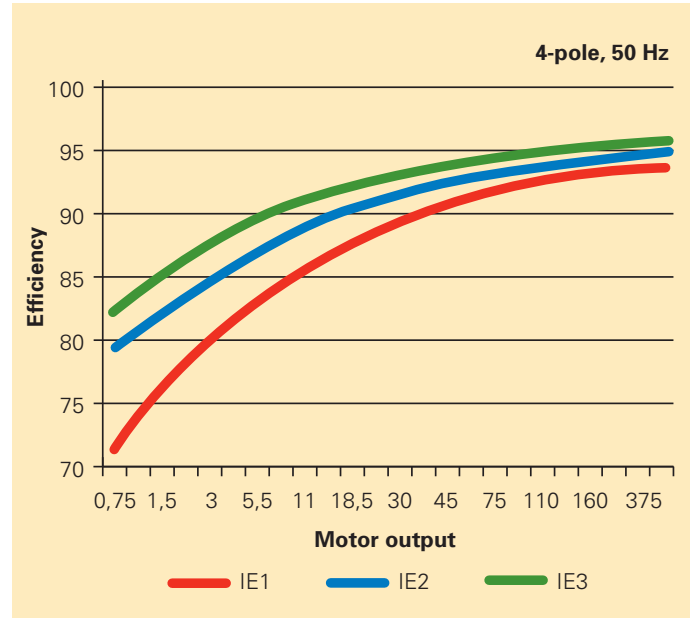

Fig. 4: Global efficiency curves (IE code) of standard asynchronous motors, source: ZVEI

Which motor falls within which area of validity	Standard IEC 60034-30:2008 Class names: IE1, IE2, IE3	ErP Directive/Regulation 640/2009 Minimum legal requirement
<b>1</b> Standard three-phase asynchronous motor 0.75–375 kW 2, 4, 6-pole, continuous duty S1 <i>(Note: also applies if the motor is installed in a machine)</i>	Yes Note: additional operating mode S3 (duty cycle ≥ 80 %)	Yes
<b>2</b> Standard three-phase asynchronous motor with auxiliary attachments (shaft seals, anti-reversing devices, rotary encoders etc.) 0.75–375 kW 2, 4, 6-pole, continuous duty S1 <i>(Note: efficiency measurement without auxiliary attachments)</i>	Yes Note: additional operating mode S3 (duty cycle ≥ 80 %)	Yes
<b>3</b> Geared motor	Yes	Yes
<b>4</b> Explosion-proof motor	Yes	No
<b>5</b> Brake motor A motor with an electromechanical brake device which engages directly with the drive shaft without coupling.	Yes	No
<b>6</b> Motors fully integrated within a machine (e.g. pumps, fans, gearboxes and compressors) and whose efficiency cannot be measured independently of this machine.	No	No
<b>7</b> Other motor types (e.g. permanent magnet motors, pole-changing motors, motors for switching mode, e.g. servomotors)	No	No

Fig. 3: Comparison of areas of validity in the IEC/EU Motor Directive, source: ZVEI

<sup>11</sup> Federal Environment Agency, Press Information No. 53/2009, Energy efficiency in electric motors, 2009

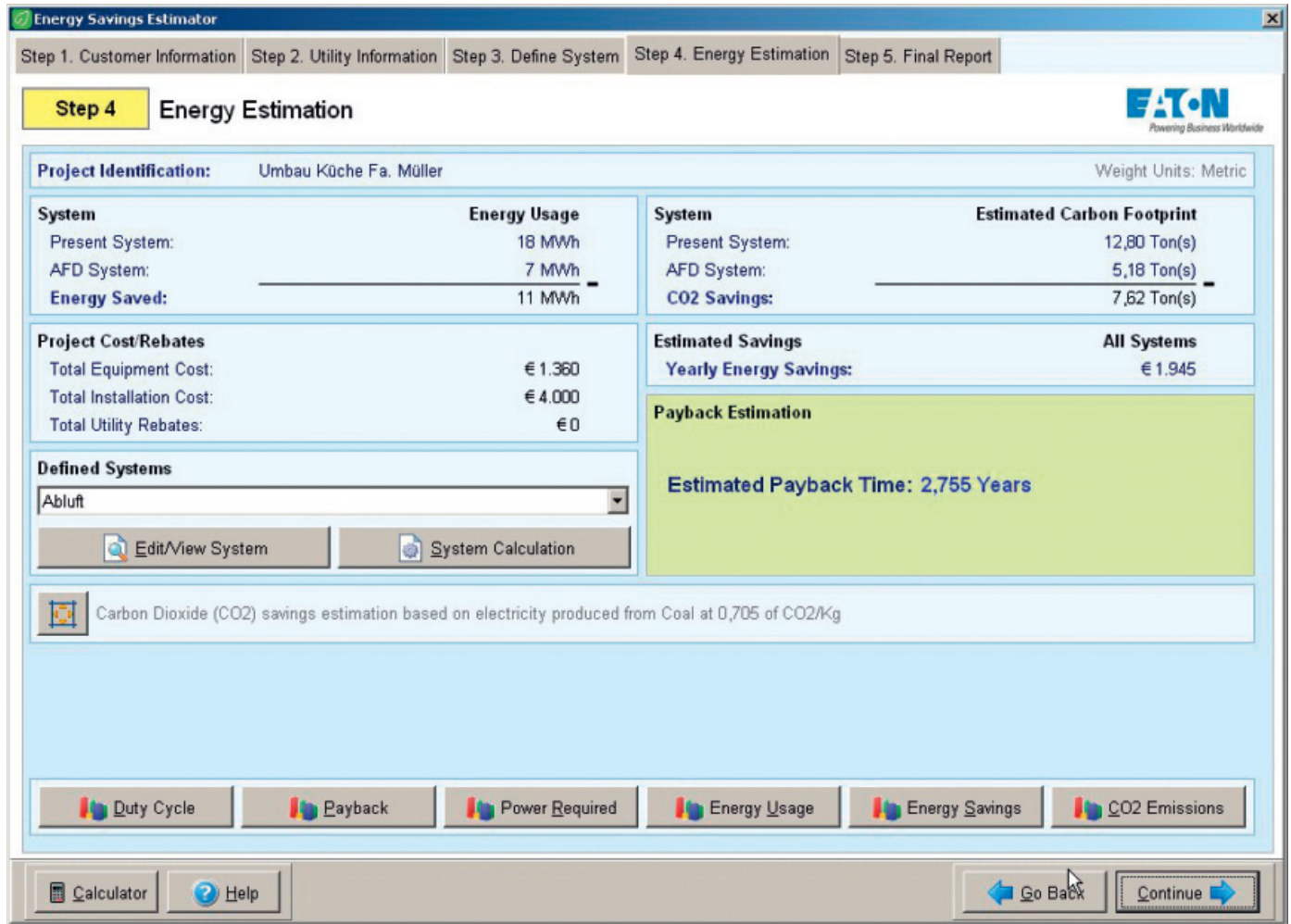

Fig. 5: Energy Saving Estimator software to identify savings potentials in electronic systems, source: Eaton

This reform provides that the area of validity covered by the Motor Directive will be enlarged by step in coming years with the objective of saving even more energy in industrial drive engineering. The legal framework for standard asynchronous motors is as follows:

*Regulation EC 640/2009, Article 3 (excerpt)*

- From 16 June 2011, motors shall not be less efficient than the IE2 efficiency level.
- From 1 January 2015: motors with a rated output of 7.5–375 kW shall not be less efficient than the IE3 efficiency level [...] or meet the IE2 efficiency level [...] and be equipped with a variable speed drive.
- From 1 January 2017: motors with a rated output of 0.75–375 kW shall not be less efficient than the IE3 efficiency level [...] or meet the IE2 efficiency level [...] and be equipped with a variable speed drive.

These new legal frameworks should further increase awareness of energy efficiency issues in industry. Without automation technology, industry will be unable to meet ever-increasing efficiency requirements and climate goals. The market is reflecting the growing importance of automation technology: According to estimates by ZVEI, the global market for measuring technology and process automation will rise from 113 billion (2007) to 213 billion (2020), corresponding to annual growth of around 5%. Key drivers of this development

(at least 25% of the market value of measuring technology and process automation) are green products and systems or have links to energy efficiency and climate protection activities. This figure is expected to rise from 35% to 40% by 2020<sup>12</sup>.

**Save energy, but how?**

There are three main approaches to reducing the energy consumption of a system, each of which offer different savings potentials (in percent in brackets): improving motor efficiency on the basis of the new IE levels (1.4–3%), speed control with a variable drive instead of mechanical throttling (8–10%) or general system optimization (15-20%)<sup>13</sup>.

These figures show that to effectively increase the efficiency of a system it is not enough simply to replace individual components with more efficient products; the system must rather be considered as a whole. Optimum results can only be achieved in the perfect interplay of all components and by selecting the right automation solution for the application in

<sup>12</sup> ZVEI, Economics and statistics, 2009, in ZVEI: Automation, with high-tech for environmental and climate protection – Automation: We do it energy efficiently!, 2010

<sup>13</sup> Prof. Andreas Binder, lecture entitled "Saving Costs and Energy with Efficient Electrical Drives", IHK Nuremberg, January 20, 2009 [in German]

hand. This modified approach, moving away from the component toward the system, is the solution of the future. This is also evident from the fact that a CENELEC (European Committee for Electrotechnical Standardization) working group is already working on a new standard with which the most energy efficient solution for an entire application (motor, switchgear, variable drive) can be determined, including required test methods (CENELEC standard “Energy Efficiency and Ecodesign Requirements for Power Electronics, Switchgear, Controlgear and Power Drive Systems, and their Industrial Applications”).

The integrated approach also means that a comprehensive energy consumption analysis of the entire system and its components is required to identify efficiency gaps and the right tools to close them. As this can be a highly complex process, many manufacturers of automation components provide practical software solutions to help users acquire detailed energy consumption data for their machine or plant (see fig. 5). A program of this type makes it possible to calculate potential savings in advance. Users can thus prevent avoidable risks and even calculate the period in which costs for new equipment, taking energy savings into account, are amortized. Machinery engineers should therefore not balk at high purchase prices for advanced technology but rather consider the value for money over the entire lifetime of the device they wish to acquire (life cycle costs). In the majority of cases, investment in automation components which increase the efficiency of a system is amortized in a remarkably short time.

## Two approaches, one goal

There are two main methods that can be used to take full advantage of the energy savings potential offered by drive control technology: one is to use motor starters to run motors at a set speed after they are started, while the other is to use variable speed starters (VSS) or variable frequency drives to run motors using a variable speed. In both cases, the components only yield the desired results if they are correctly deployed. The following therefore examines the differences, areas of application and usage scenarios of the four most important and well-known start-up methods for starting and controlling three-phase asynchronous motors used in practice.

**A) Motor starters:** Characteristic for the three-phase motor is the high current load on the mains supply with direct-on-line starting. High starting and surge currents results when the full voltage is applied, causing troublesome voltage dips on the mains supply and transient torque effects in mechanical systems. This is especially the case when using IE3 premium efficiency motors, which are characterized by a number of unique properties, including higher starting currents. This makes it particularly important to use high-quality switchgear and protection components with the right trip behavior and with a switching duty designed specifically for the IE3 motor being used. As a complementary element to this strategy, automation solutions are often used in order to eliminate the aforementioned inconvenient side effects and to reduce

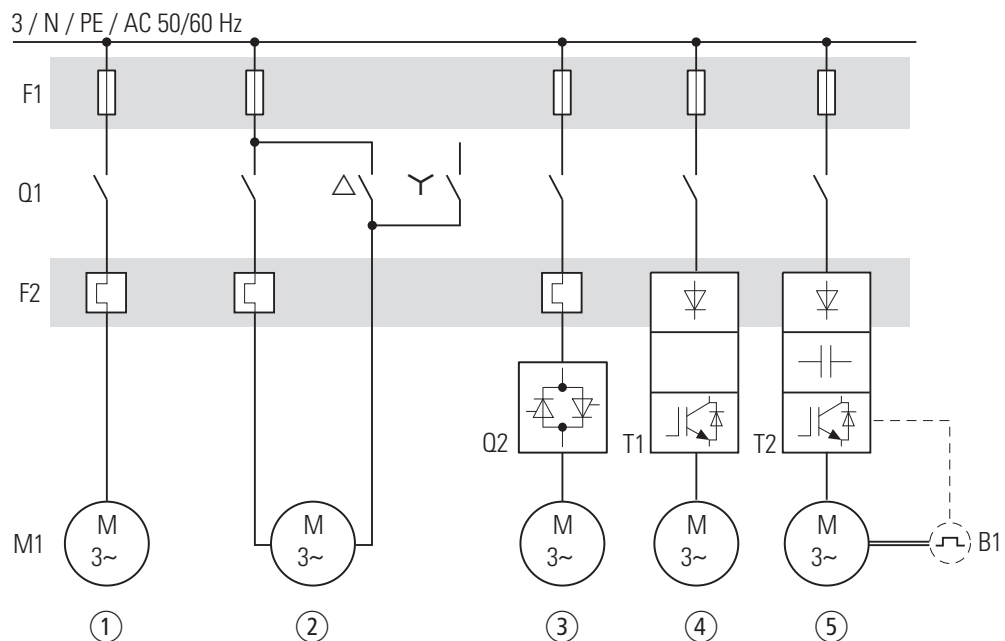

Fig. 6: Motor start variants

F1 = fuse (short-circuit and line protection)

Q1 = switching (contactors)

F2 = motor protection (protection against thermal overload, overload relay)

M1 = three-phase asynchronous motor

① Direct-on-line motor start.

② Star-delta starter, the most well-known and commonly used starting variant.

③ Soft starter (Q2), the continuous and stepless motor start. A modern, electronic alternative to the star-delta starter.

④ Variable speed starter (VSS) (T1), controlled, stepless motor start with rated-load torque. Variable speed starters (VSS) also enable stepless speed control and feature integrated electronic motor protection (I<sup>2</sup>t).

⑤ Variable frequency drive (T2), controlled, stepless motor start with rated-load torque. Frequency drives also enable stepless speed control and feature integrated electronic motor protection (I<sup>2</sup>t). Depending on the characteristic, they also allow exact speed control (option, pulse generator B1) on the otherwise slip-dependent asynchronous motors.

power consumption levels.<sup>14</sup> (Fig. 6: function diagrams of different motor starter types, source: Eaton)

I. *Direct-on-line starter* The direct-on-line motor start is the easiest method for starting up three-phase asynchronous motors. The stator windings are directly connected to the mains supply in a single switching process. The direct-on-line start is ideal for drives in strong networks which permit high starting currents (torque). (Fig. 7: direct-on-line starter, source: Eaton)

II. *Star-delta starter:* With a star-delta motor start, the

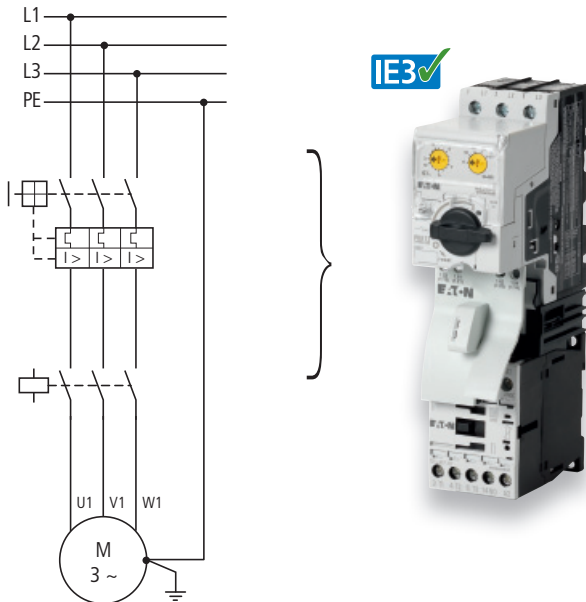

Fig. 7: motor feeder, direct-on-line starter, cw rotation, example of MSC

start-up of the three-phase asynchronous motor is implemented by a changeover of the windings. The jumpers in the motor terminal box are omitted, and all six winding connections are connected to the mains supply using what is called a star-delta switch (manually actuated switch or automatic contactor circuit). In a star connection, the mains voltage ( $U_{LN}$ ) and current on the individual motor windings is reduced by a factor of  $1/\sqrt{3}$  ( $\sim 0,58$ ), reducing the starting torque to around a third of the value for the delta connection. Due to the reduced starting torque, the star-delta configuration is suitable for drives with smaller load torques or load torques (ML) that increase with speed, as is the case with pumps and fans (ventilators/blowers). They are also used where the drive is only subject to a load after it has accelerated up to speed, for example with presses and centrifuges. (Fig. 8: star-delta starter, source: Eaton)

III. *Soft starters:* In many cases, the direct-on-line start and the staged star-delta start of the three-phase asynchronous motor is not the best solution, as high peak currents influence the electrical supply, and torque surges subject the mechanical components of the machine or system to high levels of stress. The soft starter provides a remedy. (Fig. 9, soft starter, source: Eaton). It enables a continuous and surge-free increase in torque and also offer the opportunity for a selective

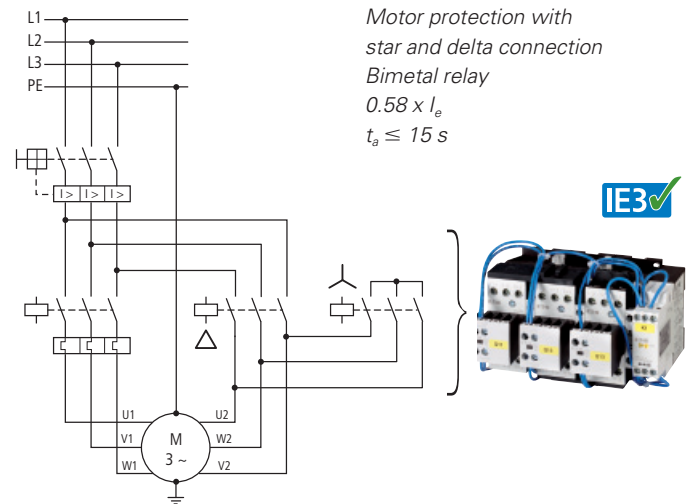

Fig. 8: motor feeder, star-delta starter, cw rotation, example of SDAINL

reduction in starting current. The motor voltage is increased within the adjustable starting time from a selected starting voltage to the rated motor voltage. The soft starter can also control the run down of the drive by reducing the voltage. Soft starters are ideal for drives which require a soft torque characteristic or current reduction. Especially for applications with

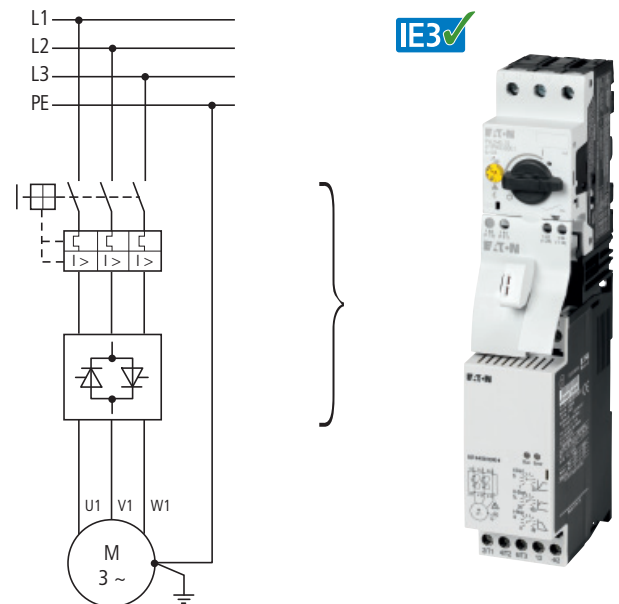

Fig. 9: motor feeder, soft starter DS7, in-line configuration, combined with PKZM0

start-up under load (load cannot be connected after start-up), it should be used in preference to the star-delta configuration. For economic reasons and in consideration of the energy saving potential, it is the optimum solution for high-power drives. Whether users plan to prevent pressure surges in pumping systems, reduce start-up currents with large centrifugal masses or ensure jerk-free start-up of their conveyor systems, soft starters offer a gentle alternative for a jerk-free motor start which protects the supply system (see fig. 10).

14 Jörg Randermann, Starting and Controlling Three-Phase Asynchronous Motors, 2010 [in German]

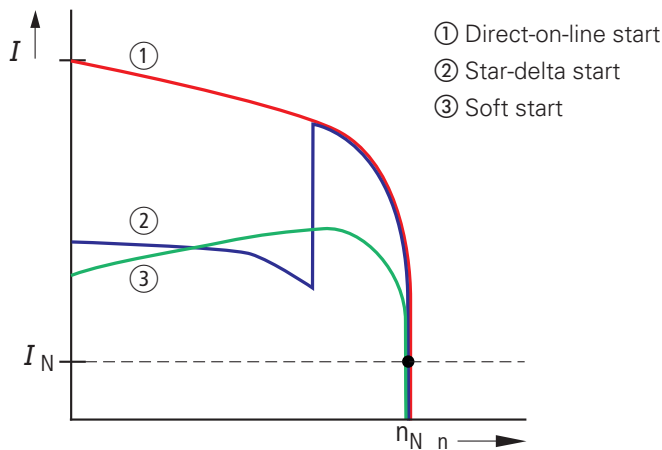

Fig. 10: With adjustable current limiting, soft starters reduce the load on the mains with high inrush current as with direct-on-line starting or current peaks such as in the case of star-delta starts, thus preventing parasitics such as voltage dips. Source: Eaton (homepage)

Which of the three motor starter variants is best suited to the user's application can only be clearly defined following detailed analysis of the system parameters (e.g. project specifications, load profile, physical dimensions), functional requirements (power supply, net load capability, investment costs) and operating conditions (plant productivity, process quality, operating costs).<sup>15</sup> Especially for applications with fixed speeds, motor starters are not just the more affordable but also more efficient solution compared to frequency drives – even disregarding the IE level of the motor (IE2/IE3). To arrive at the best automation solution, it is therefore always important to consider all the system-related factors. It is certainly not the case, as some have claimed, that contactors or motor starters will soon be “banished” from industrial automation. After all, a combination of IE3 motor and contactor is considerably cheaper than an IE2 device with variable frequency drive. Furthermore, the majority of closed-loop controlled drives continue to be fitted with a mains contactor.

Summary: Of the various types of motor starter, soft starters are best suited to reducing peak loads in electric drives with fixed speeds or low switching frequency. Typical example applications are pumps in water reservoirs, agitators in water treatment plants and conveyor systems with constant loads.

### B) Variable speed starters (VSS) and frequency drives:

Increasing the efficiency of a system always involves a combination of improving the energy efficiency of individual components and a product-independent analysis of the overall system.<sup>16</sup>

Variable speed starters (VSS) are a new category of devices used to control asynchronous motors. Functionally, they

can be placed somewhere in between motor starters and today's common variable frequency drives, as they combine the advantages of these two existing categories (the ease of use of a motor starter and the variable speed provided by a variable frequency drive). Accordingly, they are used for simple applications in which variable speeds are required and the range of functionalities provided by a conventional variable frequency drive is not needed or is even too complex.

For many decades, mechanical methods for controlling the flow of liquids and gases were the only way to adjust the rate of delivery to the demands of the respective process. Here, the motor operates at the rated speed required for the maximum rate of delivery almost continuously. The valves and throttles used for the mechanical control represent sources of conversion loss, typically in the form of heat. Today, the speed of a drive can be directly controlled using a variable frequency drive, so that the flow rate of a liquid or gas is adjusted to meet immediate demands.<sup>17</sup> Despite their own heat losses, variable speed starters (VSS) and frequency drives typically improve the average efficiency of an application across the entire operating range.

The adjustable current limitation prevents high current peaks in the electrical mains supply and abrupt loads in the mechanical parts of the machine and systems. In addition to the smooth start-up, the variable speed starter (VSS) and frequency drive also enables stepless speed (frequency) control of the three-phase asynchronous motor. Whereas motors connected directly to the mains supply can only achieve the ideal operating conditions at the steady state operating point (= rating plate specifications), they can be utilized over the entire speed range with frequency control.

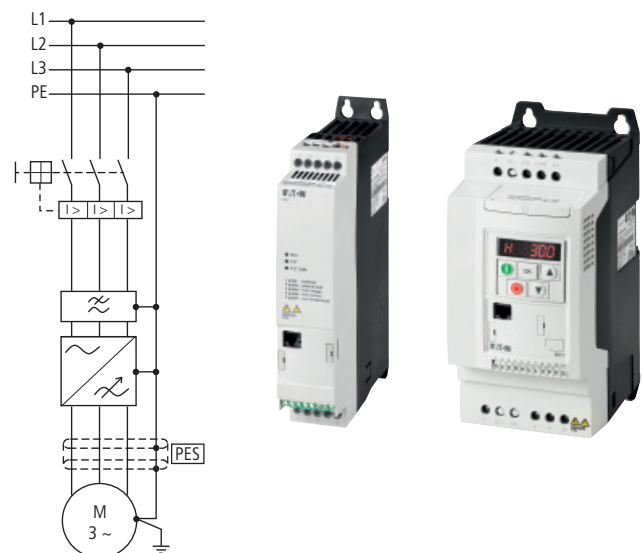

Fig. 11: Motor feeder, variable speed starter (VSS) and frequency drive

<sup>15</sup> Capiel (European Low Voltage Switchgear and Controlgear Manufacturers Association) Journal, What about control gear? Electric motor system efficiency, 2011, [http://capiel.eu/data/Journal\\_CAPIEL\\_MOTEUR-2\\_EN.pdf](http://capiel.eu/data/Journal_CAPIEL_MOTEUR-2_EN.pdf)

<sup>16</sup> Capiel (European Low Voltage Switchgear and Controlgear Manufacturers Association) Journal, What about control gear? Electric motor system efficiency, 2011

<sup>17</sup> Alfred Mörx, lecture entitled “Increasing Energy Efficiency in Drive Engineering in the Light of European Directives and Regulations”, Eaton Vienna, 2013 [in German]

The constant ratio of voltage to frequency ( $U/f$ ) guarantees independent operating points with rated load torque ( $M_N$ ). By matching the rotation speed to the production process and the compensation for external interference, the frequency controlled drive unit guarantees a longer service life and functional security.<sup>18</sup>

The energy savings potential of using frequency drives depends on the following factors: type of driven load, degree of efficiency optimization of the machine by the variable frequency drive and the time in which the overall system operates at partial load. Frequency drives are particularly effective in applications with alternating loads or variable speeds.

The characteristic curves for motor and machine (e.g. pump) are generally given as an interplay of speed ( $n$ ) or torque ( $M$ ) and power ( $P$ ). When it comes to saving energy with frequency drives, machines and systems in which the relationship between speed ( $n$ ) and torque ( $M$ ) is quadratic with a more than linear connection to the power ( $P$ ) are of particular interest. These include applications such as centrifugal pumps and fans. In the world of drive engineering, they are known as continuous-flow machines. The key factor for saving energy here is the cubic relationship between speed and power ( $P$  proportional  $n^3$ ), which, for example, results in a pump which operates at 50% of its maximum speed requiring only 1/8 of the power needed at full speed. This means that a small reduction in speed is enough to produce major savings. A speed reduction of 20% yields a saving of 50% (see fig. 12), because the motor's power consumption is precisely adjusted to meet the actual requirements of the process.<sup>19</sup>

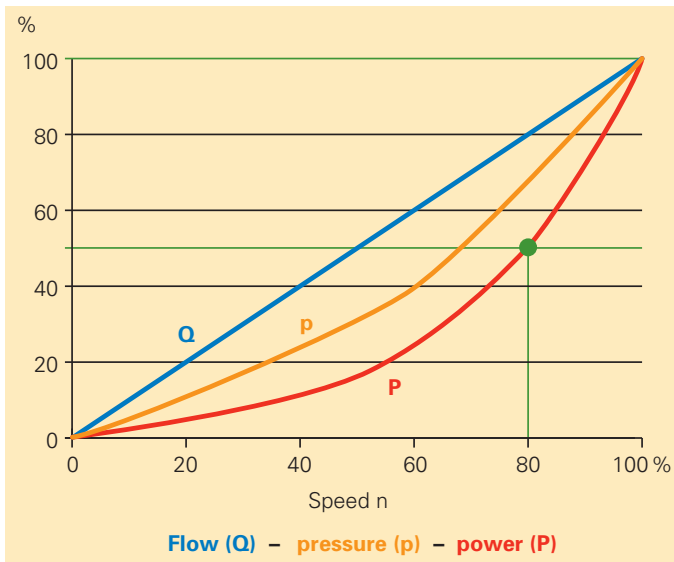

Fig. 12: Relationship (in percent) between flow ( $Q$ ), pressure ( $p$ ), power ( $P$ ) and speed ( $n$ ) in continuous-flow machines (schematic), source: diam-consult

At first sight, the variable speed starter (VSS) and frequency drive appear to be the most expensive way of controlling the speed of asynchronous motors. Higher acquisition costs compared to motor starters and additional installation procedures are the main reasons. But during operation at the very latest, the soft motor start, together with the energy efficiency and process optimization, reveals its economic benefits<sup>20</sup>. This is especially true for pumps and fans, as shown in the following example:

A variable rate of delivery is required in a pump system. Changing the rate of delivery can be done by: (a) using a motor with a constant speed and a throttle valve to adjust the rate of delivery or (b) using a closed-loop controlled drive which adjusts the pump speed to requirements. The typical cycle of a pump system is as follows: 100% rate of delivery in 6% of time, 75% of rate of delivery in 15% of time, 50% rate of delivery in 35% of time, 25% rate of delivery in 44% of time. Controlling the pump by means of a throttle results in high losses and poor efficiency in the overall system. With load-oriented speed control using a variable frequency drive, these losses can be significantly reduced, resulting in high energy savings and a considerable reduction in operating costs (see fig. 13).

In this example, the effective power of the pump is always 100%. In the event of throttling, energy of 2.85 times the effective power must be supplied; with electronic speed control just 1.6 times the power.

Summary: Increasing efficiency with the use of variable speed starters (VSS) and frequency drives is ideal for applications with variable speeds or loads. Load-oriented speed control can be used to achieve considerable savings. Example applications include closed-loop pump and fan systems without throttle, conveyor systems with variable loads, final controlling elements in machine tools.<sup>21</sup>

18 Jörg Randermann, Starting and Control of Three-Phase Asynchronous Motors, 2010

19 Alfred Mörx, lecture entitled "Increasing Energy Efficiency in Drive Engineering in the Light of European Directives and Regulations", Eaton Vienna, 2013 [in German]

20 Jörg Randermann, Starting and Control of Three-Phase Asynchronous Motors, 2010

21 The distinction used here between applications with constant and variable speeds/loads is simplistic and employed only to illustrate the topic of energy efficiency. In more complex systems such as HVAC applications in large buildings, in materials handling engineering or in water supply, combinations of many different control devices are naturally used. These complex combination systems, however, play only a subordinate role in the present context and will therefore not be examined in more detail.

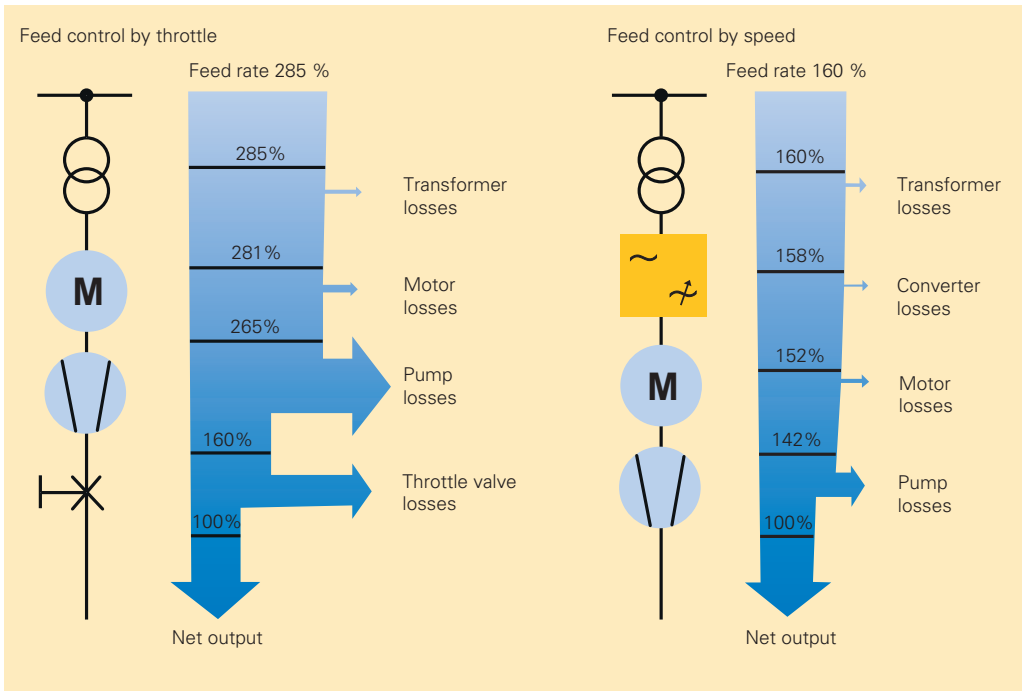

Fig. 13: Comparison of pump system control with mechanical throttling and electrical speed control, source: ZVEI



Fig. 14: The new PowerXL variable family from Eaton

## Conclusion:

At the very latest on the adoption of ErP Directive 2009/125/EC by the European Union, companies in industry are increasingly obliged to further reduce their energy consumption and with it their CO<sub>2</sub> emissions, particularly in electrical drive engineering. Automation solutions such as motor starters and frequency drives can make a substantial contribution here, as long as they are correctly deployed. Users should consider the following three key issues if they want to effectively leverage savings potentials in electronic drive engineering:

1. **The choice of the right drive engineering is a crucial factor of success.** There are essentially two different types of application in electrical drive engineering, each with their own automation solutions.

- Motor starters are the most energy efficient solution for applications with fixed speeds or low switching frequencies.
- Electrical control of the motor speed using a variable frequency drive is the better choice for applications with variable speeds or strongly alternating loads.

2. **From the component to the system:** Energy efficiency should always be seen as an interplay of all components and not pinned down to one single device. The use of more energy efficient components is a good idea in itself, but not enough to maximize the efficiency of the overall system. That is why a comprehensive energy consumption analysis of the entire system is first required to identify the best solution – variable frequency drive or motor starter – for increasing the energy efficiency in the user's application. Only then can the automation solution which best increases the efficiency of the overall system, and the extent of the savings potential, be established with certainty.

3. **From short-term to long-term thinking** It is worth investing in energy efficient technologies such as IE3 motors. Even if modernizing a system initially appears expensive, the use of drive components such as frequency drives and soft starters often quickly pays in terms of savings made. If the total costs over the entire lifetime of a device are considered, the investment is generally amortized after a relatively short period of time. Although it is not yet specified in law, it is worth investing in IE3 technology in combination with inverters or motor starters because it improves compatibility with future modifications to the system.

**Author:** Heribert Joachim, Senior Project Manager Drives at Eaton in Bonn

## Works consulted

- Alfred Mörx, "Increasing Energy Efficiency in Drive Engineering in the Light of European Directives and Regulations", Eaton Vienna, 2013 [in German]
- Almeida, A.T. Ferreira, Fong, J., Fonseca, P., EUP Lot 11 Motors; ISR-University of Coimbra, February 2008
- Arbeitsgemeinschaft Energiebilanzen AGEB: energy balance evaluation tables from 1990 to 2011. [in German]
- Capiel (European Low Voltage Switchgear and Controlgear Manufacturers Association) Journal, What about control gear? Electric motor system efficiency, 2011, [http://capiel.eu/data/Journal\\_CAPIEL\\_MOTEUR-2\\_EN.pdf](http://capiel.eu/data/Journal_CAPIEL_MOTEUR-2_EN.pdf)
- Jörg Randermann, Starting and Controlling Three-Phase Asynchronous Motors, 2010 [in German]
- Directive 2005/32/EC establishing a framework for the setting of ecodesign requirements for energy-using products
- Directive 2009/125/EC establishing a framework for the setting of ecodesign requirements for energy-using products
- Federal Environment Agency, energy consumption by source and sector, March 2013, <http://www.umweltbundesamt-daten-zur-umwelt.de/umweltdaten/public/theme.do?nodent=5978>
- Federal Environment Agency, Press Information No. 53/2009, Energy efficiency in electric motors, 2009 [http://www.umweltbundesamt.de/uba-info-presse/2009/pd09-053\\_energieeffizienz\\_bei\\_elektromotoren.htm](http://www.umweltbundesamt.de/uba-info-presse/2009/pd09-053_energieeffizienz_bei_elektromotoren.htm)
- Prof. Andreas Binder, "Saving Costs and Energy with Efficient Electrical Drives", IHK Nuremberg, January 20, 2009 [in German]
- VDMA / Roland Berger: How the engineering sector contributes to energy efficiency, 2009 [in German]
- Commission Regulation (EC) No. 640/2009 of July 22, 2009, implementing Directive 2005/32/EC of the European Parliament and of the Council with require to ecodesign requirements for electric motors
- ZVEI, based on McKinsey & Company, Inc. "Costs and Potentials of Greenhouse Gas Abatement in Germany", industry report, 2007
- ZVEI, Measuring Technology and Process Automation Division, in: ZVEI: Automation, with high-tech for environmental and climate protection – Automation: We make it energy efficient!, 2010 [in German]
- ZVEI, Economics and statistics, 2009, in ZVEI: Automation, with high-tech for environmental and climate protection – Automation: We make it energy efficient!, 2010 [in German]
- ZVEI, Motors and closed-loop controlled drives – standards and legal requirements for low voltage three-phase motors, 2013 [in German]
- ZVEI: Automation, with high-tech for environmental and climate protection – Automation: We make it energy efficient!, 2010 [in German]

Eaton is dedicated to ensuring that reliable, efficient and safe power is available when it's needed most. With unparalleled knowledge of electrical power management across industries, experts at Eaton deliver customized, integrated solutions to solve our customers' most critical challenges.

Our focus is on delivering the right solution for the application. But, decision makers demand more than just innovative products. They turn to Eaton for an unwavering commitment to personal support that makes customer success a top priority. For more information, **visit [www.eaton.eu/electrical](http://www.eaton.eu/electrical)**.

**To contact an Eaton salesperson or local distributor/agent, please visit [www.eaton.eu/electrical/customersupport](http://www.eaton.eu/electrical/customersupport)**

**Eaton Industries GmbH**

Hein-Moeller-Str. 7-11  
D-53115 Bonn/Germany

© 2014 by Eaton Corporation  
All rights reserved  
Printed in Germany 09/14  
Publication No.: WP040003EN  
ip September 2014  
Article No.: 173442



Eaton is a registered trademark of Eaton Corporation

All other trademarks are property of their respective owners.

SmartWire-DT® is a registered trademark of Eaton Corporation.