

Metal-Enclosed Switchgear— MEF Front-Access Medium Voltage Drawout Vacuum Breakers

Contents

Metal-Enclosed Switchgear—MEF Front-Access Medium Voltage Drawout Vacuum Breakers

General Description	6.0-2
Technical Data	6.0-19
Layouts	6.0-31

Specifications

See Eaton's *Product Specification Guide*, available on CD or on the Web.

CSI Format:	1995	2010
	Section 16347A	Section 26 13 19.11



Note: Viewing windows shown in the photo are illustration only.

MEF Switchgear (5–15 kV)

General Description

Medium Voltage— Drawout Breaker

Eaton's newest Type MEF metal-enclosed front-accessible switchgear with Type VCP-T/VCP-TL drawout vacuum circuit breakers provide centralized control and protection of medium voltage power equipment and circuits in industrial and commercial installations involving:

- Transformer primary switching
- Transformer secondary main
- General purpose feeder circuit
- Bus tie circuit
- Generator Main
- Across-the-line starting of medium voltage motors
- Automatic transfer switching using main-main or main-tie-main configurations
- Harmonic filter bank switching
- Any combination of above applications

Type MEF metal-enclosed switchgear is designed for application at voltages up to 15 kV. It is a modularized design that can be assembled in various combinations to satisfy user application requirements. The switchgear can be supplied with one-high or two-high breaker arrangements. Type MEF switchgear is a front-accessible design, suitable for installation against the wall.

For metal-clad, rear-access switchgear design, refer to Tab 5, type VCP-W switchgear.

Standards

MEF metal-enclosed switchgear is designed to meet requirements of C37.20.3, IEEE® standard for metal-enclosed switchgear. Drawout circuit breakers and auxiliary drawers are designed to meet requirements of C37.20.2, IEEE standard for metal-clad switchgear.

MEF also meets Canadian Standard, CSA® C22.2 No. 31-04.

Type VCP-T/VCP-TL vacuum circuit breakers used in MEF switchgear meet or exceed ANSI and IEEE standards applicable to AC high voltage circuit breakers rated on symmetrical current basis; C37.04, C37.06, C37.09.

Third-Party Certifications

- UL®
- CSA



MEF Switchgear—Indoor Unit



VCP-T/VCP-TL Circuit Breaker with Integral Protective Relay



VCP-T/VCP-TL Circuit Breaker

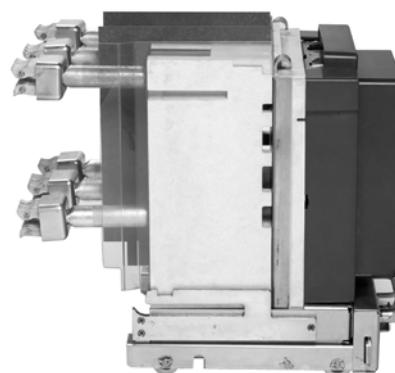

VCP-T/VCP-TL Circuit Breaker—Side View

Seismic Qualification



Refer to **Tab 1** for information on seismic qualification for this and other Eaton products.

Ratings

- Rated maximum voltage: 4.76 kV, 15 kV
- Rated main bus continuous current: 1200, 2000 A
- Circuit breaker ratings: continuous current 600, 1200, 2000 A
- Rated short-circuit current: 16, 20, 25, 32 and 40 kA
- Refer to **Table 6.0-3** and **Table 6.0-4** for more details

General Description—VCP-T/VCP-TL Vacuum Circuit Breaker

Advantages

- Reduced footprint
- Front-access design
- Maintenance-free bus joints
- Full benefits of switching and interrupting capabilities of vacuum breakers
- Integral relaying and metering by use of breaker mounted protection that allows full short-circuit and overload coordination with upstream devices
- External control power is not required when using integral protection
- Optional external relays and meters
- MEF fills the application gap between metal-enclosed fusible load interrupter and metal-clad breaker switchgear designs
- Breakers shipped installed in the switchgear; no mismatch or misplaced circuit breakers at site and reduced installation cost

Features—VCP-T/VCP-TL Vacuum Circuit Breaker

- Vacuum circuit breakers provide high duty cycle, fast interruption, reduced maintenance, and are environmentally friendly
- Very compact and lightweight circuit breaker rated to 15 kV; weighs only 250–440 lb (114–200 kg)
- Fully horizontal drawout feature with connect, test and disconnect positions provides ease of operation and interchangeability. Levering-in (racking) system is an integral part of the breaker
- All circuit breaker functions, indicators and controls are grouped on an easily accessible panel on front of the circuit breaker
- Levering interlock prevents the breaker from being racked out when in connected position and closed
- Trip-free interlock prevents breaker from closing, manually or electrically, while it is being levered or when in an intermediate position

- Secondary control connector interlock prevents breaker being moved into the connected position if the breaker control wiring connector is not correctly engaged with its compartment control wiring connector. Interlocking also prevents disconnection of circuit breaker control wiring connector, manually or automatically, while the circuit breaker is in the connected position and in any position between the connected and the test/disconnected
- Breaker frame remains grounded throughout its travel and in the connected position
- Choice of manually or electrically operated circuit breakers
- Integral spring charging handle
- Choice of breaker mounted protection for automatic short-circuit and overload protection without a need for external control power
- Can also be used with external relays when equipped with optional shunt trip and external control power
- Easy-to-see contact erosion indicator is provided on the moving stem of the breaker. Only visual inspection is required to verify that the contacts have not worn out
- Easy-to-see contact wipe indicator is provided for verification by simple visual inspection that the loading springs are applying proper pressure to the contacts when the circuit breaker is closed
- One auxiliary switch (5a, 5b) included as standard on all breakers for breaker contact status
- Quality Assurance Certificate is included with each circuit breaker



VCP-T/VCP-TL Circuit Breaker Fully Withdrawn on Extension Pan

General Description—VCP-T/VCP-TL Vacuum Circuit Breaker

Choice of Breakers

VCP-T/VCP-TC Breakers



VCP-T/VCP-TC Breaker

- ANSI rated—drawout
- Equipped with stored energy spring operating mechanism
- 5/15 kV, 600/1200/2000 A
- 25 kA and 40 kA rms symmetrical
- K = 1
- Rated interrupting time = 3 cycle
- Operating mechanism = 10,000 operations
- Vacuum interrupters = 30,000 operations

VCP-TL/VCP-TLC Breakers



VCP-TL/VCP-TLC Breaker

- ANSI rated—drawout
- Equipped with linear magnetic actuator operating mechanism
- 5/15 kV, 600/1200 A
- 25 kA rms symmetrical
- K = 1
- Rated interrupting time = 3 cycle
- Operating mechanism = 100,000 operations
- Vacuum interrupters = 30,000 operations

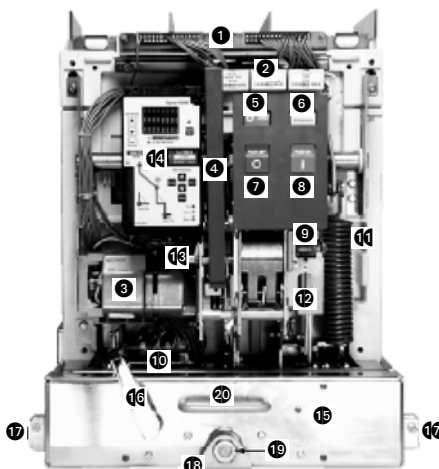

VCP-T Breaker

- | | |
|--------------------------------------|---|
| 1 Secondary Wiring | 11 Opening Spring |
| 2 Through-the-Window Accessories | 12 OFF Key Lock Location |
| 3 Electric Charging Motor | 13 Motor Cutoff Switch |
| 4 Manual Charging Handle | 14 Integral Protective Relay (Optional) |
| 5 Contact Status (Open-Close) | 15 Cradle with Levering Mechanism |
| 6 Spring Status (Charged-Discharged) | 16 Shock Bolt Handle |
| 7 Manual "OFF" Pushbutton | 17 Shock Bolt |
| 8 Manual "ON" Pushbutton | 18 Packing Screw Lock Plate |
| 9 Operations Counter | 19 Levering Drive Nut |
| 10 5A/5B Auxiliary Switch | 20 Push/Pull Handle |

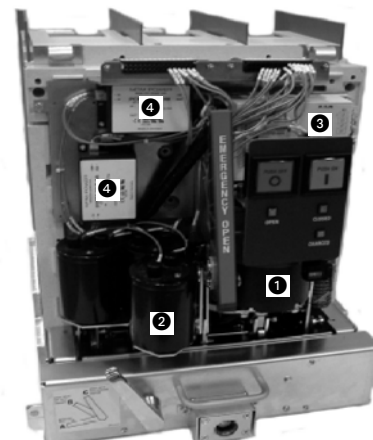

VCP-TL Breaker

- | |
|---------------------|
| 1 Magnetic Actuator |
| 2 Capacitor |
| 3 Controller |
| 4 Power Supply |

Notes:

1. Type VCP-TC and VCP-TLC are optional designs with capacitor switching capabilities. See **Table 6.0-5** on **Page 6.0-19**.
2. VCP-TL/VCP-TLC breakers are designed such that in event of control power loss, internal capacitors provide sufficient energy to perform an electrical open operation up to 48 hours after the loss of control power.

Features—MEF Switchgear Assembly

Type MEF is metal-enclosed front-accessible switchgear with many metal-clad features.

- Drawout circuit breaker and auxiliary (VT, CPT) compartments with automatic shutters to prevent accidental contact with high voltage circuits when breaker/auxiliary is removed
- No high voltage connections or circuits are exposed by opening of circuit breaker, VT or CPT compartment door
- All drawout elements are provided with mechanical interlocks for proper operating sequence under normal operating conditions as described in IEEE C37.20.2
- All low voltage control wiring, devices and control compartments are isolated from high voltage circuits

MEF Switchgear is Compact

- Breaker and auxiliary cells are 26.00-inch wide, 61.50-inch deep, 92.00-inch tall (660.6 mm wide, 1562.1 mm deep, 2336.8 mm tall)
- Cable pull sections are 19.00 inches wide, 61.50 inches deep, 92.00 inches tall (482.6 mm wide, 1562.1 mm deep, 2336.8 mm tall)
- Reduced front aisle space for breaker withdrawal saves overall floor space
- Shipping groups can be moved in place by forklift, or overhead lifting means

MEF Switchgear is Modular

Available configurations include:

- Breaker over auxiliary
- Breaker over breaker
- Auxiliary over auxiliary
- Pull sections with various cable entry combinations

MEF Switchgear is Front Accessible

- Allows primary cable connections from the front of the switchgear
- All drawout elements (breaker, VT, CPT) are front accessible after opening their compartment door
- All field connections required at shipping splits are accessible and made from the front
- No rear access space is required. The switchgear can be installed against the wall
- All non-accessible primary bus joints and connections are maintenance-free—do not require inspection or re-torque



MEF Switchgear—Indoor Unit

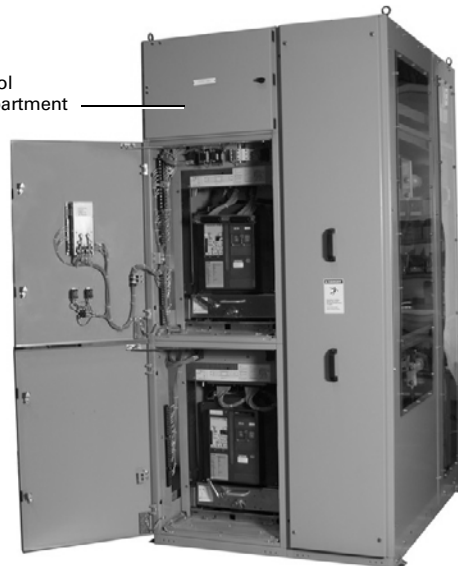

MEF Switchgear—Breaker Over Breaker and Adjacent Pull Section



MEF Switchgear—Single Breaker with Cables Out the Bottom

General Description—MEF Switchgear

Circuit Breaker Compartment

- Each circuit breaker compartment is provided with steel shutters (breaker driven) that automatically rotate into position to cover stationary cell studs to prevent contact with high voltage circuit when the breaker is moved from connected to disconnected position. Provisions for padlocking the shutters open or closed is included as standard
- Rejection interlock pins prevent insertion of the circuit breaker if the circuit breaker and structure ratings are not compatible
- A silver-plated copper ground bus keeps the breaker grounded throughout its travel and in its connected position



*Circuit Breaker Compartment—
Breaker in Connected Position*



*Circuit Breaker in Connected
Position Indicator*

6

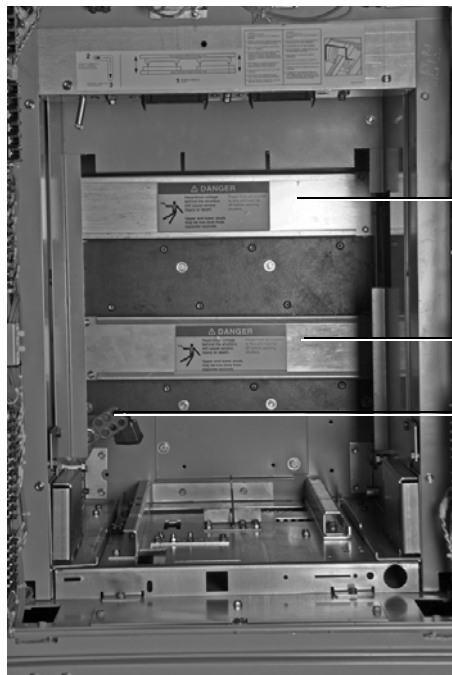

VCP-T Circuit Breaker Compartment

Steel
Shutters

Provision
for Padlock
Shutters

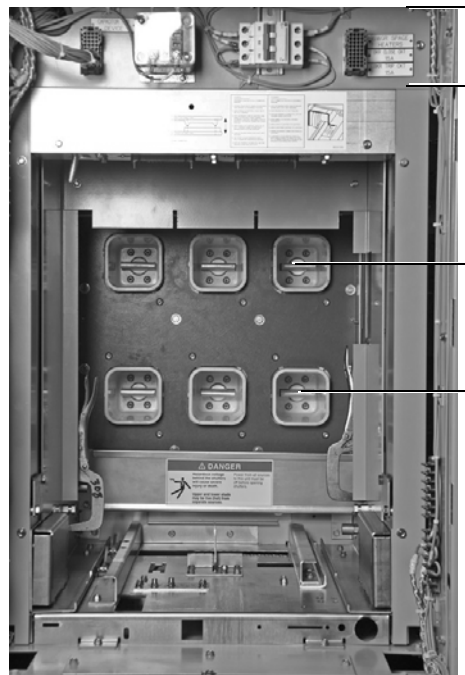

*VCP-T Circuit Breaker Compartment
(Shutters Shown Open for Illustration)*

Panel Space
for LV
Control
Devices

Cell
Stabs

Auxiliary Compartments

MEF switchgear permits use of up to four auxiliary drawers in one vertical unit. Those drawers can be used for installation of voltage or control power transformers.

- Each drawer can be fully withdrawn on extension rails, thus allowing easy access to VT, CPT and their primary fuses
- Safety shutter protects against accidental contact with primary stabs when the drawer is withdrawn
- A VT drawer can accommodate two VTs, each connected line-to-line (open delta), or three VTs, each connected line-to-ground
- A CPT drawer can accommodate a maximum of single-phase, 5 kVA CPT
- Mechanical interlock is included on CPT drawer that requires CPT secondary breaker to be opened prior to withdrawing the drawer to ensure that the primary circuit can only be disconnected under no-load
- Primary fuses are automatically grounded as the drawer is withdrawn from connected to disconnected position

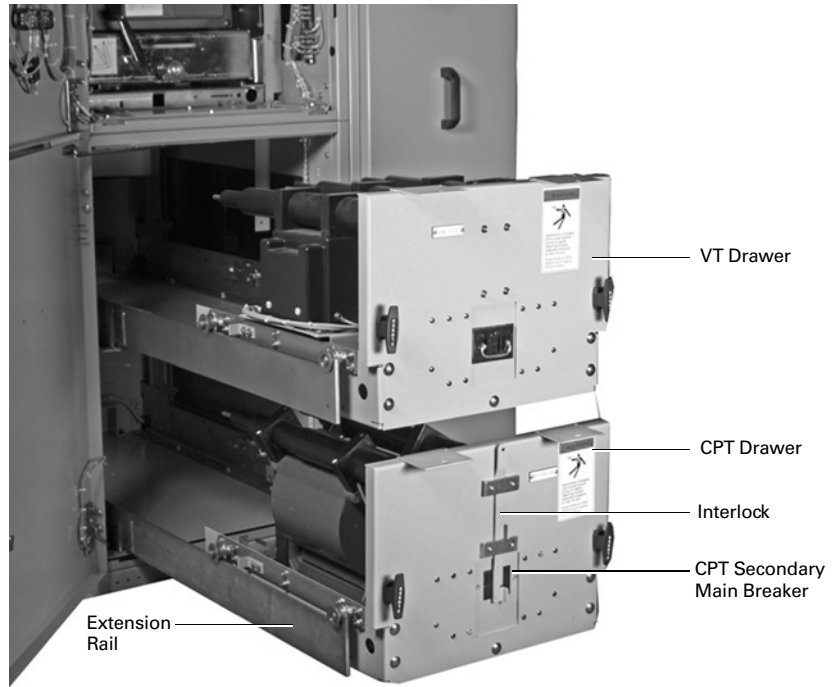

Drawout VT and CPT

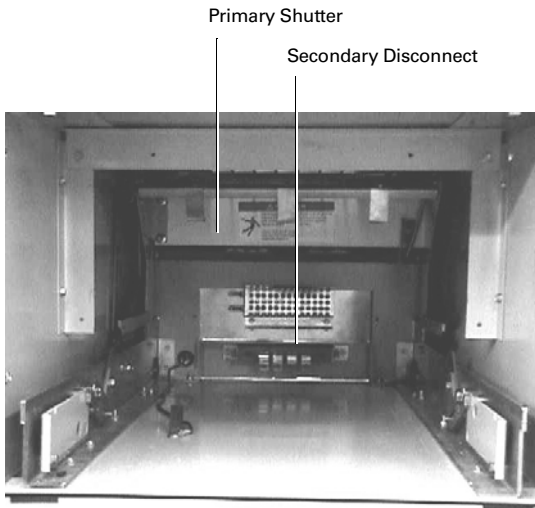

Auxiliary Drawer Compartment

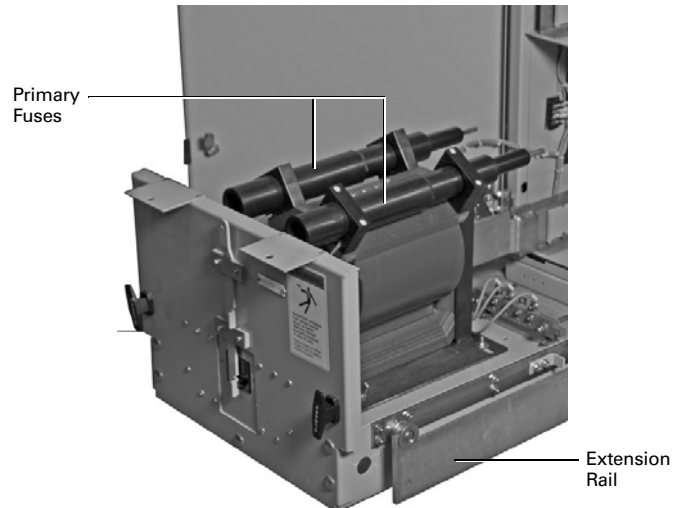

CPT Withdrawn on Extension Rails

Cable Pull Sections



MEF Cable Pull Section Adjacent to 2-High Breaker Cell

Cable pull sections are included as required to allow top or bottom primary cable terminations from the front of the switchgear. Current sensors for use with breaker mounted integral protective relay, or current transformers for use with door mounted external relays are mounted in the primary circuits in the pull sections. Pull sections are also used as needed for bus transition and bus connections to other equipment. Pull section is metal-enclosed.

CT/Sensor
Secondary Wires

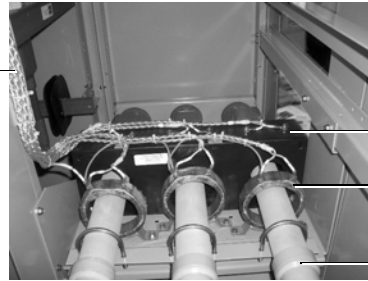

Three-Phase CT
Single-Phase Current Sensors
CT/Sensor Primary Bushings

Pull Section Close-Up View CT/Sensor Mounting

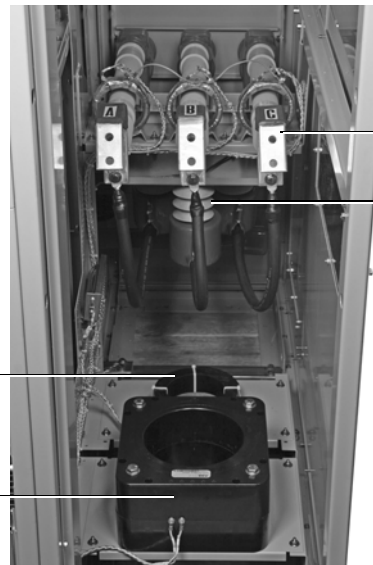

Customer's Cable Terminal Pads
Surge Arresters

Zero Sequence Sensor

Zero Sequence CT

Pull Section Close-Up View Cable Termination and Zero Sequence CT/Sensor

Bus Compartments

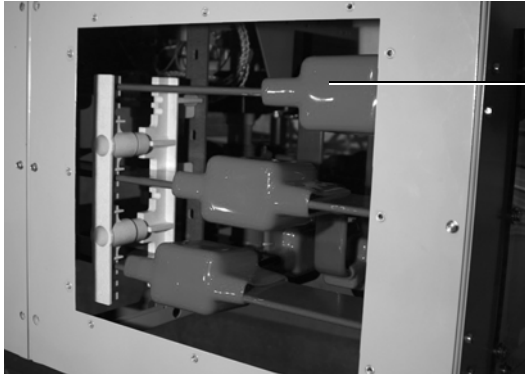

Main Bus Joint with PVC Boot

Top View—Main Bus Access

Type MEF switchgear is completely front accessible, designed to be installed against a wall. Access necessary for customer’s primary cable terminations, joining of bus joints (main bus and ground bus) at shipping splits, and terminations of customer’s control wires are provided from the front of the switchgear. Main bus is accessible from the top front of the switchgear. All bus bars are insulated throughout by epoxy coating using Eaton’s fluidized bed process, and covered with PVC boots at joints. All joints are silver-plated. All bus joints that are not accessible are bolted with special hardware to eliminate need for future inspection or re-torque. Minimum 24.00-inch (609.6 mm) clearance to ceiling is recommended for main bus access.

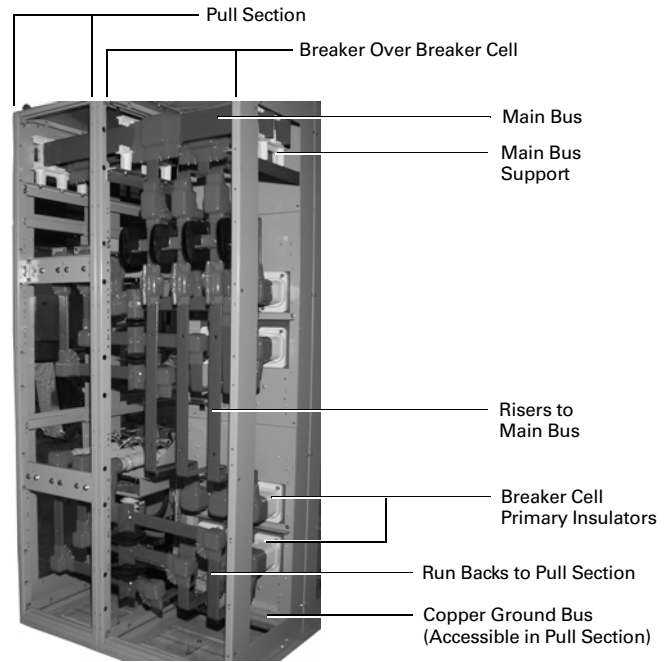

Rear View (Shown with Rear Covers Removed for Illustration Purposes)

General Description

Protection and Metering

Type MEF switchgear with VCP-T/VCP-TL circuit breakers can be supplied with integral breaker mounted protective relays for overload and short-circuit protection and metering. The integral relays are self-powered from specially designed and tested current sensors. MEF switchgear can be supplied with external relays and meters connected to current transformers and powered from an external auxiliary power.

Integral Protection and Metering

- Type VCP-T/VCP-TL circuit breakers can be equipped with Eaton's Type Digitrip 520MCV or Digitrip 1150V protection relays
- The Digitrip 520MCV is used for basic overcurrent protection
- The Digitrip 520MCV relay includes an Arcflash Reduction Maintenance System™ (ARMS) feature that may be activated at the breaker or from remote. When activated, the ARMS feature lowers the available arc flash energy at the connected downstream device by faster clearing of the downstream fault
- The Digitrip 1150V is used for advanced current and voltage protections, and metering and communication functions. ARMS feature is included on 1150V relay as standard
- The 520MCV and 1150V relays are designed and tested to work with Eaton's Type V current sensors only

The power required to operate the protective relay's basic overcurrent protection functions is provided by secondary output from the current sensors once the three-phase primary current through the circuit breaker exceeds approximately 10 to 12% of the current sensor rating or single-phase primary current exceeds approximately 30% of the current sensor rating.

The relay continuously analyzes secondary current signals from the current sensors and when preset current levels and time delay settings are exceeded, sends a trip signal to the trip actuator of the circuit breaker. The trip actuator causes tripping of the circuit breaker by providing the required mechanical force for tripping. The trip actuator is automatically reset each time the circuit breaker opens.

The current sensors, protective relay and circuit breaker are fully tested as a system for time-overcurrent response over the entire current range up to the interrupting rating of the circuit breaker.

An optional Overcurrent Trip Switch (OTS) with one latching type Form C contact can be provided to indicate tripping of the circuit breaker by the action of an integral protective relay.

Rating Plug

A rating plug matched to phase current sensor rating is installed on all integral protective relays. The rating plug and phase current sensors define maximum continuous current rating (I_{rn}) of the circuit breaker. The rating plug and phase current sensors also determine the maximum instantaneous setting.

If the rating plug is removed from the protective relay, the circuit breaker will trip if it is carrying current. See **Page 6.0-25** for available phase current sensors and rating plugs.

General Description

**Digitrip 520MCV
Integral Protective Relay**

The Digitrip 520MCV integral protective relay is used when basic three-phase (50/51) and ground (50/51N or 50/51G) overcurrent protection is required. The relay is a microprocessor-based device that operates from secondary output of current sensors and provides true rms sensing of each phase and ground, and is suitable for application at either 50 or 60 Hz systems. The sensing current for ground protection can be derived from residual connections of the phase sensors or from an optional Type-V zero sequence current sensor. The relay does not require external control power for its protection functions and can be applied with Manually or Electrically Operated circuit breakers.

The 520MCV relay provides a number of time-overcurrent response curves and settings for phase, as well as ground protection and coordination with upstream or downstream devices. It can also be zone interlocked with other upstream or downstream relays for faster selective tripping.

The 520MCV includes an Arcflash Reduction Maintenance System (ARMS) feature when enabled, it reduces arc flash incident energy during equipment maintenance.

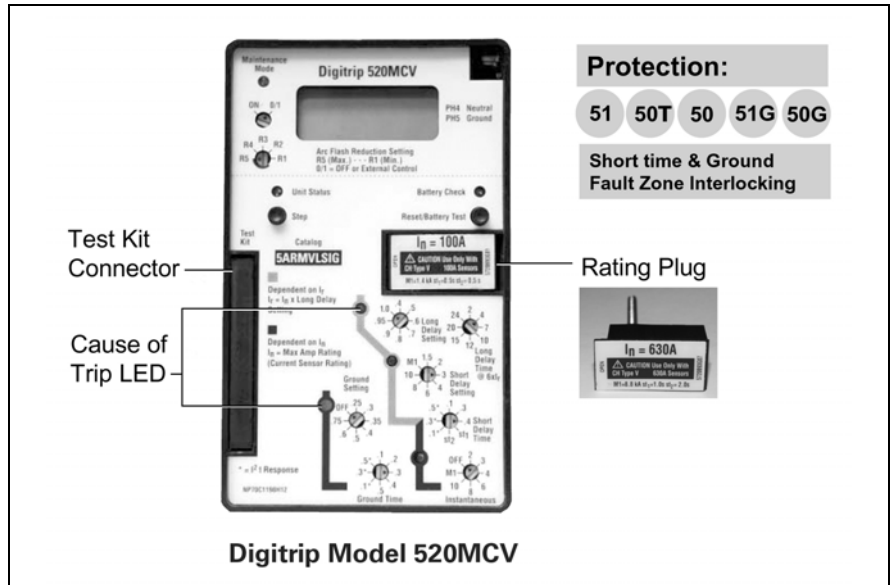

Figure 6.0-1. VCP-T Vacuum Circuit Breaker Digitrip Model 520MCV

Table 6.0-1. Digitrip 520MCV Protection and Coordination

IEEE Device Number	Protection Function	Available Settings (50 or 60 Hz)
Phase Long Delay		
51	Pickup setting (I _r) ^① Time delay, I ² t Thermal memory	(0.4, 0.5, 0.6, 0.7, 0.8, 0.9, 0.95, 1.0) times I _n (2, 4, 7, 10, 12, 15, 20, 24 seconds) at 6 times I _r Enable/disable
Phase Short Delay		
50T	Pickup setting ^② Time delay, FLAT ^③ Time delay, I ² t ^④	(1.5, 2, 3, 4, 6, 8, 10) times I _r , M1 0.1, 0.3, 0.4, st1, st2 seconds (0.1, 0.3, 0.5 seconds) at 8 times I _r
Phase Instantaneous		
50	Pickup setting ^②	(2, 3, 4, 6, 8, 10) times I _n , M1, OFF
Ground Fault		
51/50G	Pickup setting ^⑤ Time delay, FLAT Time delay, I ² t ^⑥	(0.25, 0.3, 0.35, 0.4, 0.5, 0.6, 0.75) times I _n , OFF 0.1, 0.2, 0.3, 0.4, 0.5 second (0.1, 0.3, 0.5) at 0.625 times I _n
Zone Selective Interlocking		
—	Phase short delay and ground fault	Enable/disable
ARMS Mode Settings		
Settings	Pickup	
R5	2.5 x rating plug amperes	
R4	4.0 x rating plug amperes	
R3	6.0 x rating plug amperes	
R2	8.0 x rating plug amperes	
R1	10.0 x rating plug amperes	

① I_n = Current Sensor/Rating Plug rating in amperes.
 ② M1 = Maximum Setting based on I_n
 = (12 x I_n) for I_n = 1600 and 2000 A;
 = (14 x I_n) for all other values of I_n
 ③ st1 and st2 settings are based on I_n

I _n	st1	st2
100 A	0.5 sec	0.5 sec
200–400 A	0.5 sec	1.0 sec
600–2000 A	1.0 sec	2.0 sec

 ④ I²t response is applicable to currents less than (8 x I_r).
 For currents greater than (8 x I_r), the I²t response reverts to FLAT response.
 ⑤ When using phase residual connection scheme, I_n is current sensor/rating plug rating in ampere.
 When using zero sequence connection scheme, I_n is zero sequence current sensor rating in ampere.
 ⑥ I²t response is applicable to currents less than (0.625 x I_n).
 For currents greater than (0.625 x I_n), the I²t response reverts to FLAT response.

General Description

Digitrip 1150V Integral Protective Relay

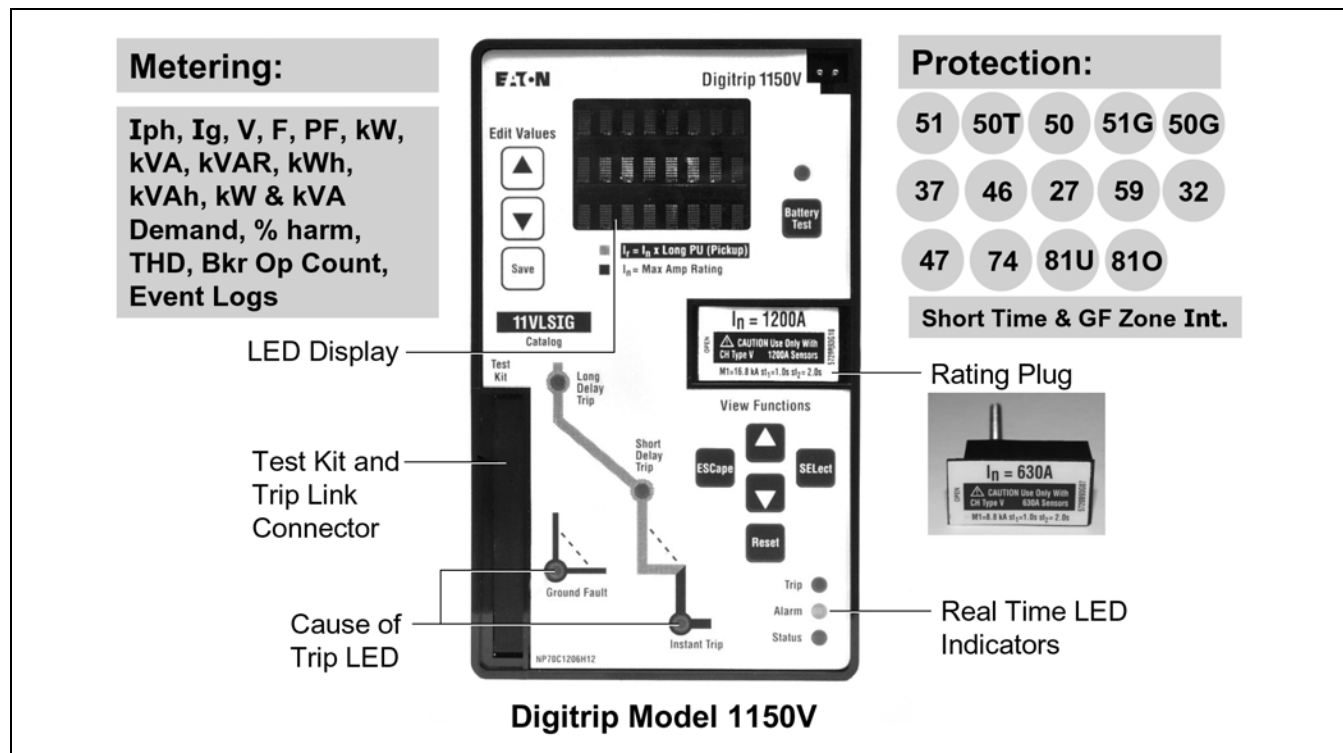

Figure 6.0-2. VCP-T Vacuum Circuit Breaker Digitrip Model 1150V

The Digitrip 1150V integral protective relay is used for advanced current and voltage protection, and metering and communication.

The Arcflash Reduction Maintenance System (ARMS) feature is included on 1150V units as standard. When enabled, it reduces arc flash incident energy during equipment maintenance.

The relay is a microprocessor-based device that operates from secondary output of current sensors and external voltage transformers, provides true rms sensing of each phase and ground, and is suitable for application at either 50 or 60 Hz systems. The sensing current for ground protection can be derived from residual connections of the phase sensors or from an optional Type-V zero sequence current sensor.

The basic overcurrent protection functions of this relay are self-powered from the current flowing in the secondary of the current sensors. It does not require external auxiliary power for its voltage and frequency related protection and alarm functions, and metering displays. The relay can be applied with manually or electrically operated circuit breakers.

The 1150V relay provides following ANSI/IEEE protection functions:

51/50, 51/50N or 51/50G, 37, 46, 27, 59, 81U, 81O, 47 and 32.

The 1150V relay provides a number of time-overcurrent response curves and settings for phase, as well as ground protection and coordination with upstream or downstream devices. It can also be zone interlocked with other upstream or downstream relays for faster and selective tripping.

In addition to display of metering values as noted in **Figure 6.0-2** above, the relay provides data through its front panel display to help plan inspection and maintenance schedules of the circuit breaker and the circuit it is protecting. Those data include:

- Total number of Close Operations by circuit breaker since last reset
- The last time the circuit breaker was operated (Opened or Closed or Tripped) with time and date
- Total number of instantaneous and short delay trip operations by the circuit breaker since last reset
- Total number of overloads (long delay trips) and ground fault trips since last reset

The 1150V relay is also suitable for communication using the INCOM communications system. All monitored values, trip/alarm events, and captured waveforms can be displayed on a remote computer. Breakers can also be opened/closed remotely with password protection. Peripheral translator/gateway devices are available to convert INCOM to other protocols, such as Modbus® RTU, Modbus TCP, etc.

The relay has a built-in 24-character alphanumeric LED display to allow programming and viewing of settings, menus, trip and alarm logs, and real time metering data. Because the relay is installed on the circuit breaker, the breaker compartment door must be opened for viewing or programming of the relay functions. An optional Breaker Interface Module can be used for monitoring, viewing and programming of multiple relays from an alternate location, eliminating the need to open circuit breaker compartment door. Also available is wireless transceiver for short-range infrared wireless communication between a hand-held Palm™ personal data assistant (PDA) and the Digitrip 1150V relays with compartment doors closed.

General Description

Table 6.0-2. Digitrip 1150V Protection and Coordination

IEEE Device Number	Protection Function	Available Settings (50 or 60 Hz)
Phase Long Delay		
51	Pickup setting (I_r) Time delay, I^2t Time delay, I^4t IEEE moderately inverse IEEE very inverse IEEE extremely inverse Thermal memory	(0.4–1.0, in steps of 0.05) times I_n ^① (2–24 seconds, in steps of 0.5) at 6 times I_r (1–5 seconds, in steps of 0.5) at 6 times I_r Time dials of 0.1–5.0, in steps of 0.1 Time dials of 0.2–5.0, in steps of 0.1 Time dials of 0.2–5.0, in steps of 0.1 Enable/disable ^②
Phase Short Delay		
50T	Pickup setting Time delay, FLAT Time delay, I^2t	(1.5–12 or 1.5–14, in steps of 0.5) times I_r ^③ 0.1–2 seconds, in steps of 0.05 ^④ (0.1–2 seconds, in steps of 0.05) at 8 times I_r ^{④⑤⑥}
Phase Instantaneous		
50	Pickup setting	(2–12 or 2–14) times I_n , OFF ^③
Ground Fault		
51/50G	Pickup setting Time delay, FLAT Time delay, I^2t Thermal memory	(0.24–1.0, in steps of 0.01) times I_n , OFF ^⑦ 0.1–0.5 seconds, in steps of 0.05. (0.1–0.5 seconds, in steps of 0.05) at 0.625 times I_n ^⑧ Yes
Zone Selective Interlocking		
—	Phase short delay and ground fault	Enable/disable
Phase Loss (Current Based)		
37	Pickup Time delay	75% current unbalance, OFF 1–30 seconds
Current Unbalance		
46	Pickup Time delay	5–25% current unbalance, OFF 0–240 seconds
Undervoltage		
27	Pickup Time delay	45–110% of phase-to-phase voltage, OFF 1–250 seconds
Overvoltage		
59	Pickup Time delay	80–135% of phase-to-phase voltage, OFF 1–250 seconds
Underfrequency		
81U	Pickup—50 Hz system Pickup—60 Hz system Time delay	48–52 Hz, in steps of 0.1, OFF 58–62 Hz, in steps of 0.1, OFF 0.2–5 seconds, in steps of 0.02
Overfrequency		
81O	Pickup—50 Hz system Pickup—60 Hz system Time delay	48–52 Hz, in steps of 0.1, OFF 58–62 Hz, in steps of 0.1, OFF 0.2–5 seconds, in steps of 0.02
Voltage Unbalance		
47	Pickup Time delay	5–50% voltage unbalance, OFF 1–250 seconds
Reverse Power		
32	Pickup Time delay	1–65000 kW 1–250 seconds

① I_n = Current Sensor/Rating Plug rating in amperes.
 ② Thermal memory feature is available when using I^2t or I^4t curves only.
 ③ Maximum Setting is based on I_n :
 = (12 x I_n) for I_n = 1600 and 2000 A;
 = (14 x I_n) for all other values of I_n
 ④ Upper limit of this setting is 0.5 for 100 A sensor/rating plug, 1.0 for 200 to 400 A sensor/rating plug, and 2.0 for sensors/rating plugs rated above 600 A.
 ⑤ I^2t response is applicable to currents less than (8 x I_r).
 For currents greater than (8 x I_r), the I^2t response reverts to FLAT response.
 ⑥ I^2t response curve for phase short delay is only available when phase long delay response selected is I^2t .
 ⑦ When using phase residual connection scheme, I_n is current sensor/rating plug rating in amperes. When using zero sequence connection scheme, I_n is zero sequence current sensor rating in amperes.
 ⑧ I^2t response is applicable to currents less than (0.625 x I_n). For currents greater than (0.625 x I_n), the I^2t response reverts to FLAT response.

ARMS Mode Available Trip Current Settings

The 1150V unit provides the following pick-up settings:

- 2.5 x rating plug amperes
- 4.0 x rating plug amperes
- 6.0 x rating plug amperes
- 8.0 x rating plug amperes
- 10.0 x rating plug amperes

Metering, Power Quality and Other Features

- Individual phase and ground currents in rms amperes, real time
- Individual phase and ground currents in rms amperes, 5-minute average
- Individual phase and ground currents, maximum and minimum since last reset
- Line-to-line voltages
- Forward/reverse kW, kW demand and maximum kW demand
- kVA, kVA demand and maximum kVA demand
- Watt and VA demand, maximum W and VA demand
- Forward/reverse kWh
- kVAh
- kVAh and kWh pulse initiate
- Total harmonic distortion for each phase current
- Individual harmonic currents up through 27th harmonic for each phase
- Power factor, minimum and maximum
- Frequency
- Circuit breaker operations count
- Programmable alarms
- Programmable output contacts (breaker close, alarm, trip)

Metering Accuracy

- ±1% of full-scale (I_n) for currents in the range of 5–100% of (I_n)
- ±3% of full-scale for voltages (full scale is equal to phase-to-phase voltage)
- ±4% of full-scale for power and energy readings

General Description

**External Protection
and Metering**

Type MEF switchgear with VCP-T circuit breakers can be supplied with external relays, such as Eaton's EDR-3000, EDR-5000 and EMR-3000, and meters such as Eaton's Power Xpert Meter family. The external relays and meters are typically installed on the circuit breaker or control compartment doors and connected into the secondary circuits of conventional CTs and VTs. External control power may be required for correct operation of the external relays depending on the type of relays used.

Eaton's EDR-3000 is a microprocessor-based multifunction overcurrent protection relay designed to provide the following ANSI protection functions:

51/50, 51N/50N or 51G/50G.

EDR-3000 relays can be zone interlocked for faster selective tripping. Refer to **Tab 4** for more details of EDR-3000.

Eaton's EDR-5000 is a microprocessor-based multifunction protection and metering unit designed to provide the following ANSI protection functions:

51/50, 51N/50N, 51G/50G, 50BF, 25, 32, 46, 67, 27, 59, 47, 78V, 81-O, 81-U, 86.

The EDR-5000 can be zone interlocked for faster selective tripping. It can also be used for automatic open or closed transition transfer of three breaker main-tie-main systems. Refer to **Tab 4** for more details of the EDR-5000.

Eaton's EMR-3000 is a microprocessor-based motor protection relay designed to provide the following ANSI protection functions:

49, 50, 51, 46, 50G, 51G, 37, 38, 66, 2/19, 74, 86.

Refer to **Tab 4** for more details of the EDR-3000.

Eaton's Power Xpert and IQ microprocessor-based metering and communication devices can be provided in MEF for use with conventional CTs and VTs. Refer to **Tab 3** for further information on these devices.

Partial Discharge Sensing and Monitoring for Switchgear



RFCT Sensor



InsulGard Relay (PD Monitoring)

Partial Discharge in Switchgear

Partial discharge is a common name for various forms of electrical discharges such as corona, surface tracking and discharges internal to the insulation. It partially bridges the insulation between the conductors. These discharges are essentially small arcs occurring in or on the surface of the insulation system when voltage stress exceeds a critical value. With time, airborne particles, contaminants and humidity lead to conditions that result in partial discharges. Partial discharges start at a low level and increase as more insulation becomes deteriorated. Examples of partial discharge in switchgear are surface tracking across bus insulation, or discharges in the air gap between the bus and a support, such as where a bus passes through an insulating window between the sections of the switchgear. If partial discharge process is not detected and corrected, it can develop into a full-scale insulation failure followed by an electrical fault. Most switchgear flashover and bus failures are a result of insulation degradation caused by various forms of partial discharges.

Sensing and Monitoring

Eaton’s Type MEF metal-enclosed switchgear (2.4–15 kV) is corona-free by design. By making switchgear assemblies corona-free, Eaton has made its standard switchgear more reliable. However, as indicated above, with time, airborne particles, contaminants and humidity lead to conditions that cause partial discharges to develop in switchgear operating at voltages 4000 V and above. Type MEF switchgear can be equipped with factory-installed partial discharge sensors and partial discharge sensing relay for continuous monitoring of the partial discharges under normal operation. Timely detection of insulation degradation through increasing partial discharges can identify potential problems so that corrective actions can be planned and implemented long before permanent deterioration develops. Partial discharge detection can be the foundation of an effective predictive maintenance program. Trending of partial discharge data over time allows prediction of failures, that can be corrected before catastrophic failure occurs.

The PD sensing and monitoring system consists of Eaton’s InsulGard™ relay and PD sensors specifically developed for application in the switchgear to work with the relay.

Partial discharges within the MEF switchgear compartment are detected by the installation of a small donut type radio frequency current transformer (RFCT) sensor over floating stress shields of the specially designed CT/sensor primary bushings. Partial discharges in the customer’s power cables (external discharges) are detected by the installation of the

RFCT around ground shields of the incoming or outgoing power cables termination.

Output signals from sensors (RFCTs) are wired out to terminal blocks for future or field use, or connected to the InsulGard relay. One InsulGard relay can monitor up to 15 output signals, including temperature and humidity. The temperature and humidity sensors are included with each InsulGard relay system.

The relay continuously monitors the switchgear primary system for partial discharges and provides an alarm signal (contact closure) when high PD level is detected. Data analysis and diagnostics by Eaton engineers can also be provided by remote communication with the InsulGard relay.

The sensors and InsulGard relay are optional in MEF switchgear.

In 5/15 kV MEF switchgear (refer to **Figure 6.0-4**), primary epoxy bushings with stress shield and RFCT sensors for measurement of internal, as well as external partial discharges are all optional. InsulGard relay is also optional. When specified, one set of CT/sensor primary bushings (located on the line side) with stress shield and associated RFCT sensor is provided in every incoming and outgoing primary circuit. An additional RFCT sensor for each incoming and outgoing power cable circuits can be provided as required. The RFCT output signals can be connected directly to InsulGard relay for continuous monitoring of partial discharges or can be used for periodic field measurements. One InsulGard relay can monitor up to 15 output signals.

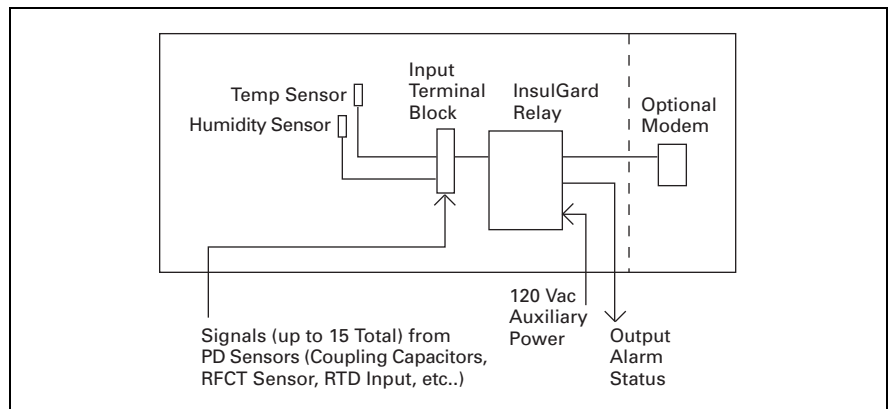

Figure 6.0-3. InsulGard Relay System

General Description—Partial Discharge Sensing and Monitoring

6

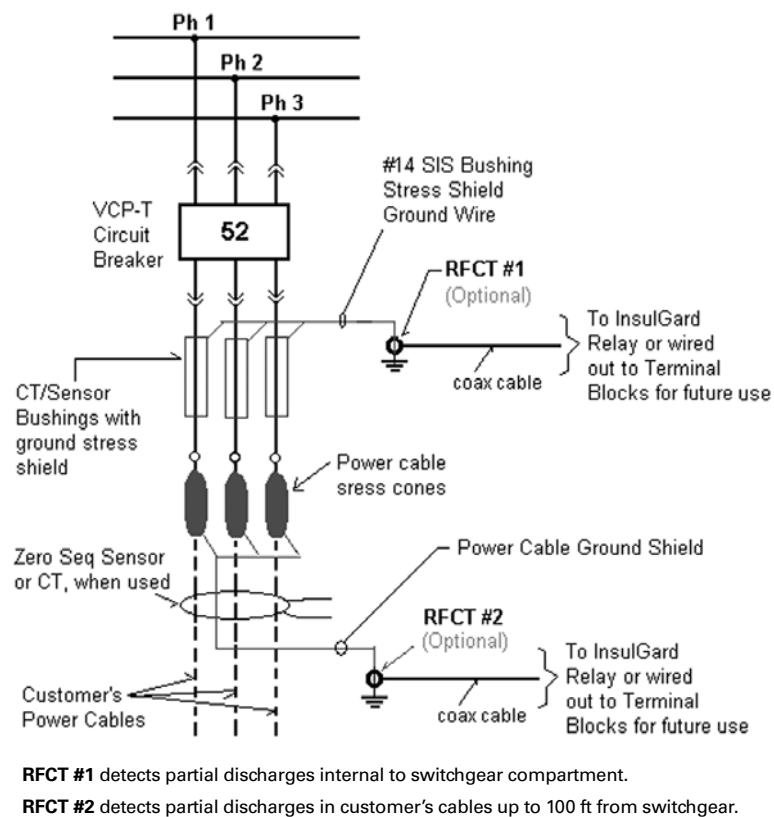

Figure 6.0-4. Typical Partial Discharge Sensor Connections in MEF Switchgear (5–15 kV)

Note: Use one set of CT/sensor bushings for all incoming and outgoing primary circuits.

General Description

Communication Systems

Eaton's power management products provide hardware and software solutions that allow customers to interface with their switchgear at varying levels of sophistication. Power Xpert and IQ Meters monitor common electrical parameters and communicate the data via standard industry protocols and optional Web interfaces. Power Xpert Gateways consolidate devices into a single Web browser interface and provide Ethernet connectivity. Eaton's Power Xpert Insight® and Foreseer Web-based software systems display, analyze and store data from multiple devices across the facility to enable management of the customer's power system. Refer to **Tab 2** for more information on communication systems.

Standard Accessories**Levering Crank**

Used for moving the breaker between the disconnected/test and connected position.

Breaker Extension Pan

Used for installing/removing the breaker to/from its compartment.

Breaker Lifting Yoke

Used with the breaker for installation/removal of the breaker onto/from the breaker extension pan using optional breaker lifter or other overhead lifting means.

Test Jumper

Allows connection of breaker secondary controls disconnect to cell disconnect when the breaker is outside its compartment.

VT/CPT Drawer Extension Rails

Allows withdrawal of VT/CPT auxiliary drawer for inspection and access to primary fuses and VT/CPT.

Optional Accessories**Breaker Lifting Device**

Used for installing/removing the breaker onto/from the Breaker Extension Pan.

Manual Ground and Test Device

The ground and test device is a drawout element that may be inserted into a breaker compartment in place of a circuit breaker to provide access to the primary circuits to permit the temporary connections of grounds or testing equipment to the high voltage circuits.

The device includes six terminals for connections to primary circuits. Selection of upper or lower terminals for grounding is accomplished manually by cable connections before the device is inserted into the desired breaker compartment. The circuit selected for grounding using this device must be checked by some other means, prior to insertion of the device into the compartment, to be sure it is de-energized.

High potential testing of cable or phase checking of circuits are typical tests that may be performed. The device is insulated to suit voltage rating of the switchgear and will carry required levels of short-circuit current, but it is not rated for any current interruption.

Before using a ground and test device, it is recommended that each user develop detailed operating procedure consistent with safe operating practices. Only qualified personnel should be authorized to use the ground and test device.

Dummy Element

Dummy element is a drawout element with primary disconnects similar to a drawout circuit breaker, but consists of solid copper conductors in place of vacuum interrupters, and is designed for manual racking. It is typically used as drawout disconnect link in the primary system for circuit isolation or bypass. The device is insulated to suit the voltage rating of the switchgear and will carry required levels of short-circuit current, but it is not rated for any current interruption. It must be key interlocked with all source devices such that it can only be inserted into or removed from its connected position only after the primary circuit that it is to be applied is completely de-energized.

Before using a dummy element, it is recommended that each user develop detailed operating procedure consistent with safe operating practices. Only qualified personnel should be authorized to use the dummy element.

Functional Test Kit (for Testing of Digitrip 520V and 1150V Relays)

Functional Test Kit is a hand-held battery powered tester capable of testing trip elements of 520V and 1150V protective relays. The test kit allows testing of: Relay Power Up, Instantaneous Trip, Short Delay Trip, Long Delay Pickup and Trip, and Ground Fault Trip, when applicable.

Application

MEF Switchgear with Automatic Transfer Control (ATC)**Application**

Eaton's MEF switchgear with an automatic transfer control system is an integrated assembly of drawout VCP-T/VCP-TL breakers, sensing devices and control components available in 5 through 15 kV classes.

Automatic transfer control is typically applied where the continuity of service for critical loads from two power sources in either a two-breaker (one load) or three-breaker (two loads) configuration is desired.

MEF switchgear with an automatic transfer control system can meet most automatic throwover requirements as it has a wide variety of operational sequences embodied in one standard automatic transfer control system.

ATC Controller

Eaton's ATC-900 controller is equipped to display history information either via the front panel or over the Power-Net power monitoring system. ATC-900 controller stores 320 time stamped events. Oscillographic data for last 10 events can be downloaded via USB port or displayed in the controller's display window. Controller allows communications via RS-232 or Modbus through RS-458 port, Ethernet or via USB interface.



ATC Controller

Standard Features

- Voltage sensing on both sources is provided by the ATC controller
- Lights to indicate status of switches, sources, and so on
- Interlocking to prevent paralleling of sources via software
- Control power for the automatic transfer control system is derived from the sensing voltage transformers
- Manual override operation
- Selectable closed with sync check or open transition on return to normal
- Programmable time delays on both sources, "OFF DELAY" and "ON DELAY"
- Four programmable digital inputs and outputs
- Single-source responsibility; all basic components are manufactured by Eaton

Optional Features

- Lockout on phase and/or ground overcurrents and/or internal bus faults
- Load current, power and PF metering with optional DCT module
- 24 Vdc control power input
- Up to four additional I/O modules, each with four programmable digital inputs and digital outputs

Typical Two-Breaker Automatic Transfer Control Using ATC Controller

Eaton's ATC controller continuously monitors all three phases on both sources for correct voltages. Should the voltage of the normal source be lost while the voltage of the alternate source remains normal, the voltage sensing function in the ATC controller will change state starting the time delay function. If the voltage of the normal source is not restored by the end of the time delay interval, the normal breaker will open and the alternate source breaker will close, restoring power to the load.

Typical Three-Breaker (Two Mains and Normally Open Tie) Automatic Transfer Control

The automatic transfer switchgear assembly includes two main breakers and one tie breaker, and an integrated automatic transfer control system containing sensing devices, low voltage logic control and auxiliary equipment. The transfer control system monitors both sources for correct voltages. An automatic-manual transfer selector switch is provided for selection of manual or automatic operating mode. In manual mode, all three breakers can be manually operated. Interlocking is provided in manual mode of operation to prevent closing all three breakers at the same time. In the automatic mode, the basic sequence of operation based upon two normally energized sources is carried out as follows. Normal operation is with the main breakers closed and the tie breaker open. Upon detection of an undervoltage(s) to the line side of a main breaker, and after a field-adjustable time delay, that main breaker opens and after an additional field-adjustable time delay, the tie breaker closes to restore power to the affected portion of the facility. Upon restoration of voltage to the line side of the main breaker, and after a field-adjustable time delay, the tie breaker opens and after a field-adjustable time delay, the opened main breaker closes. An interlocking is provided to prevent closing all three breakers simultaneously in manual mode.

Technical Data

Table 6.0-3. MEF Switchgear Assembly Rated Per ANSI Standards

Rated Maximum Voltage	Insulation Level		Rated Main Bus Continuous Current	Rated Short-Time Short-Circuit Current Withstand (2-Second)	Rated Momentary Short-Circuit Current Withstand (10 Cycle)	
	Power Frequency Withstand Voltage, 60 Hz, 1 Minute	Impulse Withstand Voltage (BIL)			I	1.55 * I (for Reference Only)
kV rms	kV rms	kV Peak	Amperes	kA rms Symmetrical	kA Crest	kA rms Asymmetrical
4.76	19	60	1200	25	65	39
4.76	19	60	2000	25	65	39
4.76	19	60	1200	40	104	62
4.76	19	60	2000	40	104	62
15	36	95	1200	25	65	39
15	36	95	2000	25	65	39
15	36	95	1200	40	104	62
15	36	95	2000	40	104	62

Table 6.0-4. Available Type VCP-T Vacuum Circuit Breakers Rated Per ANSI Standards (C37.04, C37.09) ①②

Circuit Breaker Type ①②	Rated Maximum Voltage	Insulation Level		Rated Continuous Current	Rated Short-Circuit Current at Rated Maximum Voltage	Rated Voltage Range Factor	Maximum Symmetrical Interrupting & 2-Second Short-Time Current Carrying Capability	Closing and Latching Capability (Momentary)	Cable Charging Breaking Current	Three-Phase MVA at Rated Maximum Voltage (for Reference Only)	Mechanical Endurance No Load C-O Operations
		Power Frequency Withstand Voltage, 60 Hz, 1 Minute	Impulse Withstand Voltage (BIL) 1.2 x 50 microsec								
		V	I								
kV rms	kV rms	kV Peak	Amperes	kA rms Symmetrical	kA rms Symmetrical	kA Crest	kA Crest	Amperes	MVA		
50VCP-T16	4.76	19	60	600	16	1	16	42	25	130	20,000
50VCP-T16	4.76	19	60	1200, 2000	16	1	16	42	25	130	10,000
50VCP-T20	4.76	19	60	600, 1200, 2000	20	1	20	52	25	165	10,000
50VCP-T25	4.76	19	60	600, 1200, 2000	25	1	25	65	25	210	10,000
50VCP-T32	4.76	19	60	600, 1200, 2000	31.5	1	31.5	82	25	260	10,000
50VCP-T40	4.76	19	60	600, 1200, 2000	40	1	40	104	25	330	10,000
150VCP-T16	15	36	95	600, 1200, 2000	16	1	16	42	25	420	10,000
150VCP-T20	15	36	95	600, 1200, 2000	20	1	20	52	25	520	10,000
150VCP-T25	15	36	95	600, 1200, 2000	25	1	25	65	25	650	10,000
150VCP-T32	15	36	95	600, 1200, 2000	31.5	1	31.5	82	25	830	10,000
150VCP-T40	15	36	95	600, 1200, 2000	40	1	40	104	25	1040	10,000

① Rated interrupting time for all VCP-T circuit breakers is 3 Cycle (50 ms).

② Operating duty for all VCP-T circuit breakers is O-0.3sec-CO-3min-CO.

Table 6.0-5. Type VCP-TC Circuit Breakers (Tested for Capacitor Switching) ③

Type VCP-TC circuit breakers have same ratings as type VCP-T circuit breakers, plus capacitor switching capabilities as follows:

Cable Charging	Grounded Capacitor Banks	
	Single Bank	Back-to-Back
25 A	250 and 1000 A	250 A with Inrush Current 4 kApk at 5.9 kHz and 1000 A with Inrush Current 15 kApk at 25 kHz

③ Type 50 VCP-T32C, 50 VCP-T40C, 150 VCP-T32C and 150 VCP-T40C circuit breakers only.

Note: Ratings of 250 and 1000 A cover capacitor bank applications from 75–1000 A. Type VCP-TC breakers are considered definite purpose breakers per ANSI C37.04.

Technical Data

Table 6.0-6. Available Type VCP-TL Vacuum Circuit Breakers Rated Per ANSI Standards (C37.04, C37.09) ①②

Circuit Breaker Type ①②	Rated Maximum Voltage	Insulation Level		Rated Continuous Current	Rated Short-Circuit Current at Rated Maximum Voltage	Rated Voltage Range Factor	Maximum Symmetrical Interrupting & 2-Second Short-Time Current Carrying Capability	Closing and Latching Capability (Momentary)	Cable Charging Breaking Current	Three-Phase MVA at Rated Maximum Voltage (for Reference Only)	Mechanical Endurance No Load C-O Operations									
		Power Frequency Withstand Voltage 60 Hz, 1 Minute	Impulse Withstand Voltage (BIL) 1.2 x 50 microsec								Amperes	kA rms Symmetrical	K	K * I	2.6 * K * I	Amperes	1.732 * V * I	MVA	Vacuum Interrupter	Mechanism
		kV rms	kV Peak																	
50VCP-TL16	4.76	19	60	600, 1200	16	1	16	42	25	130	30,000	100,000								
50VCP-TL20	4.76	19	60	600, 1200	20	1	20	52	25	165	30,000	100,000								
50VCP-TL25	4.76	19	60	600, 1200	25	1	25	65	25	210	30,000	100,000								
150VCP-TL16	15	36	95	600, 1200	16	1	16	42	25	420	30,000	100,000								
150VCP-TL20	15	36	95	600, 1200	20	1	20	52	25	520	30,000	100,000								
150VCP-TL25	15	36	95	600, 1200	25	1	25	65	25	650	30,000	100,000								

① Rated interrupting time for all VCP-TL circuit breakers is **3 Cycle (50 ms)**.

② Operating duty for all VCP-TL circuit breakers is **O-0.3sec-CO-3min-CO**.

Table 6.0-7. Type VCP-TLC Circuit Breakers (Tested for Capacitor Switching)

Type VCP-TLC circuit breakers have same ratings as type VCP-TL circuit breakers, plus capacitor switching capabilities as follows:

Cable Charging	Grounded Capacitor Banks	
	Single Bank	Back-to-Back
25 A	250 and 630 A	250 A with inrush current 15 kApk at 5 kHz and 630 A with inrush current 15 kApk at 1.5 kHz

Note: Ratings of 250 and 630 A cover capacitor bank applications from 75 to 630 A.

Note: Type VCP-TLC breakers are considered definite purpose breakers per ANSI C37.04.

Switchgear Heat Loss

The heat-loss data for circuit breakers given in **Table 6.0-8** includes portion of main bus conductors and load run-backs. Please note that the estimated wattage given for each component is at its full rating. For example, the chart shows 600 W for 1200 A breaker. It simply means an estimated 600 W loss in breaker in a 1200 A, 5/15 kV compartment when the circuit breaker is carrying full 1200 A. The actual loss, of course, will depend on the actual current being carried by the breaker. If the full load current of the load connected to that 1200 A breaker, for example, is only 200 A, the heat-loss in that compartment will be much less. By simple "I x I x R" calculations, one can easily calculate actual loss at 200 A as = 600 x (200/1200) x (200/1200) = 16.67 W. Also, in case of lineup consisting of many feeders, all feeders might not be carrying or supplying loads at all times. If that is the case, then one can further reduce total watt loss for the lineup by applying a utilization factor.

Table 6.0-8. MEF Equipment Losses

Equipment	Watts Loss
Medium Voltage Switchgear (Indoor, 5 and 15 kV)	
600 A breaker	400
1200 A breaker	600
2000 A breaker	1400

Type VCP-T Circuit Breaker Operating Times

The closing time (initiation of close signal to contact make) and opening time (initiation of the trip signal to contact break) are shown in **Table 6.0-9**. **Figure 6.0-5** below shows the sequence of events in the course of circuit interruption, along with applicable VCP-T circuit breaker timings.

Table 6.0-9. Closing and Opening Times for Electrically Operated VCP-T Breakers, at Rated Control Voltage

Rated Control Voltage	Breaker Rating	Closing Time Milliseconds	Opening Time Milliseconds ^①
48 V, 125 V, 250 Vdc	All	28–40	17–27
120 V, 240 Vac	All	28–40	—
120 V or 240 Vac capacitor trip	All	—	17–27
Optional—undervoltage trip release 48 V, 125 V, 250 Vdc	All	—	40–60

^① For manually operated breakers with integral protective relay, refer to applicable relay time-current curves for clearing time.

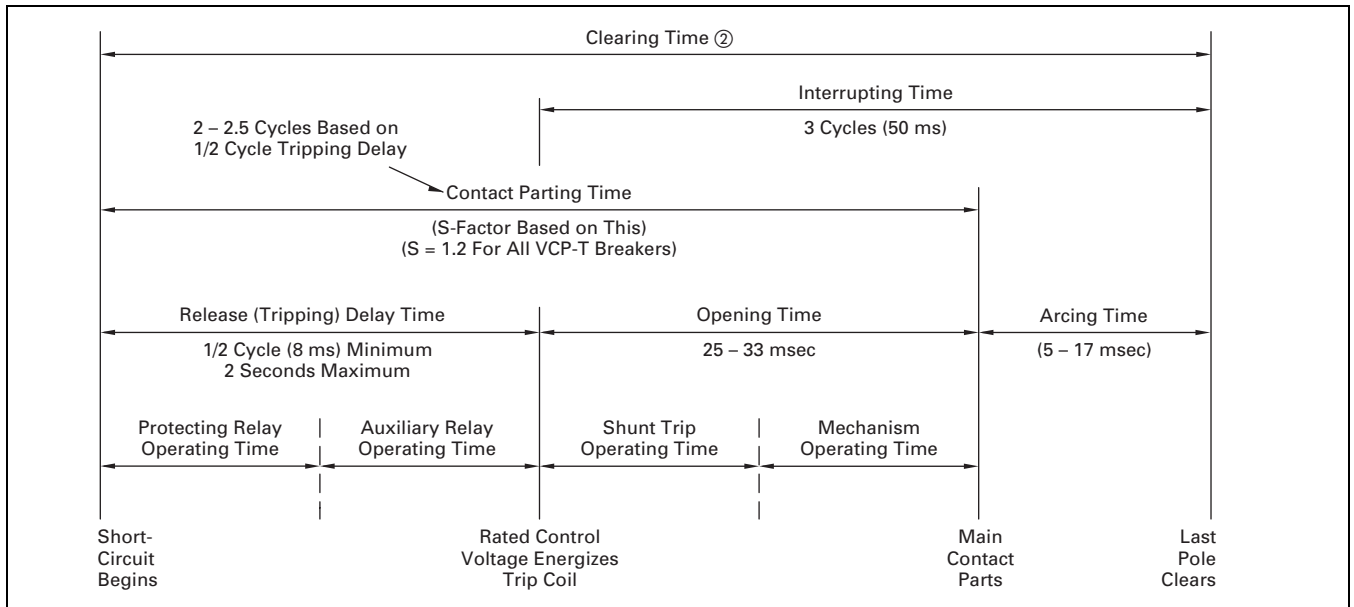

Figure 6.0-5. Sequence of Events for VCP-T Circuit Breakers with Shunt Trip

^② For manually operated breakers with integral protective relay, refer to applicable relay time-current curves for clearing time.

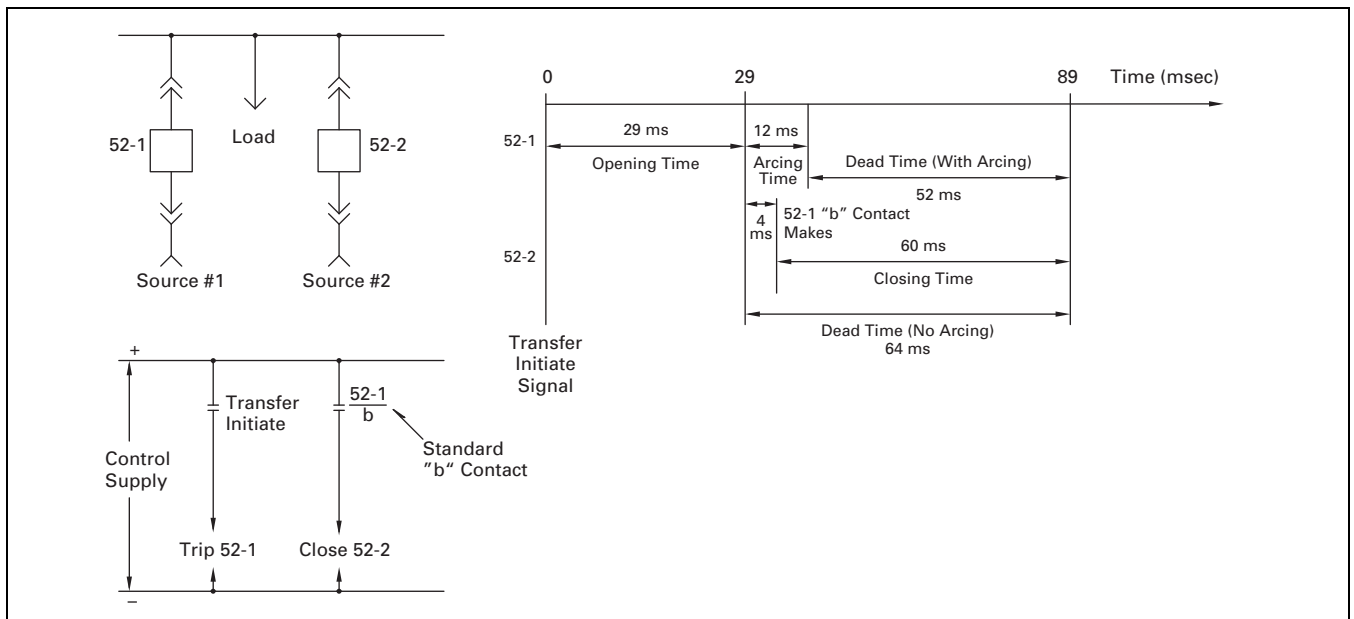

Figure 6.0-6. Typical Transfer Times—Fast Sequential Transfer—VCP-T Circuit Breakers

Technical Data—Circuit Breakers

Type VCP-TL Circuit Breaker Operating Times

The closing time (initiation of close signal to contact make) and opening time (initiation of the trip signal to contact break) are shown in **Table 6.0-10**. **Figure 6.0-7** below shows the sequence of events in the course of circuit interruption, along with applicable VCP-TL circuit breaker timings.

Table 6.0-10. Closing and Opening Times for Electrically Operated VCP-TL Breakers, at Rated Control Voltage, Typical

Rated Control Voltage	Breaker Rating	Closing Time Milliseconds	Opening Time Milliseconds ①
36–60 Vac, 36–72 Vdc	All	60	25–33
100–240 Vac, 100–353 Vdc	All	60	25–33

① For manually operated breakers with integral protective relay, refer to applicable relay time-current curves for clearing time.

6

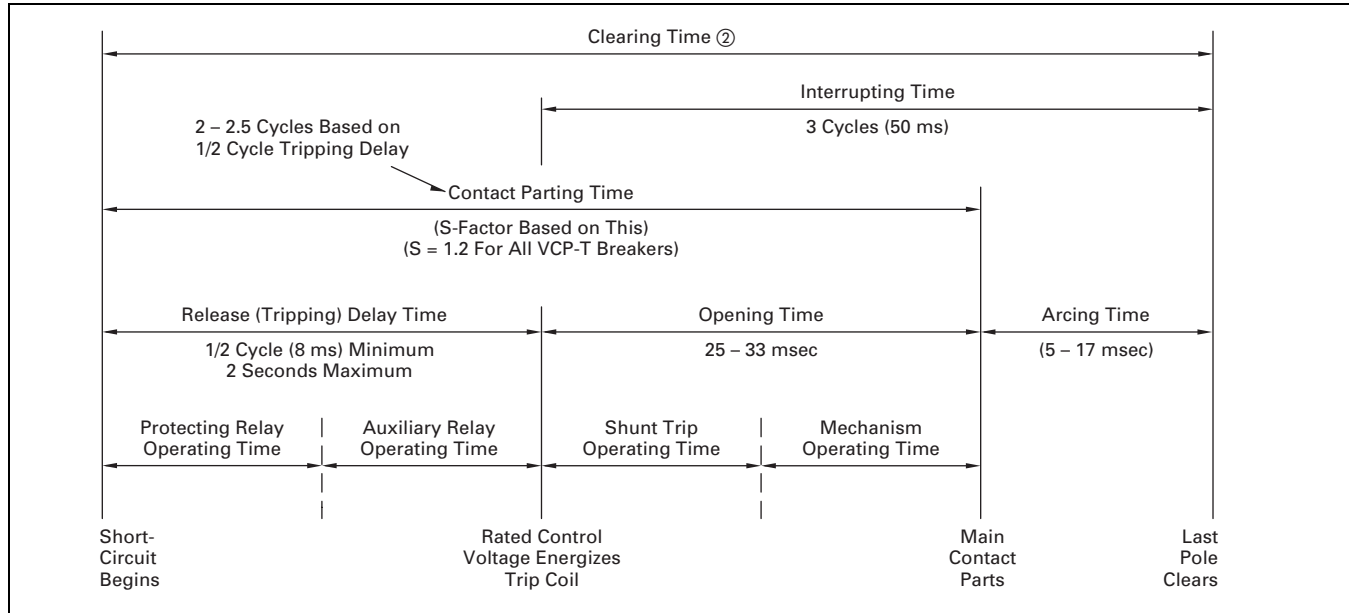

Figure 6.0-7. Sequence of Events for VCP-TL Circuit Breakers with Shunt Trip

② For manually operated breakers with integral protective relay, refer to applicable relay time-current curves for clearing time.

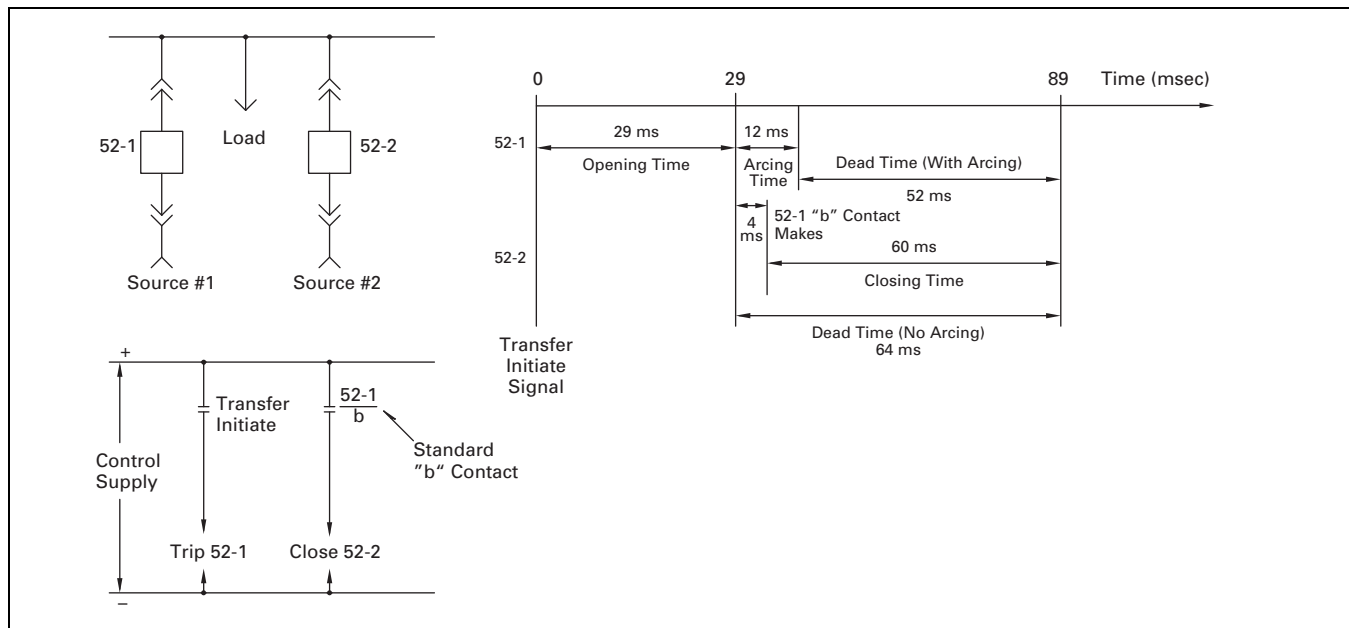

Figure 6.0-8. Typical Transfer Times—Fast Sequential Transfer—VCP-TL Circuit Breakers

Table 6.0-11. Shunt Trip Coil Ratings, VCP-T Breakers ①

Rated Control Voltage	Operational Voltage Range	Inrush Power Consumption at Rated Voltage	Remark
	Volts		
24 Vdc	14–28	250	—
48 Vdc	28–56	250	—
110 Vdc	77–121	450	—
125 Vdc	70–140	450	—
220 Vdc	154–242	450	—
250 Vdc	140–280	450	—
110 Vac	77–121	450	Capacitor Trip
120 Vac	104–127	450	Capacitor Trip
220 Vac	154–242	450	Capacitor Trip
240 Vac	208–254	450	Capacitor Trip

① These electrical accessories are optional for VCP-T circuit breaker, and require external control power. Please specify each of these accessories as required for the application.

Table 6.0-12. Spring Release Coil (Closing Coil) Ratings, VCP-T Breakers ②

Rated Control Voltage	Operational Voltage Range	Inrush Power Consumption at Rated Voltage
	Volts	
24 Vdc	20–27	250
48 Vdc	38–56	250
110 Vdc	94–121	450
125 Vdc	100–140	450
220 Vdc	187–242	450
250 Vdc	200–280	450
110 Vac	94–121	450
120 Vac	104–127	450
220 Vac	187–242	450
240 Vac	208–254	450

② These electrical accessories are optional for VCP-T circuit breaker, and require external control power. Please specify each of these accessories as required for the application.

Table 6.0-15. VCP-TL Circuit Breaker Control Power Requirements

Rated Control Voltage	Electro-Magnetic Controller Internal Capacitors Charging ⑤				Minimum Close, Carry and Interrupting Current Ratings Needed for External Contacts	
	Maximum Inrush Peak	Inrush Duration	Charging Current Peak	Maximum Charging Duration	Close Contact	Trip Contact
	A	ms	A	Sec.		
48 Vdc	0.52	3.5	1	30	11 mA at 96 Vdc	4 mA at 96 Vdc
125 Vdc	14	3.5	1	30	11 mA at 96 Vdc	4 mA at 96 Vdc
250 Vdc	22	3.5	1	30	11 mA at 96 Vdc	4 mA at 96 Vdc
120 Vac	17	3.5	1	30	11 mA at 96 Vdc	4 mA at 96 Vdc
240 Vac	22	3.5	1	30	11 mA at 96 Vdc	4 mA at 96 Vdc

⑤ Data provided are for charging of internal capacitors from a fully discharged state. In normal operation, the capacitors recharge in about 15 seconds after each closing operation.

Table 6.0-13. Undervoltage Release Coil Ratings, VCP-T Breakers ③

Rated Control Voltage	Operational Voltage Range	Dropout Voltage Range (35–60%)	Inrush Power Consumption	Continuous Power Consumption at Rated Voltage
	Volts			
24 Vdc	20–26	8–14	250	18
48 Vdc	41–53	17–29	275	18
110 Vdc	94–121	39–66	450	10
125 Vdc	106–138	44–75	450	10
220 Vdc	187–242	77–132	450	10
250 Vdc	213–275	88–150	450	10
110 Vac	94–121	39–66	450	10
120 Vac	102–132	42–72	450	10
220 Vac	187–242	77–132	400	10
240 Vac	204–264	84–144	400	10

③ These electrical accessories are optional for VCP-T circuit breaker, and require external control power. Please specify each of these accessories as required for the application.

Table 6.0-14. Spring Charging Motor Ratings, VCP-T Breakers ④

Rated Control Voltage	Operational Voltage Range	Running Current	Inrush Current	Power Consumption at Rated Voltage	Spring Charging Time
		Ampere	Ampere		Seconds
24 Vdc	20–27	8	32	250	5
48 Vdc	38–56	4	16	250	5
110 Vdc	94–121	3	12	250	5
125 Vdc	100–140	3	12	250	5
220 Vdc	187–242	2	8	250	5
250 Vdc	200–280	2	8	250	5
110 Vac	94–121	3	12	250	5
120 Vac	104–127	3	12	250	5
220 Vac	187–242	2	8	250	5
240 Vac	208–254	2	8	250	5

④ These electrical accessories are optional for VCP-T circuit breaker, and require external control power. Please specify each of these accessories as required for the application.

Breaker Auxiliary Switch

All VCP-T/VCP-TL circuit breakers are supplied with an auxiliary switch with 5NO and 5NC contacts. On Manually Operated breakers, all 5NO and 5NC contacts are available for customer's use. On Electrically Operated circuit breakers, 1NO and 1NC contacts are used for breaker status indicating lights (red and green lights) and remaining 4NO and 4NC contacts are generally available for other control functions or customer's use.

The auxiliary switch is a heavy-duty, double-break type switch with wipe type contacts. The switch contact ratings and operating times are given in **Table 6.0-16** and **Figure 6.0-9**.

6

MOC Switch

The mechanism operated cell (MOC) switch is not available in MEF switchgear. When number of NO and NC contacts available from the Breaker Auxiliary Switch are not sufficient for controls or customer's use, an auxiliary relay energized by one of the available NO or NC contacts must be used as needed. The use of auxiliary relay requires external control power.

TOC Switch

The optional truck operated cell (TOC) switch operates when the circuit breaker is levered into or out of the operating (connected) position. In MEF TOC option includes two micro switches, one for connected position, and one for test/disconnected position, each with 1 Form C contact. If additional contacts are required, auxiliary relay must be used. The use of auxiliary relay requires external control power. The TOC switch contact ratings are given in **Table 6.0-17**.

Table 6.0-16. Breaker Auxiliary Switch Contact Ratings

Continuous Current in Amperes	Control Circuit Voltage					
	120 Vac	240 Vac	24 Vdc	48 Vdc	125 Vdc	250 Vdc
Non-Inductive Circuit Interrupting Capacity in Amperes						
20	15	10	16	16	10	5
Inductive Circuit Interrupting Capacity in Amperes						
20	15	10	16	16	10	5

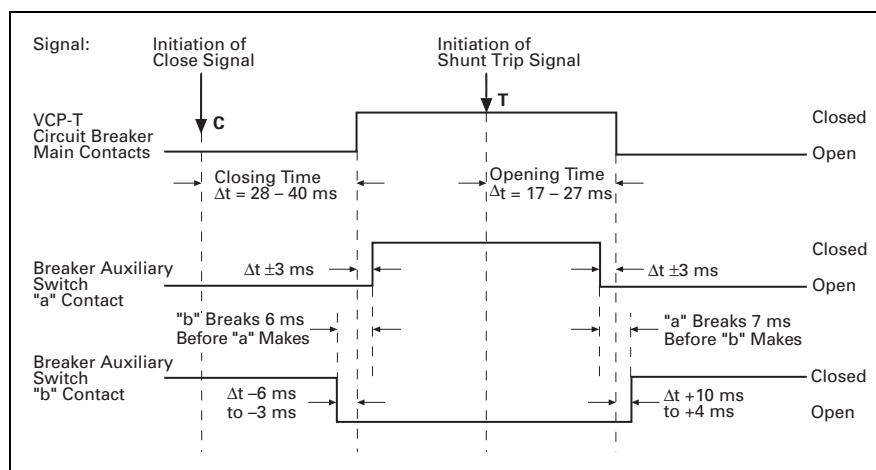

Figure 6.0-9. Breaker Auxiliary Switch Operating Times, at Rated Control Voltage

Table 6.0-17. TOC Switch Contact Ratings

Continuous Current in Amperes	Control Circuit Voltage					
	120 Vac	240 Vac	24 Vdc	48 Vdc	125 Vdc	250 Vdc
Non-Inductive Circuit Interrupting Capacity in Amperes						
20	15	15	6	0.5	0.5	0.2
Inductive Circuit Interrupting Capacity in Amperes						
20	12.5	12.5	5	0.05	0.05	0.03

Phase Current Sensors

Eaton Type-V phase current sensors are specifically designed and tested to function with Eaton’s 520V and 1150V integral protective relays and the Type VCP-T/VCP-TL circuit breaker.

The phase current sensors are installed in the primary circuit, external to the circuit breaker, over a set of specially designed insulated bushings. The bushings and current sensors are tested as an assembly for the same impulse withstand (BIL) rating as that of the switchgear in which they are installed.

The power required to operate the relay’s basic overcurrent protection functions is provided by secondary output from the current sensors once the three-phase primary current through the circuit breaker exceeds approximately 10 to 12% of the current sensor rating or single-phase primary current exceeds approximately 30% of the current sensor rating.

The current sensors are designed to supply sensing and operating power to Eaton’s 520V and 1150V integral protective relays. They are not suitable for use with any other relays or meters.

Primary current rating of the current sensors defines maximum continuous current rating (I_n) of the primary circuit in which they are installed, regardless of the circuit breaker frame rating. For example, an 800 A current sensor installed in a primary circuit controlled by 1200 A rated circuit breaker, defines 800 A as the maximum continuous current that can be carried through that circuit. The current sensors also determine the maximum instantaneous setting that can be set on the relays.

Phase Current Sensors and Rating Plugs—Available Ratings

- 100, 200, 250, 300, 400, 600, 630, 800, 1000, 1200, 1250, 1600 and 2000

Zero Sequence Current Sensors

Eaton Type-V zero sequence current sensors are specifically designed and tested to function with Eaton’s 520V and 1150V integral protective relays and type VCP-T/VCP-TL circuit breaker. The zero sequence sensor, as its name implies, measures zero sequence current (vector summation of phase currents) and provides sensitive method for ground fault sensing. Refer to **Table 6.0-18** for available zero sequence sensors.

Table 6.0-18. Zero Sequence Current Sensors—Available Ratings

Description	Ratio
ID = 4.80 inch (121.9 mm)	50:1 ①
(tap selectable), ID = 4.80 inch (121.9 mm)	100/200:1

① For use with 1150V relay only and with auxiliary power to the relay.

Phase and Zero Sequence Current Transformers

Conventional current transformers with 5A secondary are used when using external relays. CTs used for phase protection and metering are installed over the specially designed insulated bushings in the primary circuit. Maximum of two sets of CTs, or one set of CT and one set of current sensor can be installed over those insulated bushings. Ground fault sensing, when used, can be accomplished by residual sensing of phase currents, or by using an optional zero sequence current transformer. Refer to **Table 6.0-19** for the available current transformers and their ratings and accuracies.

Table 6.0-19. Phase and Zero Sequence Current Transformers—Available Ratings

CT Ratio	Metering Accuracy Classification at 60 Hz					Relay Class
	Burden B 0.1	Burden B 0.2	Burden B 0.5	Burden B 0.9	Burden B 1.8	
50:5	1.2	2.4	—	—	—	—
100:5	0.6	0.6	1.2	2.4	4.8	C10
200:5	0.6	0.6	0.6	1.2	2.4	C20
250:5	0.3	0.6	0.6	1.2	1.2	C20
300:5	0.3	0.3	0.3	0.6	1.2	C20
400:5	0.3	0.3	0.3	0.3	0.6	C50
500:5	0.3	0.3	0.3	0.3	0.3	C50
600:5	0.3	0.3	0.3	0.3	0.3	C100
750:5	0.3	0.3	0.3	0.3	0.3	C100
800:5	0.3	0.3	0.3	0.3	0.3	C100
1000:5	0.3	0.3	0.3	0.3	0.3	C100
1200:5	0.3	0.3	0.3	0.3	0.3	C100
1500:5	0.3	0.3	0.3	0.3	0.3	C100
1600:5	0.3	0.3	0.3	0.3	0.3	C100
2000:5	0.3	0.3	0.3	0.3	0.3	C100 ②
50:5 Zero sequence	—	—	—	—	—	C10
100:5 Zero sequence	—	—	—	—	—	C20

② This accuracy is less than IEEE C37.20.2.

Voltage Transformers

Voltage transformers supply voltage signal proportional to primary circuit voltage for relaying and metering. Refer to **Table 6.0-20** for available VT ratings and accuracies.

When two VTs are used, they are typically connected L-L, and provide phase-to-phase voltages, (Vab, Vbc, Vca) for metering and relaying.

When three VTs are used, they are connected line-to-ground, and provide phase-to-phase (Vab, Vbc, Vca), as well as phase-to-ground (Va, Vb, Vc) voltages for metering and relaying.

If metering or relaying application requires phase-to-ground voltages, use three VTs, each connected L-G. If not, use of two VTs connected L-L is sufficient.

For ground detection, three VTs connected in line-to-ground/broken-delta are used.

A single VT, when used, can be connected line-to-line (it will provide line-to-line output, for example Vab or Vbc, or Vca), or line-to-ground (it will provide line-to-ground output, for example Va or Vb or Vc). Generally, a single VT is used to derive voltage signal for synchronizing or Over Voltage/Under Voltage function.

Technical Data—Circuit Breaker Control, CPT and Surge Protection

**Table 6.0-20. Voltage Transformers—
Available Ratings** ①

Primary Voltage	Ratio	Secondary Voltage
2400	20:1	120
4200	35:1	120
4800	40:1	120
7200	60:1	120
8400	70:1	120
12000	100:1	120
12480	104:1	120
13200	110:1	120
14400	120:1	120

① All voltage transformers are rated for metering accuracy of 0.3% at 10 VA burden, and rated for thermal VA of 200 at 55 degrees C.

Circuit Breaker Control

VCP-T Circuit Breakers

Type VCP-T circuit breakers are available as either Manually Operated (MO) or Electrically Operated (EO). All circuit breakers are equipped with spring charging handle integral to the circuit breaker, and push-to-close and push-to-open pushbuttons.

Manually charging the closing springs and then pressing the push-to-close pushbutton accomplish closing of the MO breaker. Closing of the breaker charges the tripping springs. Manually pressing the push-to-open pushbutton accomplishes tripping of the MO breaker. If the MO breaker is equipped with integral protective relay, the relay provides tripping impulse via trip actuator to open the breaker, without a need for external control power supply.

Electrically operated breakers are equipped with electric motor for spring charging, spring release coil (close coil) and shunt trip coil. All EO breakers can be manually operated as described above. In order to electrically operate the EO breakers, external control power is required.

Also, when using microprocessor-based or solid-state external relays, external control power is required for relay logic.

For AC control, a capacitor trip device is used with each circuit breaker shunt trip to ensure energy is available for tripping during fault conditions. When AC control power is derived from within the switchgear, CPT should be connected on line side of the main breaker. For main-tie-main lineups, CPT connected on source side of each main with automatic transfer control device on the secondary should be used.

VCP-TL Circuit Breakers

All VCP-TL circuit breakers are equipped with linear actuator mechanism, comprising of: the linear actuator, electro-magnetic controller (EM controller), three closing capacitors, and internal power supply modules for the EM controller. An AC or DC control supply (selected by breaker style number) is required to operate the linear actuator mechanism. Internal power supply modules convert input control voltage and supplies 96 Vdc for operation of the EM controller and charging of capacitors. The linear actuator mechanism is designed for OCO duty cycle with control power on. Initial charging of capacitors (from fully discharged state) takes about 30 seconds. In normal operation with control power connected, the capacitors recharge in about 15 seconds after each closing operation. All circuit breakers include a standard anti-pump feature.

Once the capacitors are charged, circuit breaker can be closed and opened through: the use of manual ON and OFF pushbuttons mounted on the breaker itself, control switch mounted on the breaker compartment door, or any external dry contacts. In the event that control power is lost, the circuit breaker is capable of performing a manual or electrical OPEN operation up to 48 hours after the loss of control power. If the control power loss lasts longer than 48 hours, the circuit breaker can be opened using the integral EMERGENCY OPEN handle located on the front of the circuit breaker, by grasping the handle firmly and then pulling down.

Control Power Transformers

Control power transformer is used for auxiliary power for space heaters, light, receptacle and control of electrically operated breakers when external auxiliary power source is not available. Control power transformer when used for control of electrically operated breakers should be connected on source side of the main breaker so that the control power is available to close the main breaker. Refer to **Table 6.0-21** for available control power transformer ratings in MEF switchgear.

**Table 6.0-21. Control Power Transformers—
Available Ratings, Single-Phase, 60 Hz** ②

Voltage		kVA Rating	BIL kV
Primary	Secondary		
2400 V	240/120 V	5	60
4000 V	240/120 V	5	60
4160 V	240/120 V	5	60
4800 V	240/120 V	5	95
6900 V	240/120 V	5	95
7200 V	240/120 V	5	95
8320 V	240/120 V	5	95
8400 V	240/120 V	5	95
11500 V	240/120 V	5	95
12000 V	240/120 V	5	95
12470 V	240/120 V	5	95
13200 V	240/120 V	5	95
13800 V	240/120 V	5	95
14400 V	240/120 V	5	95

② Line-to-Line connection only available.

Surge Protection

Surge arresters and or surge capacitors can be provided in MEF switchgear. Refer to **Tab 5** for surge protection guidelines and recommended ratings.

Typical Three-Line Diagrams, Integral Protection

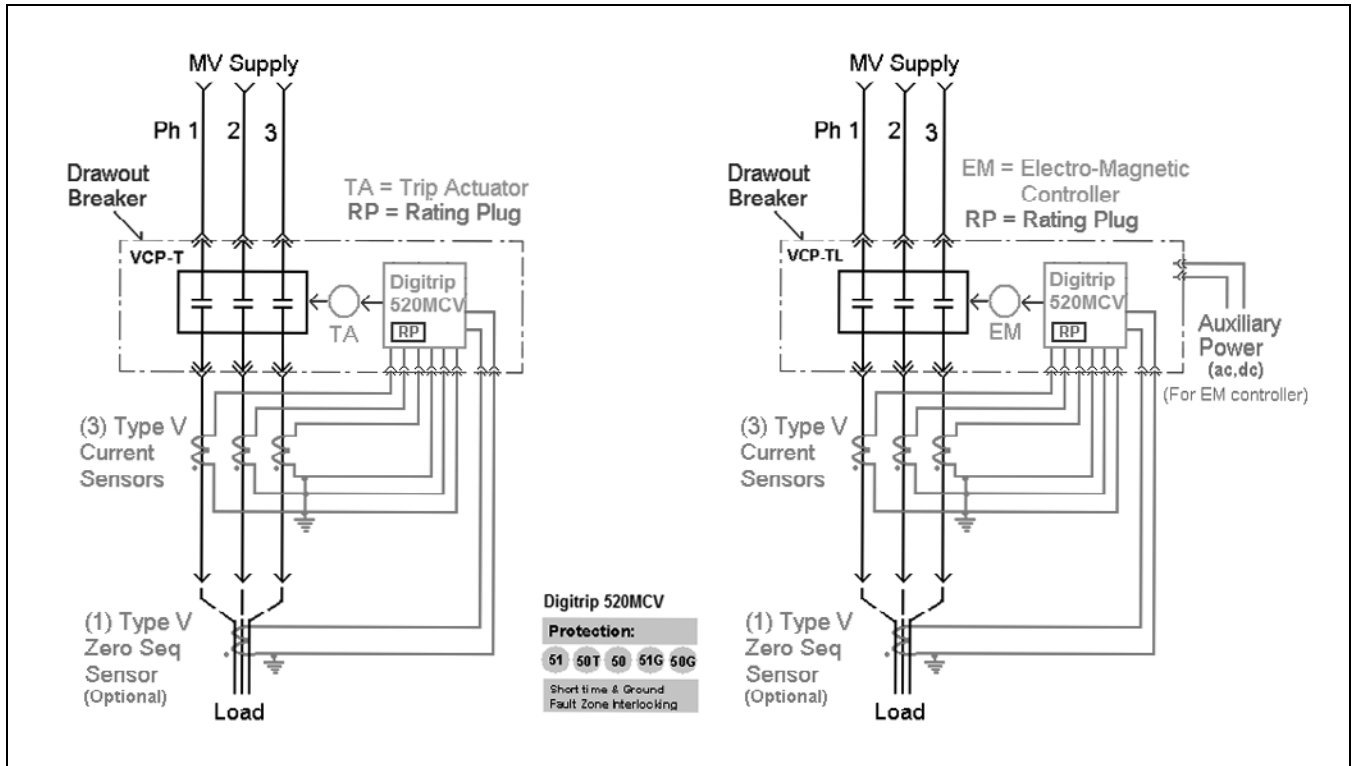

6

Figure 6.0-10. Typical MEF Switchgear with Digitrip 520MCV Integral Protective Relay

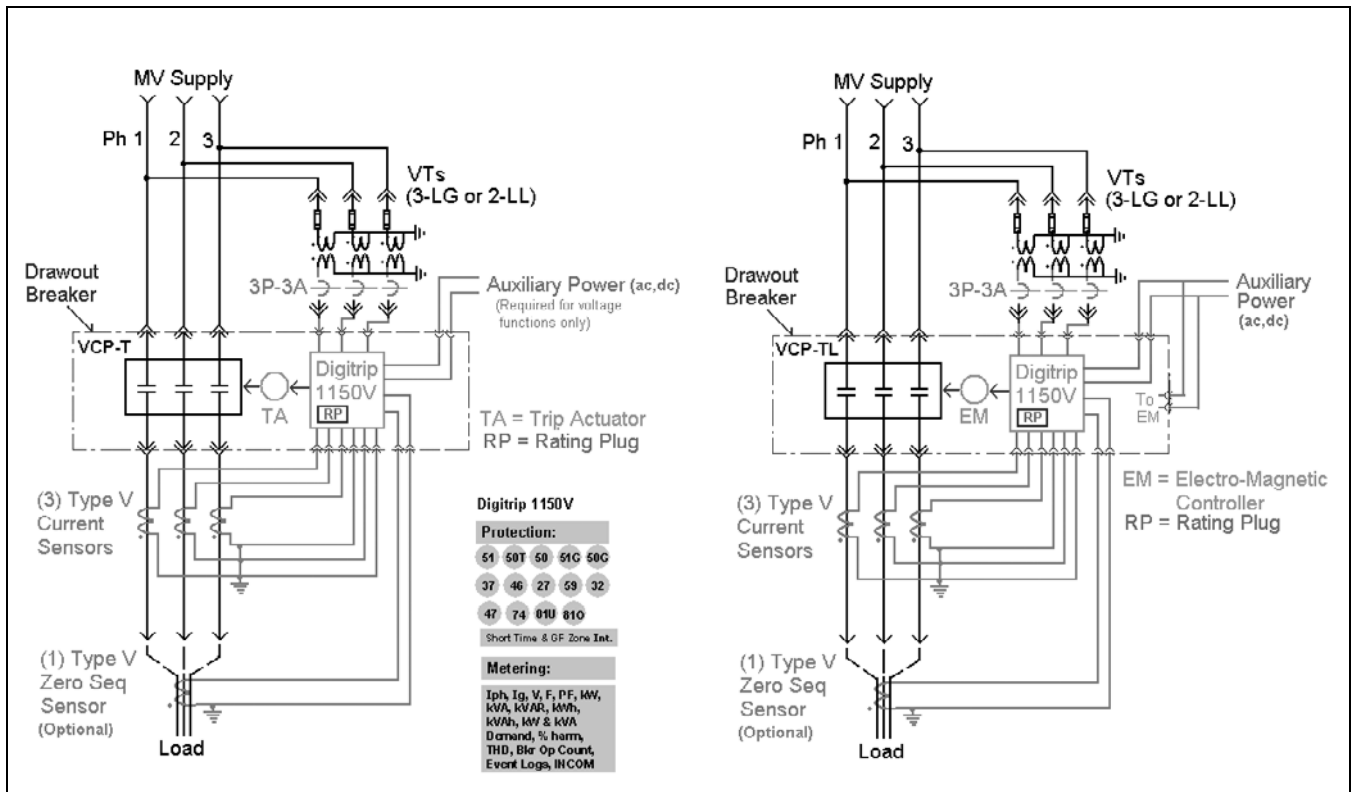

Figure 6.0-11. Typical MEF Switchgear with Digitrip 1150V Integral Protective Relay

Typical Three-Line Diagrams, External Protection

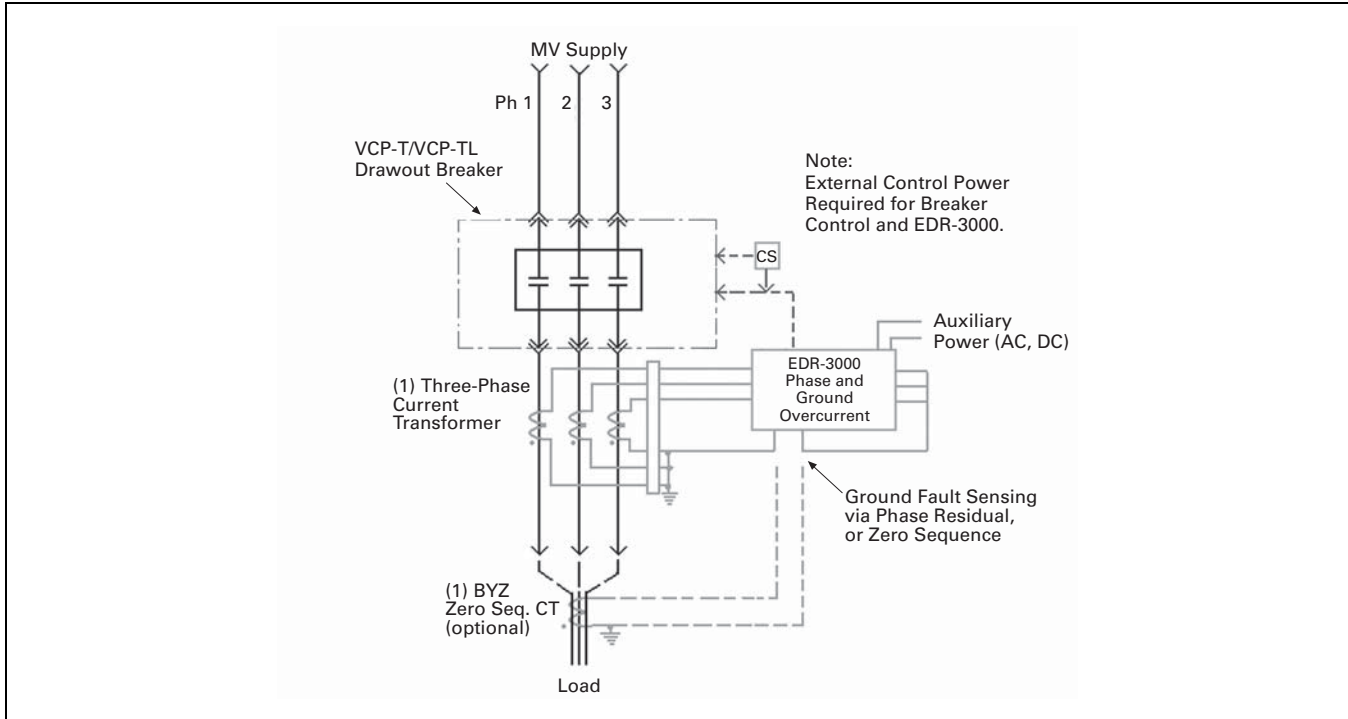

Figure 6.0-12. Typical MEF Switchgear with EDR-3000 Overcurrent Protective Relay

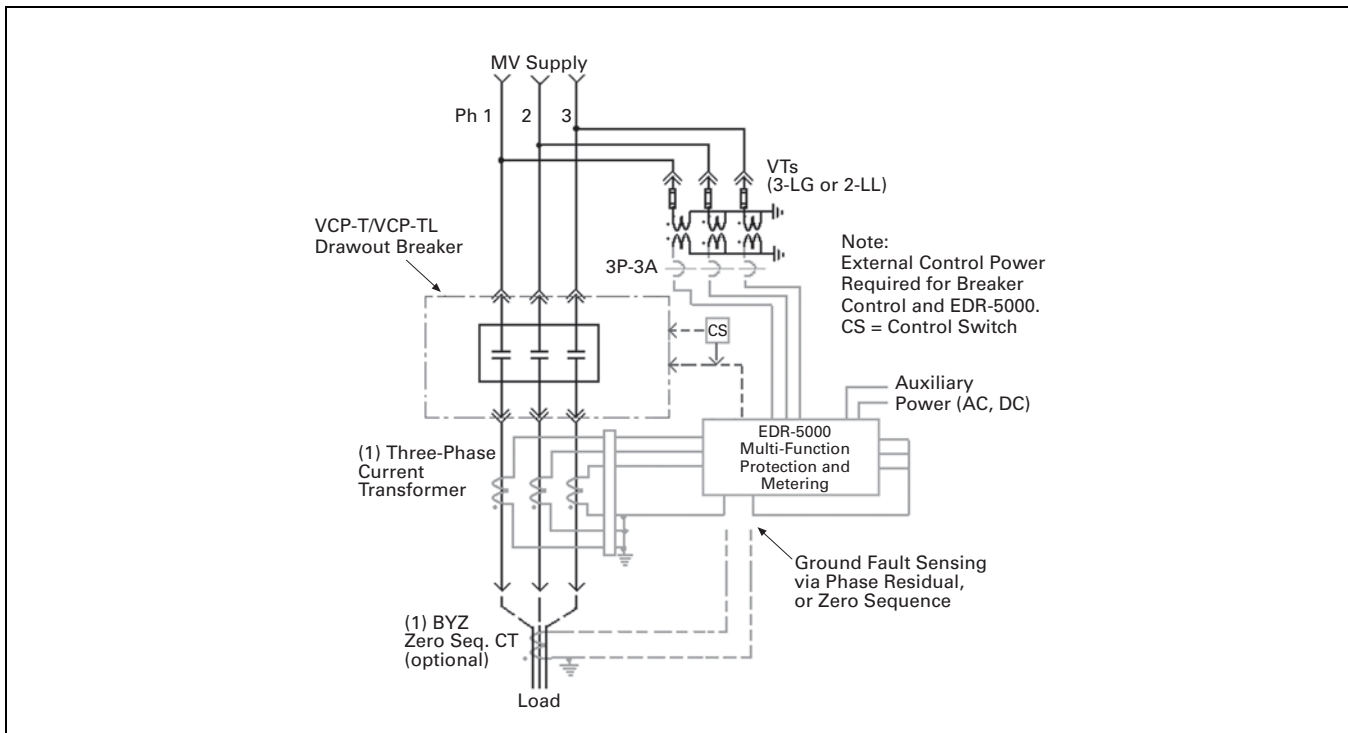

Figure 6.0-13. Typical MEF Switchgear with EDR-5000 Multi-Function Protective Relay

Technical Data

Electrically Operated Breakers—Control Schemes

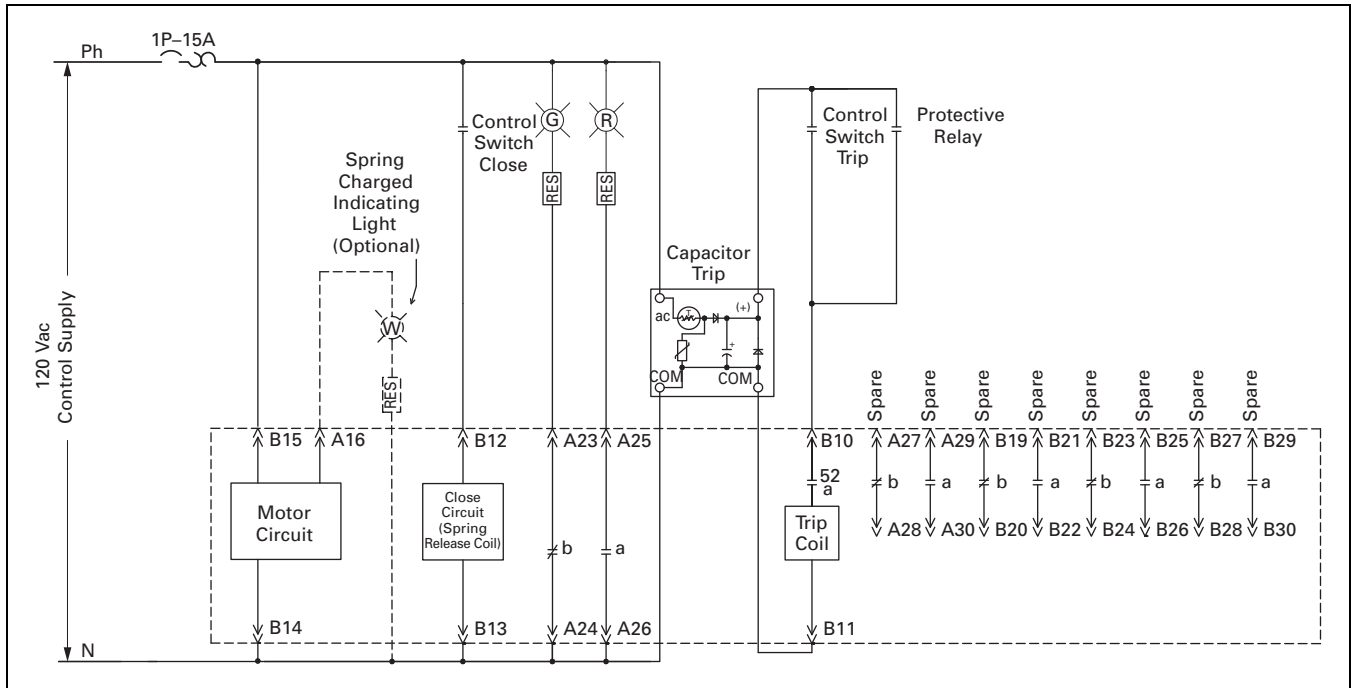

Figure 6.0-14. Typical AC Control Circuit—VCP-T Breaker

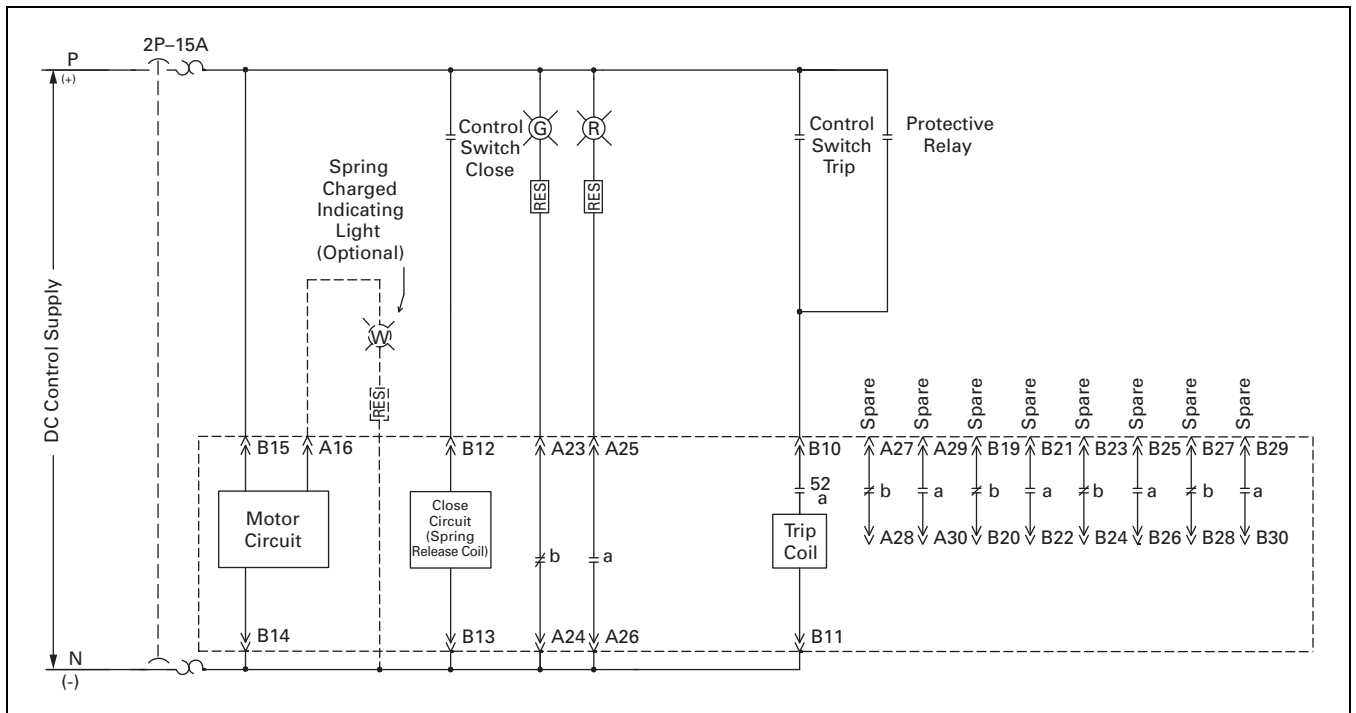

Figure 6.0-15. Typical DC Control Circuit—VCP-T Breaker

Electrically Operated Breakers—Control Schemes

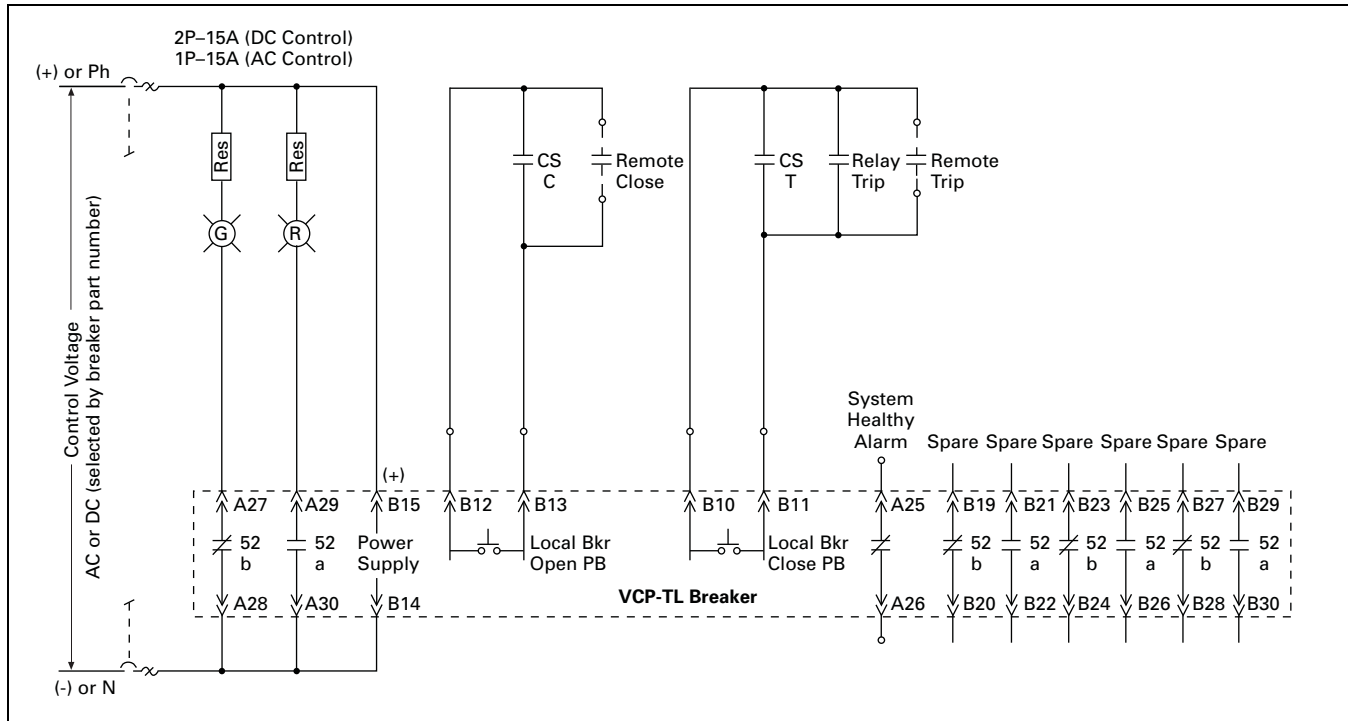

Figure 6.0-16. Type VCP-TL Circuit Breaker—Typical Control Circuit

MEF Switchgear Available Configurations with Metering Compartment

- Available MEF configurations are shown in **Figure 6.0-17**. For other configurations, contact Eaton
- If utility metering compartment is required, use MVS or VCP-W (rear-access) switchgear
- Shipping group maximum length = 104.00 inches (2642.0 mm)
- All units are 92.00 inches (2367.0 mm) tall, 61.50 inches (1562.0 mm) deep
- Main bus—1200 or 2000 A
- 2000 A breakers—1-high (one breaker/vertical section) only, except as noted in **Figure 6.0-17**
- 600 and 1200 A breakers can be stacked 2-high (breaker/breaker)
- Auxiliary shown can be either VTs (two or three) or single-phase 5 kVA CPT
- CTs or current sensors cannot be placed on main-bus side of the breaker
- CTs shown can be either one or two sets; or one set of CT and one set of current sensors
- Zero sequence CT shown can be replaced with Zero sequence current sensor
- Zero sequence CT and surge arresters shown are optional
- Maximum number of cables per phase is limited as shown in **Table 6.0-22**

Table 6.0-22. Maximum Number of Cables per Phase

Configuration		Cable Entry Direction	Number of Power Cables/Phase ①	
26.00-Inch (660.4 mm) Wide Cell	Adjacent 19.00-Inch (482.6 mm) Wide Pull Section		When Using Zero Sequence CT ②	Without Zero Sequence CT or Sensor
Breaker/blank	None	Bottom	4	4
Breaker/auxiliary	Yes	Bottom	4	4
		Top	4	4
Breaker/breaker	Yes	Top/top	1	2
		Bottom/bottom	1	2
		Top/bottom	4	4

① Multiple cables per phase are based on the use of a maximum wire size of 500 kcmil for each cable. One cable per phase is based on the use of maximum wire size of 1000 kcmil.
② When using a zero sequence sensor (for use with an integral protective relay), the number of cables is limited to one per phase with a maximum wire size of 750 kcmil.

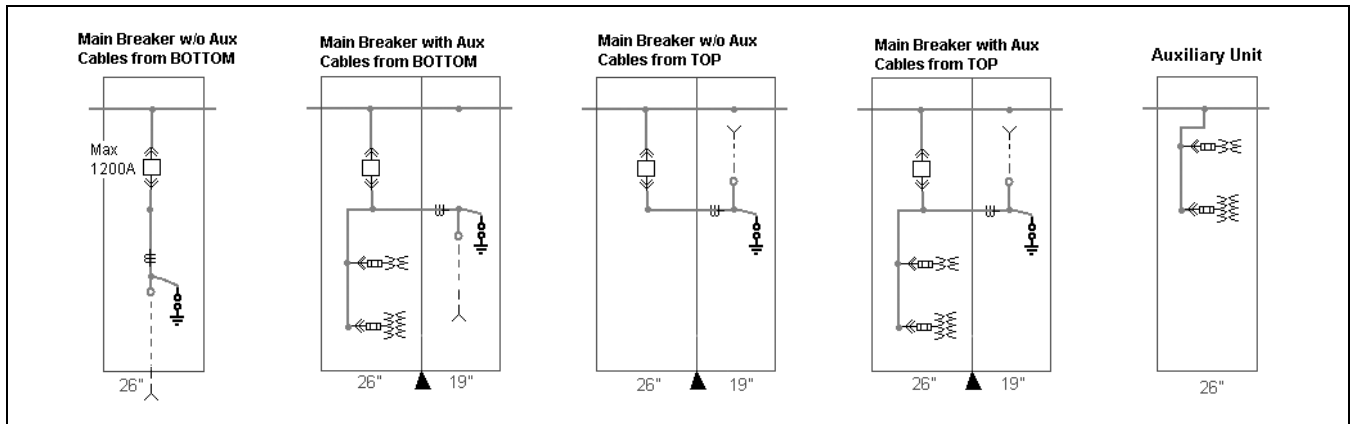

Figure 6.0-17. MEF Switchgear—Available Configurations

Note: ▲ = No shipping split here.

MEF Switchgear Available Configurations

Note: Refer to Page 6.0-31 for notes.

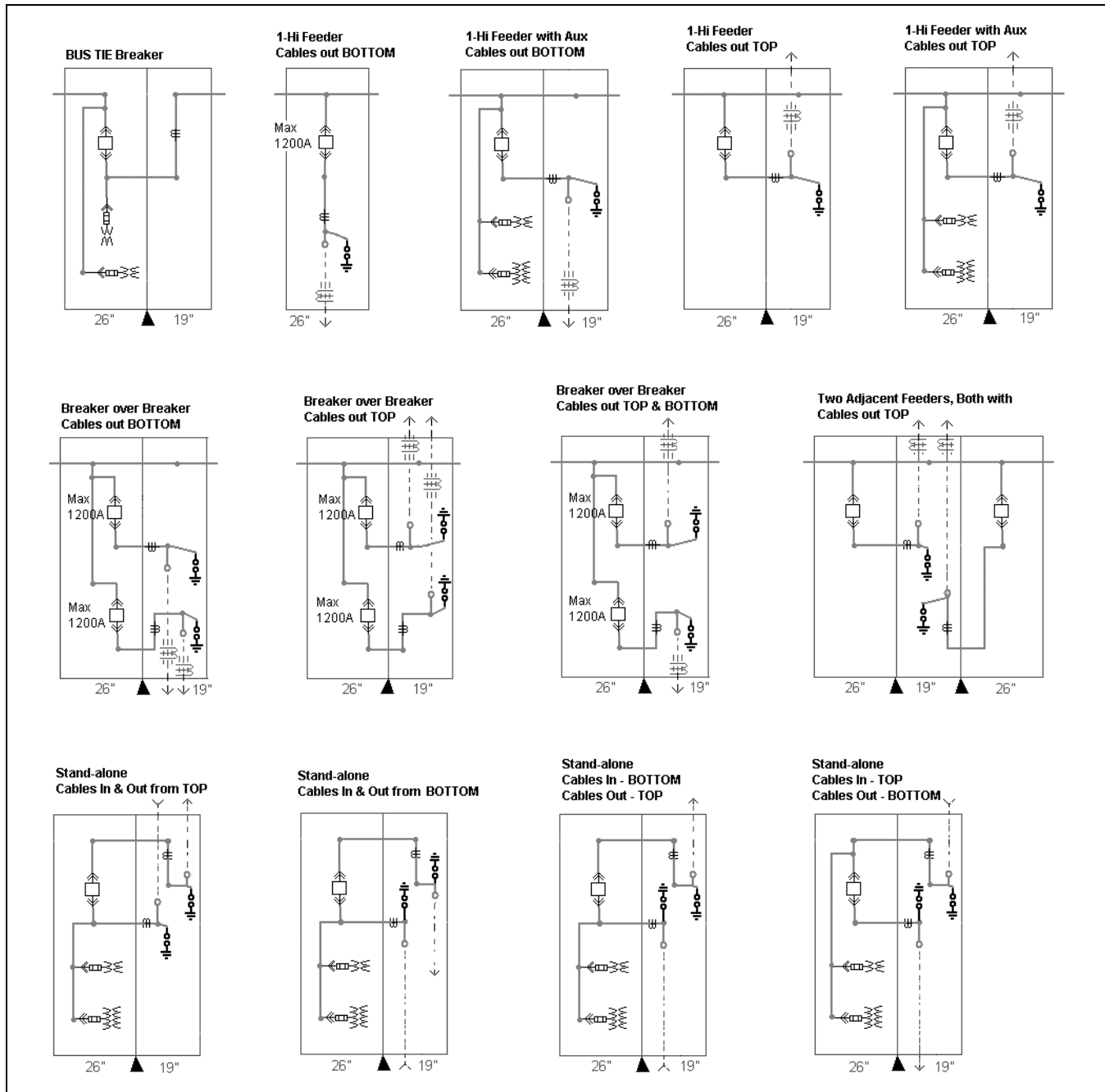

Figure 6.0-17. MEF Switchgear—Available Configurations (Continued)

Note: ▲ = No shipping split here.

MEF Switchgear Available Configurations

Note: Refer to Page 6.0-31 for notes.

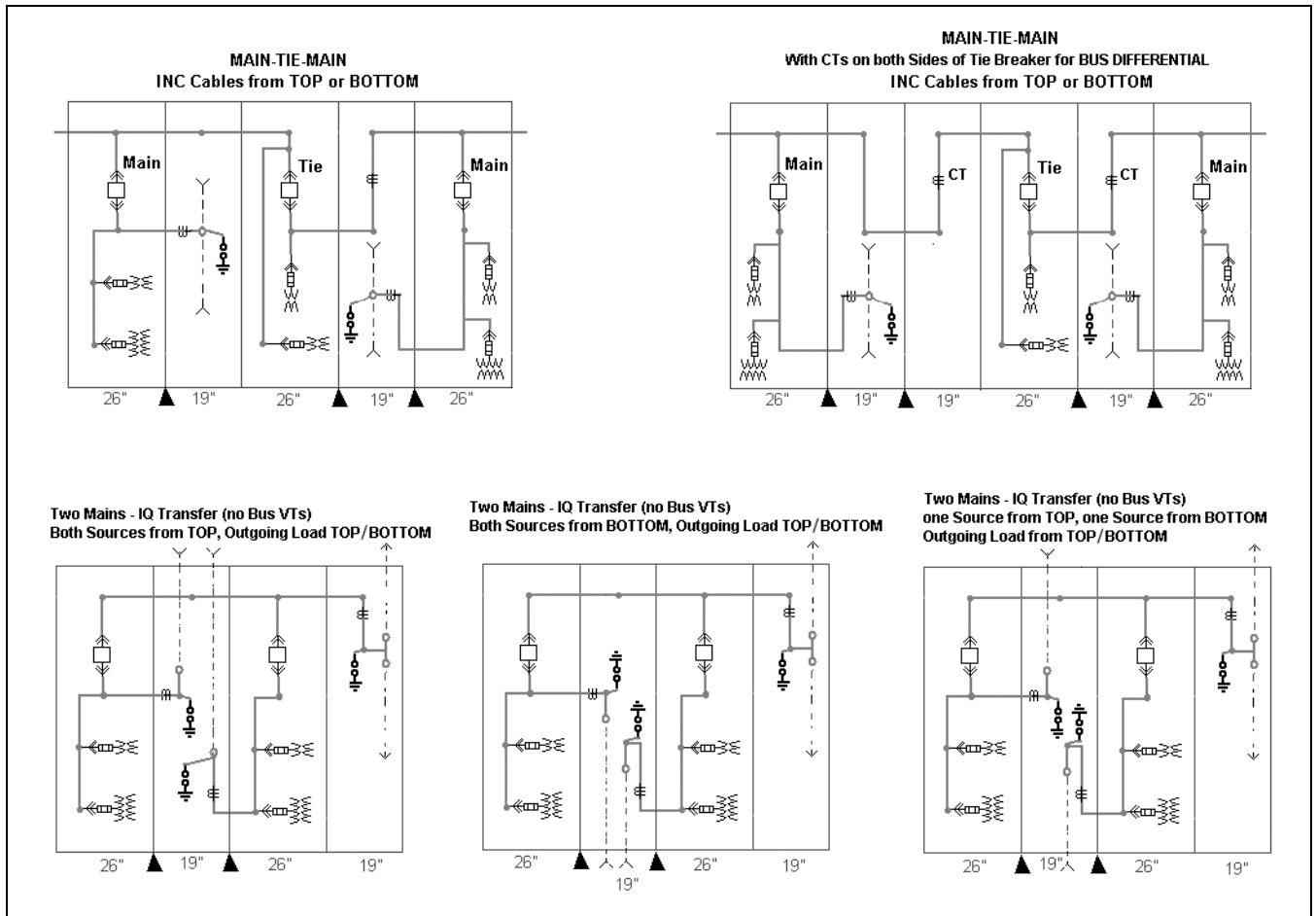

Figure 6.0-17. MEF Switchgear—Available Configurations (Continued)

Note: ▲ = No shipping split here.

MEF Switchgear Available Configurations

Note: Refer to Page 6.0-31 for notes.

6

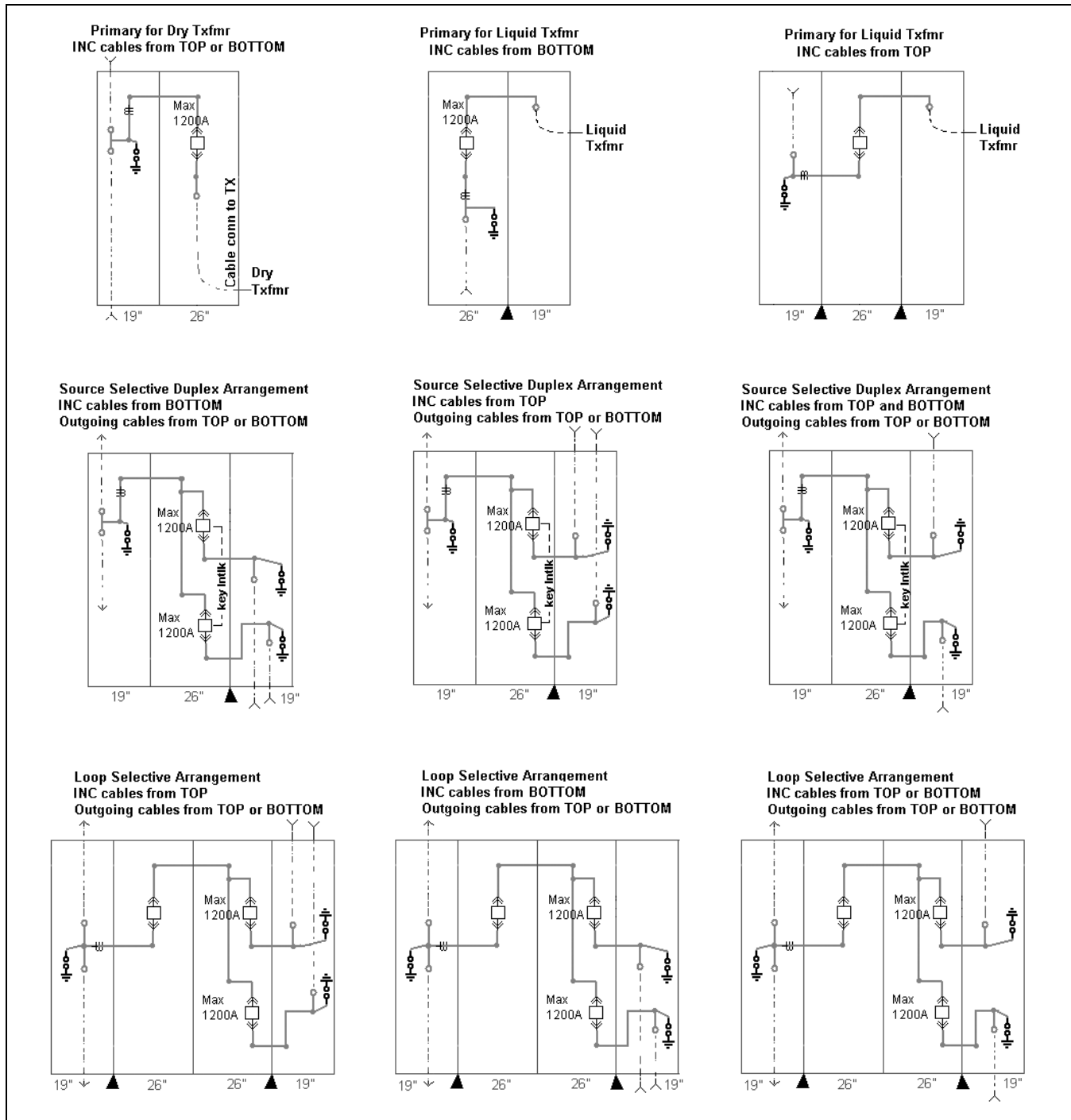
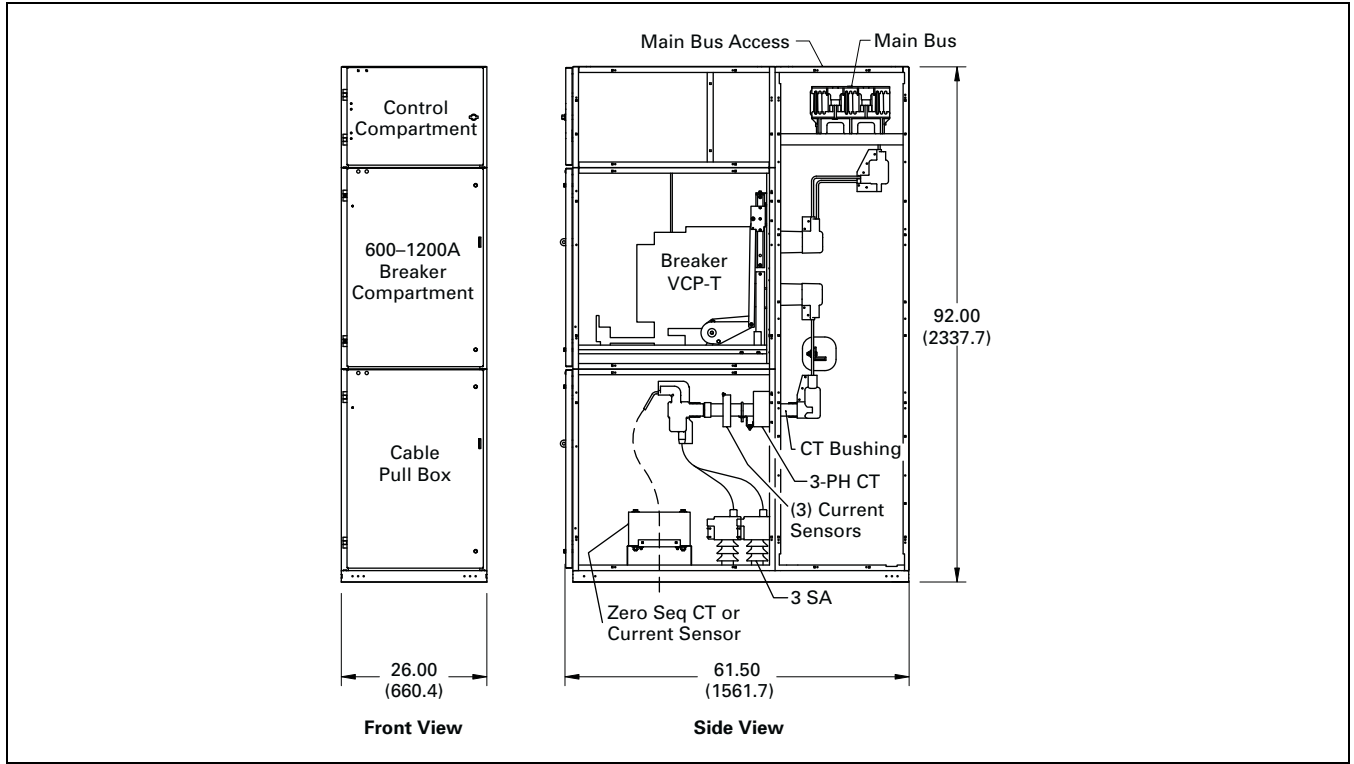

Figure 6.0-17. MEF Switchgear—Available Configurations (Continued)

Note: ▲ = No shipping split here.

Front and Sectional Views



6

Figure 6.0-18. Typical 1-High Breaker Unit, Cables Out the Bottom

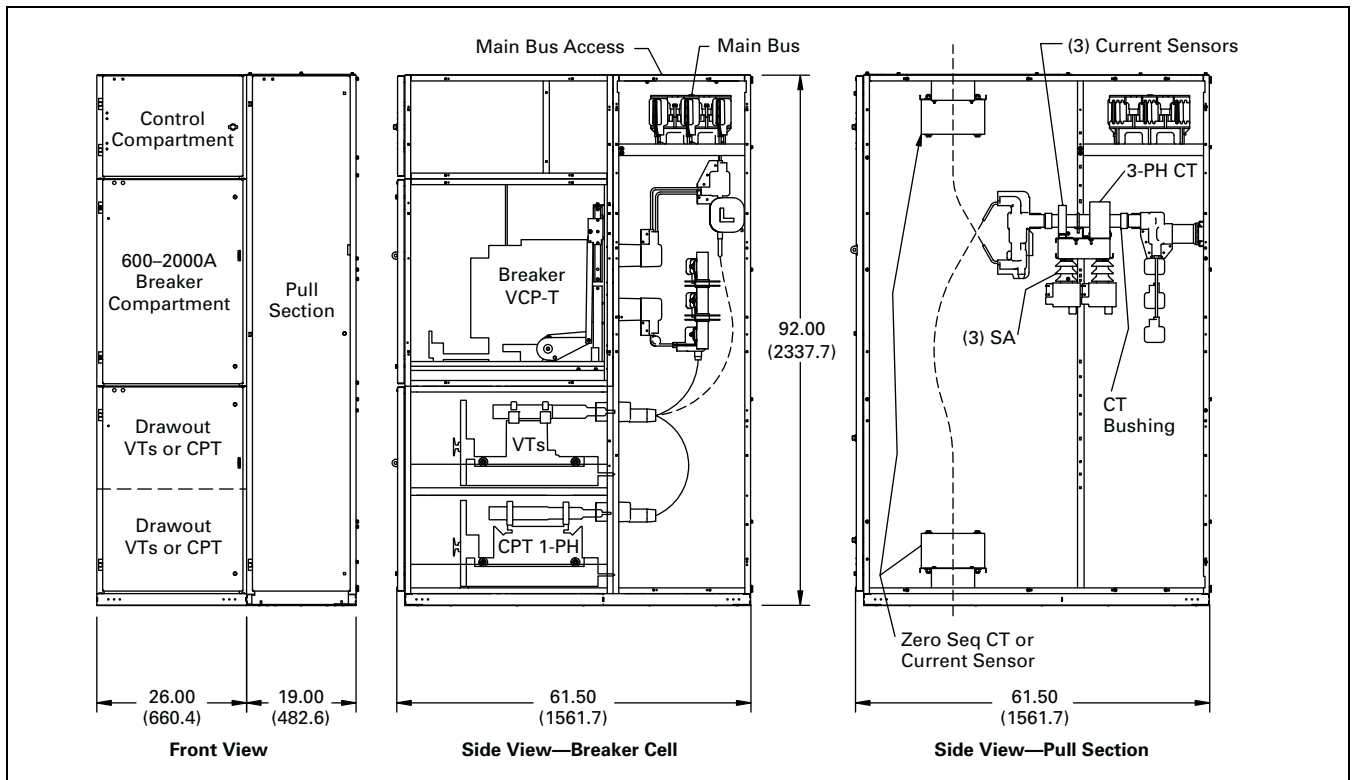

Figure 6.0-19. Typical Breaker/Auxiliary Unit and Pull Section, Cables Out Top or Bottom

Layouts and Dimensions

Front and Side Views

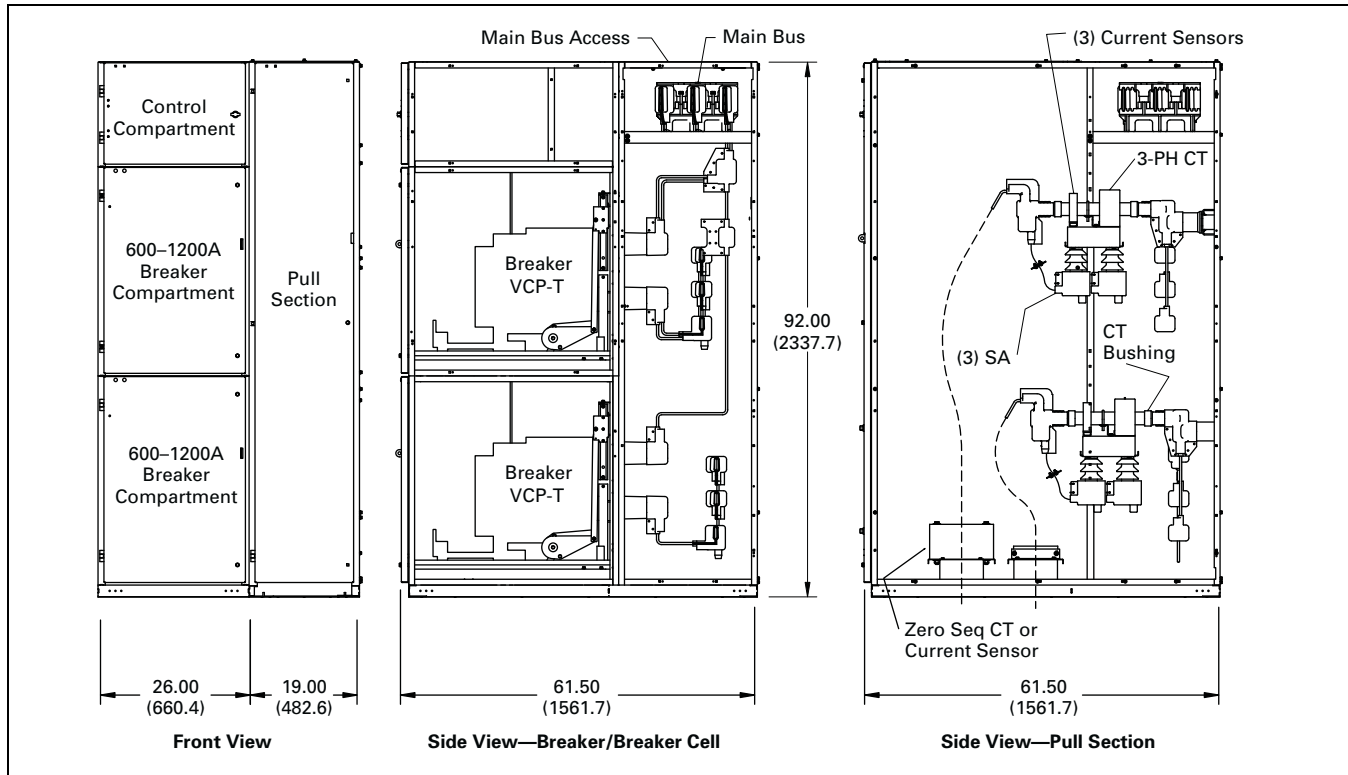

Figure 6.0-20. Typical Breaker/Breaker Unit and Pull Section, Cables Out the Bottom

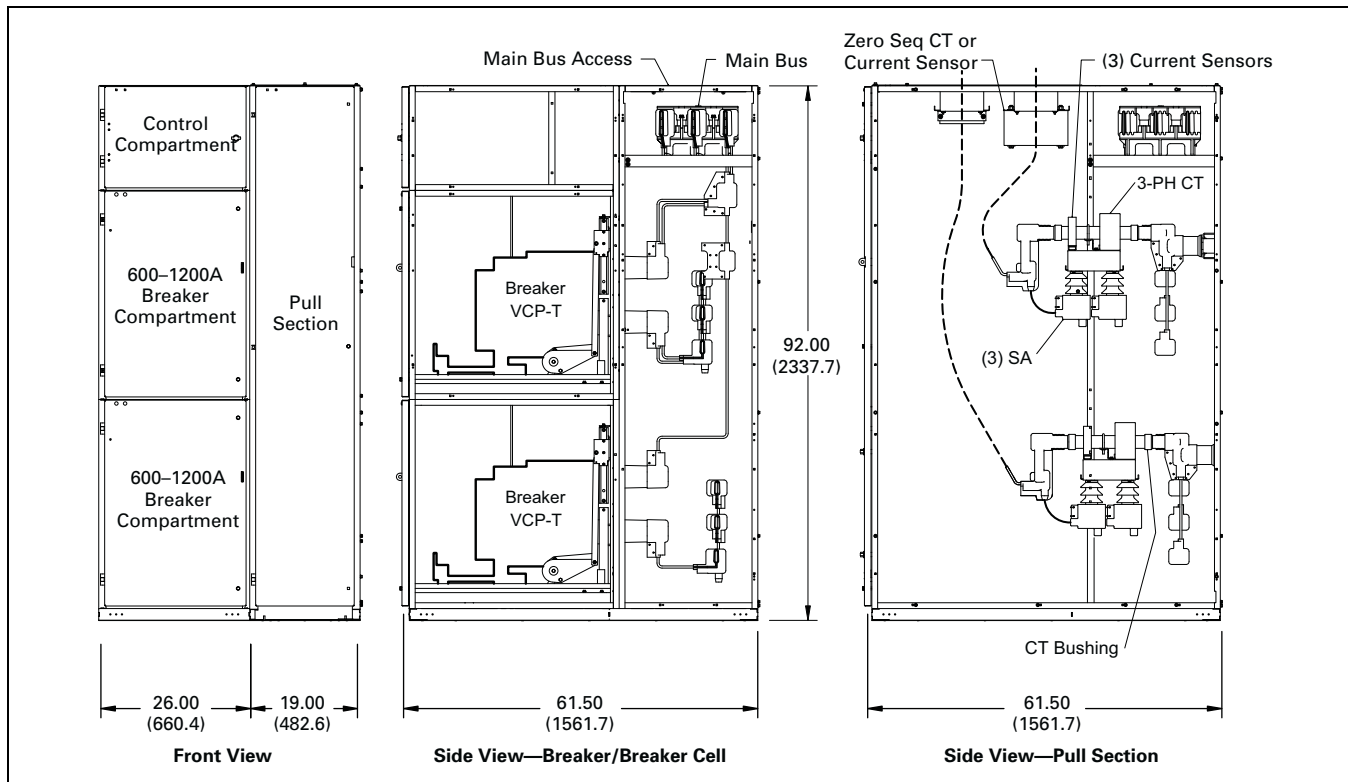
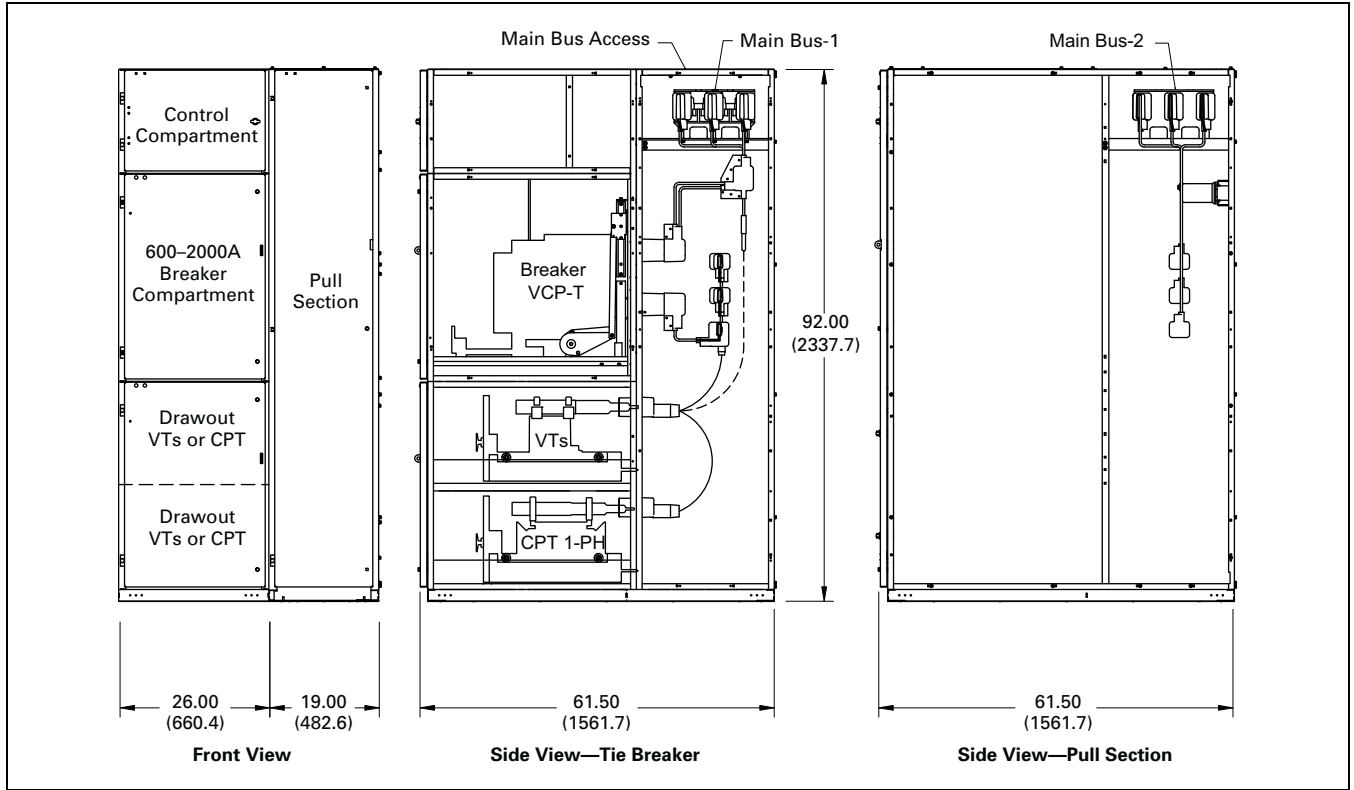

Figure 6.0-21. Typical Breaker/Breaker Unit and Pull Section, Cables Out the Top

Layouts and Dimensions

Front and Side Views



6

Figure 6.0-22. Typical Bus Tie Breaker Unit and Pull Section

MEF 19.00-Inch (482.6 mm) Wide Pull Section

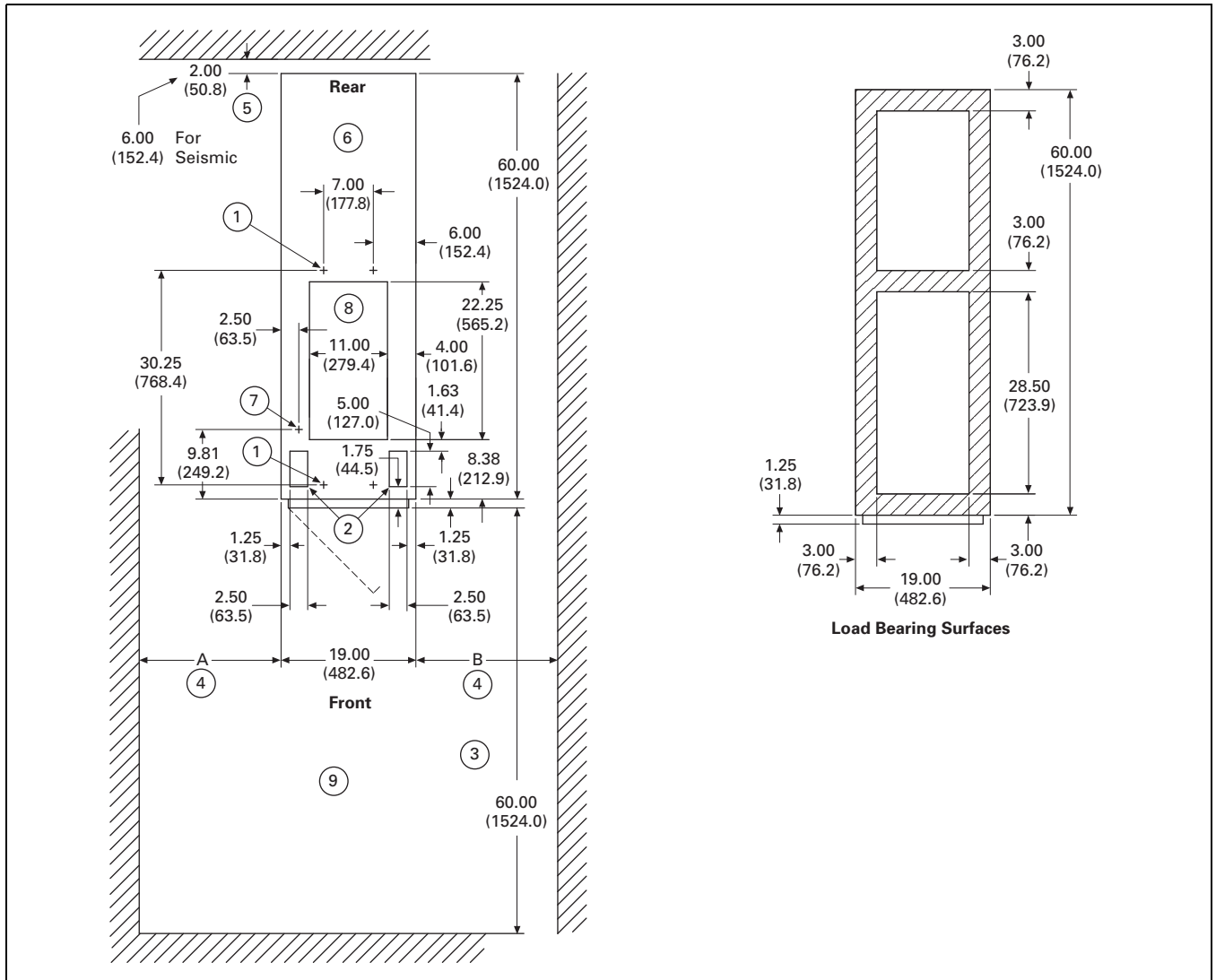

6

Figure 6.0-24. MEF 19.00-Inch (482.6 mm) Wide Pull Section Floor Plan

- ① Suggested locations for 0.50 inch bolts or welding.
- ② Secondary control wiring conduit openings (top or bottom) conduit projection must not exceed 3.00 inches (76.2 mm).
- ③ Minimum front clearance when using portable lifter. Local jurisdictions may require a larger distance.
- ④ Minimum clearance for door opening: door hinged on left A = 15, B = 6.
- ⑤ Minimum rear clearance, local jurisdictions may require a larger distance.
- ⑥ Finished foundations surface shall be level within 0.06-inch (1.5 mm) in 36.00 inches (914.4 mm) left to right, front-to-back and diagonally, as measured by a laser level.
- ⑦ Location of station grounding lug.
- ⑧ Primary cable entrance space (top or bottom entry). Primary conduit projection must not exceed 3.00 inches (76.2 mm). See shop order base plan for conduit location.
- ⑨ Minimum clearance recommended on top of the switchgear for main bus access is 24.00 inches (609.6 mm).

Layouts and Dimensions
Table 6.0-23. MEF Switchgear Units Less Circuit Breakers—Approximate Weights

Type of Structure	Structure Width Inches (mm)	Structure Weight in Lb (kg)			
		25 kA Switchgear		40 kA Switchgear	
		Main Bus Rating		Main Bus Rating	
		1200 A	2000 A	1200 A	2000 A
600–1200 A Breaker over cable entry	26.00 (660.4)	1350 (614)	1500 (682)	1560 (709)	1710 (777)
600–1200 A Breaker over 600–1200 A breaker, with an adjacent pull section	45.00 (1143.0)	2000 (909)	2250 (1023)	2670 (1214)	2920 (1327)
600–1200 A Breaker over blank, with an adjacent pull section	45.00 (1143.0)	1550 (706)	1700 (773)	1785 (811)	1935 (880)
600–1200 A Breaker over auxiliary, with an adjacent pull section	45.00 (1143.0)	2000 (909)	2150 (977)	2235 (1016)	2385 (1084)
2000 A Breaker over blank, with an adjacent pull section	45.00 (1143.0)	—	2210 (1005)	—	2210 (1005)
2000 A Breaker over auxiliary, with an adjacent pull section	45.00 (1143.0)	—	2660 (1209)	—	2660 (1209)
1200 A Stand-alone breaker, cable-in/cable-out, with an adjacent pull section	45.00 (1143.0)	2000 (909)	2150 (977)	2235 (1016)	2385 (1084)
2000 A Stand-alone breaker, cable-in/cable-out, with an adjacent pull section	45.00 (1143.0)	—	2210 (1005)	—	2210 (1005)
Auxiliary over blank or blank over auxiliary	26.00 (660.4)	1500 (682)	1600 (727)	1500 (682)	1600 (727)
Auxiliary over auxiliary	26.00 (660.4)	1900 (864)	2000 (909)	1900 (864)	2000 (909)
Blank structure (with main bus only)	26.00 (660.4)	1000 (455)	1100 (500)	1000 (455)	1100 (500)
Transition section (for close coupling to MCC, liquid or dry transformer)	19.00 (482.6)	800 (364)	900 (409)	800 (364)	900 (409)
Blank pull section (with main bus only)	19.00 (482.6)	550 (250)	650 (295)	600 (273)	700 (318)

Table 6.0-24. VCP-T/VCP-TL Circuit Breakers—Approximate Weights

Circuit Breaker Type	Continuous Current Rating Amperes	Static Weight in Lb (kg)
50 VCP-T16, 50 VCP-T20, 50 VCP-T25	1200	250 (114)
50 VCP-T32, 50 VCP-T40	2000	440 (200)
150 VCP-T16, 150 VCP-T20, 150 VCP-T25	1200	250 (114)
150 VCP-T32, 150 VCP-T40	2000	440 (200)
50 VCP-TL16, 50 VCP-TL20, 50 VCP-TL25	600	232 (105)
	1200	234 (106)
150 VCP-TL16, 150 VCP-TL20, VCP-TL25	600	232 (105)
	2200	234 (106)

Note: Breaker impact weight = 1.5 x static weight.