

Spot Network Equipment

Contents

Spot Network Equipment

Discussion

- Spot Network Decision Tree 18.0-2
- General Description 18.0-3
- Commercial Spot Network Design Considerations 18.0-5

Network Protector Equipment

- Liquid-Type Network Transformers 18.0-16
- Dry-Type Network Transformers 18.0-18
- CM52 Network Protectors 18.0-20
- Protector NPL Fuses 18.0-24
- MPCV Network Relay 18.0-25
- Communications Capabilities 18.0-27
- MPCV Network Relay Communications 18.0-28
- Communications Configurations 18.0-30
- CM52 Protector Schematic 18.0-31
- Network Disconnect Cabinet 18.0-32
- Network Transition Box to Busway 18.0-33

Rating Selection

- Spot Network Equipment Selector Guide 18.0-34
- Protector Application Information 18.0-36

Layout Dimensions

- Liquid-Type Network Unit Dimensions 18.0-37
- Dry-Type Network Unit Dimensions 18.0-38
- Dry-Type Network Unit—
Switchgear Mounted Protector Dimensions 18.0-39

Specifications

See Eaton's *Product Specification Guide*, available on CD or on the Web.

CSI Format:	1995	2010
	Section 16422	Section 26 23 16



CM52 Network Protector

Spot Network Decision Tree

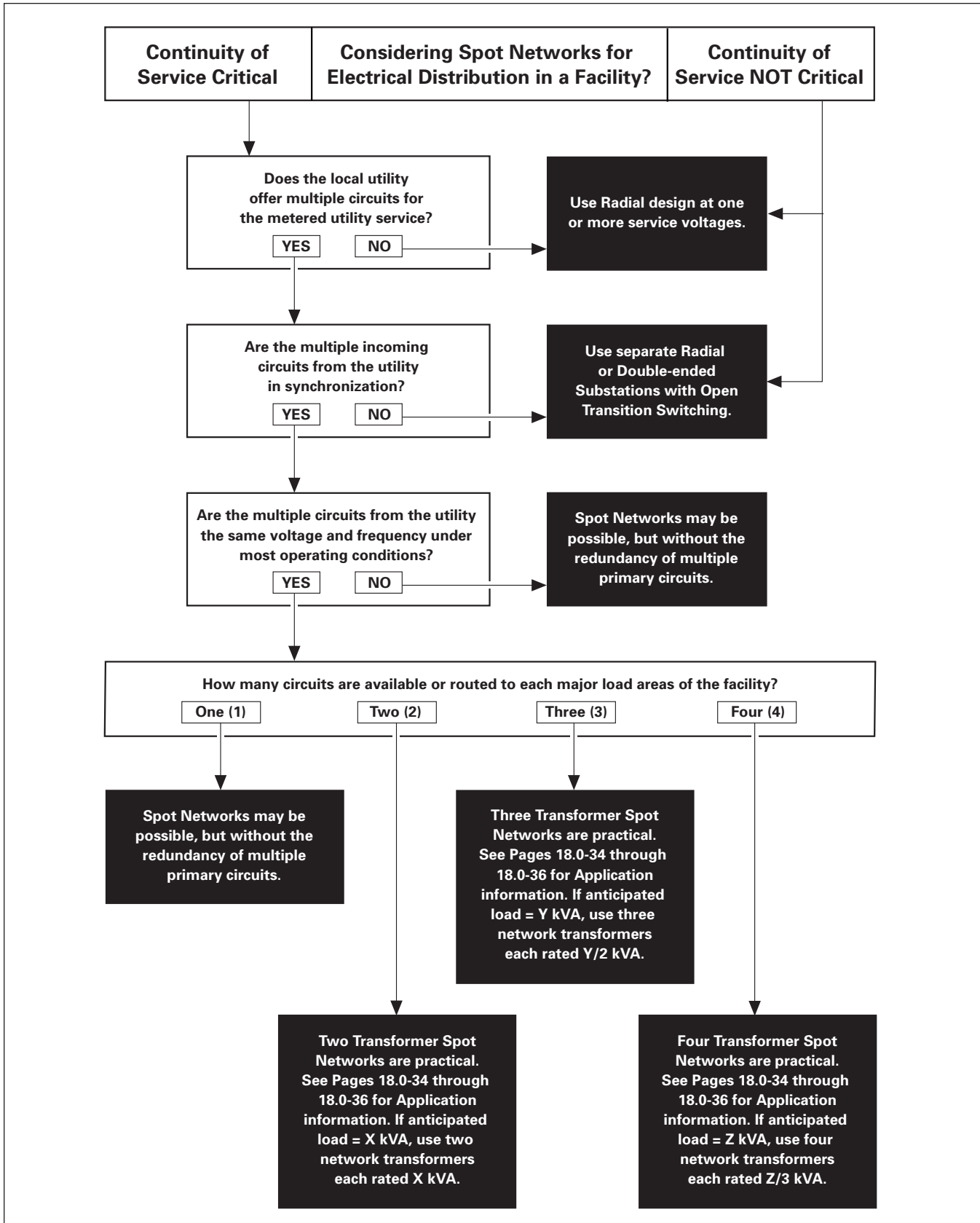

Figure 18.0-1. Spot Network Decision Tree

General Description

Description

Eaton's Spot Network Systems are designed to ensure service continuity in 208/120V and 480/277V wye connected secondary network systems. These systems, in either grid or spot network form, are commonly used in areas of high load density such as metropolitan and suburban business districts or facilities.

Suburban loads were formerly almost entirely residential and power outages caused little more than personal inconvenience. Now, the suburban load includes not only shopping plazas, industries and residences, but such vital facilities as hospitals and airports. For these and other critical loads, power interruptions can have serious consequences to public and personal safety. Spot networks provide superior reliability at these important loads.

The need to supply increasing amounts of power efficiently, without increasing equipment size, has resulted in a shift from 208V to 480V wye systems. The change to a higher utilization voltage requires a commensurate change in operating procedures because of the difference in arcing characteristics at 480V compared to 208V. For example, while an arc in a 208 volt system is normally self-extinguishing, an arc in a 480V system will usually burn until it is interrupted by an overcurrent device or until it totally consumes the arcing material.

Secondary network systems using Eaton Network Protectors are among the most dependable in use today. In the event of a fault on a primary system cable or transformer, the protector opens due to reverse power flow, thus isolating the fault from the network bus and avoiding load power disturbances. Loss of the primary feeder will not result in service outage at the load on the secondary network. The other primary feeders will continue carrying the load until the faulted cable is repaired and returned to service.

The network protector basically consists of a special air power breaker, a breaker operating mechanism, network relay(s) and control equipment. Units are available in both weather-proof and submersible enclosures for either separate or transformer throat mounting. Switchgear mounting is also possible.

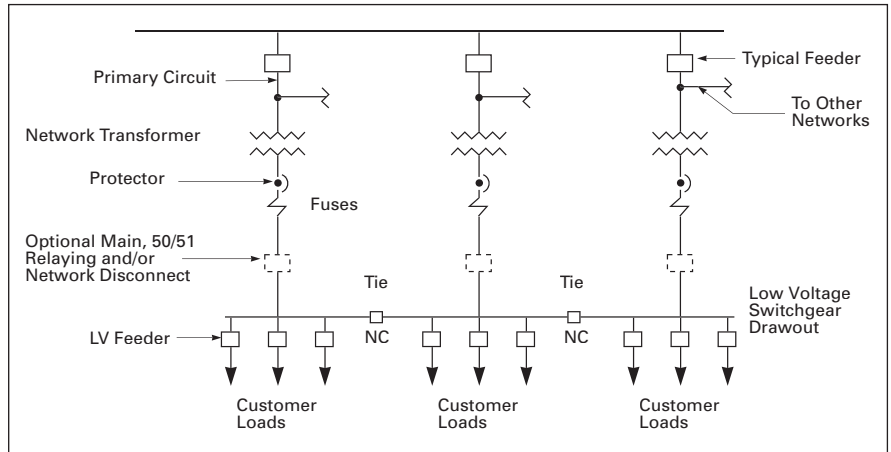

Figure 18.0-2. Typical Configuration for Three Transformer Spot Network

Better Continuity of Service

The largest user of network systems in the United States is Consolidated Edison of New York. Historical data developed by this utility illustrates that outages are very rare (approximately zero) on grid systems and that spot network systems are five times more reliable than secondary selective double-ended substation services.

Improved Regulation—
Less Voltage Sagging

Each load is supplied from at least two directions. Services supplied from a transformer location have a minimum of two paths of supply on utility grids and spot networks, and can be designed to have more. Abrupt changes in loads, such as motor starting, cause much less voltage disturbance due to the multiple paths for load current compared to simple radial services. The voltage dip resulting from a given starting current may be 70% less in a network system than in a radial system.

Less Transformer
Capacity Required

In normal operation, the loads along the network service are divided among the various network transformers in such a way that the best possible voltage conditions and lowest losses are realized. Since all the services are tied together, many more loads are supplied from the same secondary network source than in a simple radial system. The peak loads on the transformers are correspondingly lower in the network system compared

to a radial system supplying the same loads, because of the diversity in the demand among the larger number of circuits. Therefore, less transformer capacity may be required in a network system than in a radial system in the same area, particularly if three or more primary feeders supply the network system.

System Operation

A short circuit on any one primary feeder will cause all the network protectors on that feeder to open on reverse energy, provided the total power on the three-phase feeder is in the reverse direction. When the feeder cable is repaired properly, the network protectors on that feeder will automatically reclose when the feeder circuit breaker at the upstream switchgear is closed, if correct voltage conditions exist at the network transformer.

If the phases are reversed during the cable repairs, the protectors will not reclose automatically as long as the network remains energized. Likewise, if a voltage less than network voltage is restored to the feeder, the network protector on that feeder will not reclose automatically. The unit could be closed manually if the network relay trip contact is not closed.

If a feeder from a networkable source is to be connected to an energized network, the incoming voltage must be slightly higher than the network voltage and in proper phase relation with it. If a feeder is being connected to a dead network, it is sufficient to have the incoming voltage high enough to operate the closing mechanism.

General Description

Maintenance of primary feeder circuits can be accomplished by opening upstream switchgear primary devices one at a time, thereby opening every protector connected to a given primary due to reverse magnetizing currents flowing through each protector served. By opening the primary circuits one at a time, the network loads are not disturbed. Also, at times of light load, the system can be economically loaded by disconnecting some of the primary circuits and operating the transformers at more efficient levels. Although the protectors are capable of opening under reverse magnetizing currents, the opening may be delayed depending upon the time delay setting of the network relay.

When the load increases on the network, other primaries can be brought into service by closing the feeder breakers. The associated protectors on the reactivated feeders will reclose serving the network if the transformer voltage is higher than the network voltage by a certain minimum amount and in the proper phase relation.

The network protector fuses provide backup protection for clearing faults on the primary feeder in the unlikely event the protector fails to operate. These melting alloy or partial range current limiting fuses are located on the load side of the protector, and when removed, serve to isolate the protector from the network.

Numerous protector models are available from Eaton and the best product for the application is a function of the type of system being designed: utility grid (see **Figure 18.0-3**) or spot network (see **Figure 18.0-2**) usually use the CM52 type of protector, which has important safety features not found on earlier Eaton or competitor models.

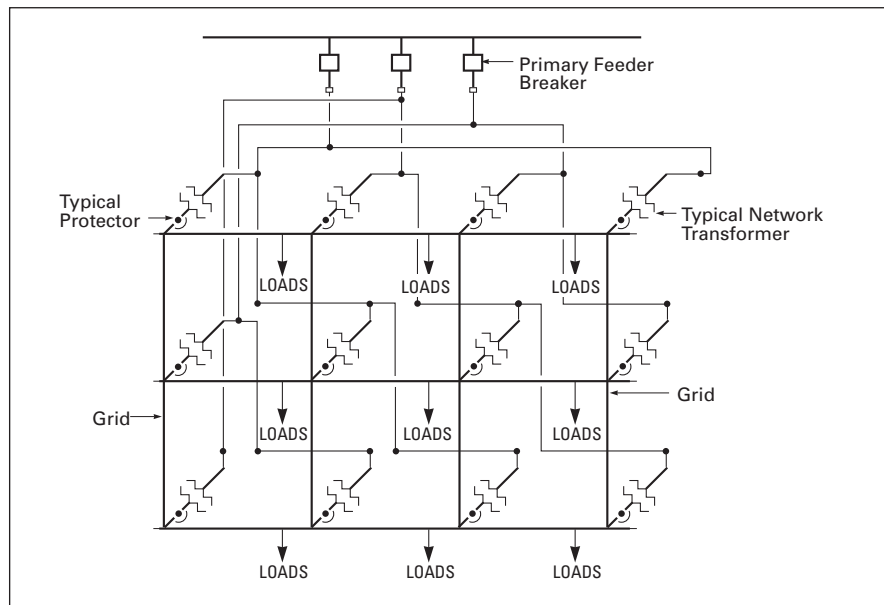

Figure 18.0-3. Typical Configuration for Utility Grid Network

CM52 Protector Advantages



CM52 Protector

Exclusive Drawout Design: With positive safety interlocks, provides maximum protection against contact with energized components while disconnecting the unit for test or maintenance; ensures maximum safety for operating personnel. All main current carrying and mechanical operating components are located behind a deadfront panel which minimizes the possibility of tools or hands being inserted into an energized protector. The drawout unit is operated by a hand-cranked levering system, which cannot be engaged unless the circuit breaker is open and cannot be disengaged unless the drawout unit is either fully disconnected or fully connected.

Modular Construction: Simplifies field maintenance and/or replacement of components. Protectors can be quickly

put back into service reducing maintenance time.

Spring Close Operating Mechanism: Avoids partial closures. The CM52 spring close mechanisms will not permit closing motion of the contacts until the closing springs are fully charged. Also provides close and latch ratings on protectors.

Externally Mounted Silver-Sand Fuses: Operate with no contamination of the protector, and will positively interrupt fault current to disconnect the protector from the network bus in abnormal fault situations.

Low Energy, Trip Actuator: Provides reliable tripping effort, even when system voltage is not available, up to four operations via remote tripping before recharging is needed.

Close and Latch Ratings: Ratings comparable to air power breakers are readily available since the mechanism is spring charged, unlike motor operated protectors which have no close and latch ratings.

Increased Dielectric Strength: CM52 units have passed a more stringent dielectric test voltage of 5000 Vac compared to the lower value of 2200V required by ANSI standards.

Stored Energy Option: The CM52 can be provided wired for stored energy. This option charges the closing springs after a closure, resulting in a 5-cycle close after a trip event. This is the preferred configuration for 2-unit spot networks.

Commercial Spot Network Design Considerations

This section deals with the various components which make up the commercial spot network, either as a double-ended substation or multiple transformer substation. The intent of the discussion is to give some basic guidelines for the selection of Eaton transformers and network protectors. The major components that will be discussed are:

1. Primary switches
2. Network transformer types
3. Network protectors
4. Spot network disconnects
5. Low voltage drawout switchgear configurations
6. Typical spot network layouts
7. Use of current limiting fuses
8. Network device coordination

1. Medium Voltage Primary Switches

The incoming medium voltage feeder may range from 4160V to 34.5 kV. Any feeder which has a voltage higher than 34.5 kV should not be considered for spot network service because the cable charging capacitance begins to affect the operation of the network relay response. The primary feeder enters into a switch compartment, which can be liquid or air type. The liquid type transformers usually use a special three-position, liquid-filled, non-loadbreak primary switch, which has a special third position for grounding the incoming feeder cable during maintenance work on a primary circuit. Dry-type transformers usually use a two-position air switch, which omits the third position. Grounding the circuit becomes a manual procedure, if needed, on dry-type transformers.

The three positions of the liquid type non-loadbreak switch on liquid network transformers are:

1. Close
2. Open
3. Ground

These liquid switch designs use electrical interlocks that prevent the unintentional movement of the switch, with either the network protector in the "Closed" position or the medium voltage feeder being energized.

Figure 18.0-4 shows the typical

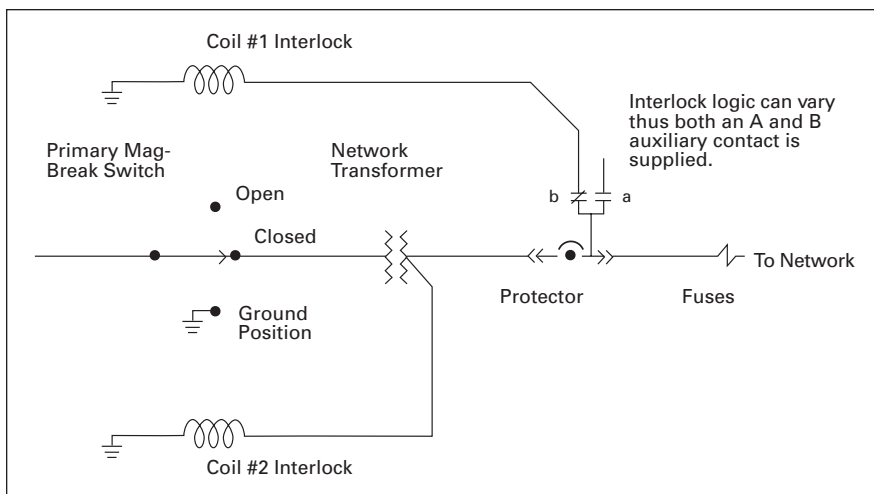

Figure 18.0-4. Three-Position Primary Switch Interlock for Liquid Network Transformers

electrical connections for the interlocking between the primary switch, transformer and network protector.

Coil #1 and #2 are electrical interlocks which prevent unsafe operation of the primary mag-break switch. Coil #1 ensures that the protector must be used to break load current before operating the switch from closed to open. Coil #2 ensures that the primary cable must be deenergized before operating the switch from closed to ground. These interlocks are not necessary on a two-position air switch if it has loadbreak ratings.

Due to their common use, liquid type network transformers are manufactured with the three-position mag-break only switch integral to the transformer. Dry-type transformers use the commonly available two-position air switch with special flicker blades which give the air switch a loadbreak rating. The capability of interrupting load currents can save time by not having to deenergize the feeder. The choice of switch type is thus dictated by the type of transformer selected for the spot network system.

Another consideration is the necessity to provide primary overcurrent protection for each transformer, such as in the form of power fuses. Upstream breakers usually serve two, three or four transformers on their circuit and thus have the protective relays set at higher levels dictated by the entire circuit load, which sacrifices individual transformer protection. See **Figure 18.0-13** later in this section for a specific example of this type of situation. When dry-type units are used, one solution is to add power fuses to the loadbreak switches. However, this option is not easy when liquid types are used unless air

switches are added ahead of the integral type liquid switches. Eaton recommends that no more than two transformers be served by a single upstream breaker and relay, unless separate fused air switches are located ahead of the transformers.

If fuses are used anywhere in the primary circuit, the network protector relays must be capable of tripping under WATT-VAR conditions. New digital type network relays have the ability to configure their tripping characteristics from WATT to WATT-VAR in the field. Older type protectors having electro-mechanical relays should be updated by retrofitting with the newer relays. If fuses are not present, the standard WATT trip characteristic, which is standard in the industry, is appropriate.

Each type of primary switch uses unique terminations of the primary cable. Liquid switches use a terminal chamber which is filled in the field with a suitable compound to improve the insulation strength of the cables. Air switches use mechanical or compression terminations with stress cones.

Air switches require more floor space than the integral liquid type of switch, especially since the depth of the air switch is made to match the depth of the transformer. Transition sections add to required floor space if hard bus connections, not cable, are required. Whereas the three-position liquid switch dimensions are no greater than 20.00 inches (508.0 mm) deep off the end of the transformer and 30.00 inches (762.0 mm) in width centered at the end of the unit.

Commercial Spot Network Design Considerations

It is possible to use both types of switches for liquid installations. Groups of air switches can be mounted along a wall to receive and distribute primary circuit power to each transformer. Individual power fuses can be mounted within the air switches. Dry-well mounting of current limiting fuses in air canisters accessible from the top or side walls of the transformer is not recommended. The available space will dictate much of the design if sufficient space is not allocated for electrical system equipment.

Primary switches accommodate the three-phase conductors and never use a neutral conductor. Most spot networks use delta wound transformers, so there is no need to deliver the neutral through the primary switch. Any type cable can be used, however the more modern types are easier to handle than paper lead insulated types which require potheads for terminations within the primary switch.

2. Network Transformer Characteristics

After the primary switch, the power is delivered to the primary windings of a network type transformer. The design may be liquid- or dry-type, with liquid types being more popular from a historical perspective, due to their application in utility systems. However, dry-type designs are now available meeting the ANSI network standards. Most applications within commercial buildings desire dry-type designs due to the desire to avoid the fire hazard associated with liquid dielectrics. It is important to use proper dry-type ratings which mimic the overload characteristics of liquid units, therefore dry types should be rated for 80°C rise and use Class H-20°C total temperature insulation materials in VPI designs or 185°C in cast coil designs. Fans are normally employed to aid the air cooling during periods of overloading, and which occur during a single primary outage.

Secondary voltages are always 480V wye or 208V wye. Also, 216V wye is a common rating. Primaries are always delta, such as 4160V, 13.2 kV, 13.8 kV, etc.

Transformer impedances should fall within the standard ranges indicated in **Table 18.0-1**, or else the usual protector interrupting ratings may become inadequate. If impedances drop below these values, the maximum through-fault may exceed the interrupting rating of the protector.

Also, the impedance values among transformers in a spot network should be as close in value to each other that manufacturing tolerances will allow; this helps reduce circulating currents between transformers.

Table 18.0-1. Transformer Impedance

kVA Size	Recommended Z
300-1000	5% or greater
1500-3000	7% or greater

Notice that 3000 kVA is typically the largest transformer that can be used for network services, although Eaton can go higher.

As an example, let's assume a two-unit spot network using dry-type transformers having 80°C temperature ratings. In this example we calculate that the building load will not exceed 1495 kVA. Since we are designing the service as a double-ended network substation, either transformer must be capable of carrying the full building load of 1800A.

One choice is to select a 1500 kVA transformer size which has a full load rating of 1805 amperes. However, in specifying transformers for network services, the units can be undersized, realizing that under most conditions both units are available to supply power to the network. When only one is handling the entire load, it should be considered an abnormal event that should not continue indefinitely.

For our load of 1495 kVA, a 1000 kVA transformer will supply 1888 amperes at 157% of nameplate rating, therefore we would select a 80°C rise 1000 kVA dry-type unit operated at 115°C with fans (157% overload capability) and a protector with a continuous rating of 1875A.

In all spot network designs, the equipment must be sized to handle the load even though one primary, and thus one transformer, is out of service (known as a single contingency condition) for some period of time. The basic design constraint is that the load not exceed the maximum thermal rating of the remaining unit(s) during the time of the single contingency. Protector ratings recommended by vendors, as well as protector circuitry, anticipate the loads and are sized to handle the higher currents, so the limiting factor is the transformer.

One advantage of liquid designs is their large thermal mass which enables them to handle higher currents for a longer period of time without the need for an

FA fan rating when compared to conventional dry-type designs. When both transformers are available, the 1000 kVA units in our example will only be loaded to 75% of their AA base rating.

The transformer winding configuration will depend upon the primary service available and the type of service needed by utilization equipment comprising the loads. For the most part, transformers are DELTA-WYE, which permits the lowest ground relay pickup value for the primary feeder breaker. This type of winding configuration also eliminates any zero sequence current in the primary feeder for load unbalances in the secondary. At higher primary voltages, 27 kV through 34.5 kV, some use has been made of GROUNDED WYE-GROUNDED WYE windings. The advantage gained is the reduction of overvoltages which can result if one leg of the unit is de-energized. The disadvantage is that the primary breaker ground relay must be set much higher because load unbalances and ground faults in the secondary are reflected by zero sequence currents in the primary circuit. See **Pages 18.0-16 and 18.0-18** for network transformer features.

3. Network Protector

The network protector can be provided in a weather-proof NEMA® 4 housing, submersible or suitable for mounting within a low voltage switchgear assembly. Both the transformer side (line) and network (load) connections of the protector are bus bar which can accommodate transformer flange connections and loadside connections to cable, busway or switchgear buswork.

Network protectors are special self-contained air power breaker units having a full complement of current, potential and control transformers, as well as relay functions to protect the integrity of the low voltage network bus. Normally, protectors do not have any overcurrent protection in the forward direction; if necessary, the 50/51 function can be achieved through the use of remote mounted protective devices.

Figure 18.0-5 illustrates a simplified diagram of the various components of the network protector.

Note: The symbol for a protector is the air breaker symbol with a dot in the middle.

Protectors have either rollout or drawout mechanisms for easy maintenance. Protectors having the drawout mechanisms, such as the CM52 type, are comparable to air power breakers in terms of maintenance and stored energy functions. The older rollout units use manually disconnected fuses and links which must be removed from the energized network bus prior to rolling the unit out of the cubicle for inspection, testing and maintenance. Details on protectors are reviewed later in this section and the recommended spot network equipment ratings for two, three and four unit configurations are shown in **Tables 18.0-9** through **18.0-12** that appear on **Pages 18.0-34** and **18.0-35** in this product section.

The protector load side contains a network fuse, usually a partial range current limiting type. The fuses are present as back-up protection if the protector fails to open properly. These fuses are separately removable, but do not drawout with the protector mechanism. Commonly, the fuses are located at the top of each protector.

The fact that the fuses are located on the network side means that fuse maintenance requires operators to come into contact with live parts and conductors which can deliver high fault currents. A method of easily disconnecting the secondary of the protector from the network bus, similar to the configuration of the primary, is needed to isolate the fuse and protector, thus the need for a network disconnect.

4. Spot Network Disconnects

The multiple sources of power to the network bus can create a safety concern on the load side of each protector. Obviously, each protector loadside is energized from the network so long as at least one transformer remains connected. The use of a network disconnect can provide a degree of operator safety by requiring that the disconnect be used to disconnect the protector loadside from the network before allowing access to network fuses or protector mechanism. Such a disconnect reduces the likelihood of contacting live bus and forces operators to follow a safe procedure prior to any protector maintenance. Accidents involving protectors can be traced to the absence of such devices in customer's facilities and distribution system designs. Eaton encourages the use of network disconnect devices, especially in facilities not having

dedicated maintenance staff. Many forms of disconnect devices are available; the specific choice depends upon several related factors such as protector mounting, use of main breakers, protector type, etc. Three key choices for network disconnect devices are outlined below.

Types of Network Disconnects

Principally, the two types are main air power circuit breakers within switchgear assemblies and non-load-break hookstick operated switches mounted above the protectors in a NEMA 1 cabinet.

Regardless of the type used, each disconnect is interlocked with the protector to ensure that the loadbreak protector is used to break and make the load currents. The protector mechanism is rated for at least 10,000 operations before maintenance and is the best device to interrupt normal load currents. Protectors include an operations counter to keep track of the number of operations. The interlocks may be keyed type or electrical control wiring. Refer to **Figure 18.0-6** for a typical one-line.

Main Breakers

Main air power breakers are the safest option to use as a network disconnect, however their interrupting rating guarantees proper operation under all conditions including fault currents. Switchgear mounting of the main breakers means that the disconnect device is the same type of device as all other overcurrent devices mounted in the assembly, thereby requiring common maintenance and operation procedures. The mains can be key interlocked with their respective protectors to ensure that the protectors are opened first, then the mains are opened and racked to a disconnect position prior to maintenance of the protector or circuit devices.

Main breakers include overcurrent trip units to provide individual overload protection for each protector and conductors. This protection is not a normal function of the network relays and augments protection generally so long as the trip unit settings are properly coordinated with the tie and feeder devices. The trip unit protection does not protect the incoming cable against fault currents such as ground faults or short circuit currents; the sensors are not located at the lineside of the protector circuit, rather they are at the switchgear (load) side thus giving only overload protection.

The key interlocking between main air power breakers and network protectors may be eliminated since the main is a true interrupting device usually rated at or above 65,000A interrupting at 480V. When mains are used as loadbreak devices on network services, the opening of a main may result in the opening of the respective protector, however maintenance procedures should always verify protector operation.

Non-Loadbreak Disconnect

The network disconnect device for mounting above the protector is the non-loadbreak bolted pressure switch. The device is hookstick operated from the floor and provides a reliable means of visibly disconnecting the protector circuit from the loadside of the protector. The switch is NEMA 1 cabinet mounted with double doors and electrical interlocks to assure that the protector is used to break the load current. The door interlocks have a defeatable procedure if qualified personnel need to gain access under load flow conditions. Key interlocking with the protector is not necessary.

Commercial Spot Network Design Considerations

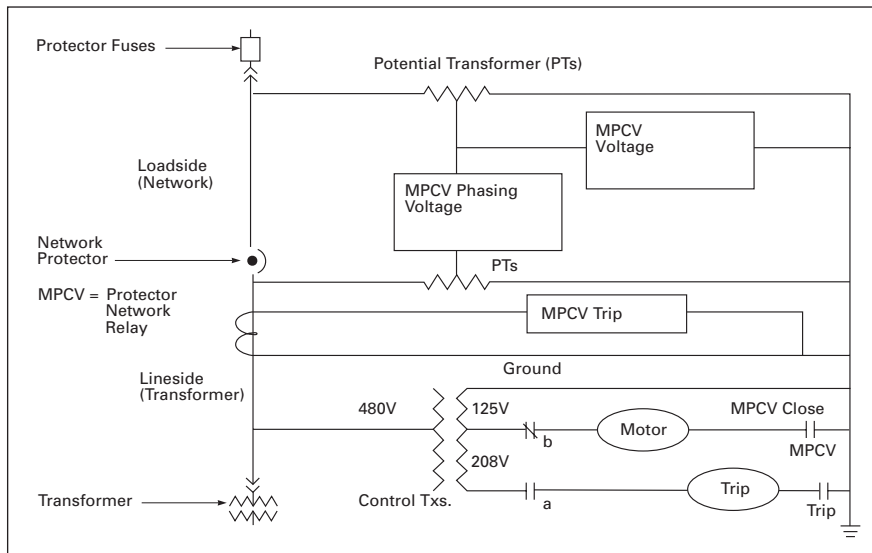

Figure 18.0-5. Typical Network Protector Schematic

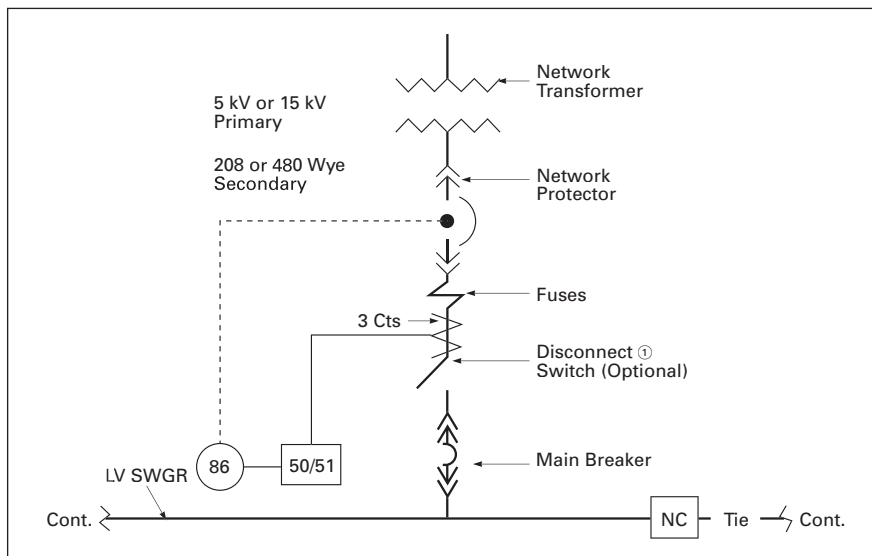

Figure 18.0-6. Partial Spot Network One-Line Diagram

① Recommended when no separate main breaker is used.

This product has become a standard for Eaton and is manufactured in the same plant as the protector for improved assembly and product coordination. Recent designs move the NPL fuses on the protector into the disconnect cabinet to ensure that fuses have controlled access. Space exists within the cabinet to mount separate current transformers to provide inputs for separate instantaneous and time delay overcurrent relays which protect the protector circuitry from point of supply to the switchgear buswork. The General Services Administration uses this type of product on hundreds of network units throughout the National Capital Region and in other areas of the country where networks are used.

The non-loadbreak design has been chosen over the loadbreak for several reasons. First, the loadbreak mechanisms need regular maintenance and should not be allowed to sit in a closed position for years, then be called upon to operate without failure. This type of duty is exactly what is required of a network disconnect. Additionally, the operating mechanism of a loadbreak design requires a lot of force, more than an operator can safely deliver from a ladder or step. Hookstick operation from the floor is a safer procedure. Refer to **Figure 18.0-7** for typical section view of network units using a network disconnect atop the protector.

Network transformer neutrals are brought to the loadside area of the disconnect for transitioning to the protector circuit neutral for delivery into the switchgear. The loadside of the disconnect can accommodate outgoing busway or cables as needed. See **Page 18.0-32** for network disconnect features.

50/51 Relaying for Protectors

Users who specify the non-loadbreak disconnect can easily add the current transformers for relaying at the load side of the protector circuits and provide superior fault and overload protection for the incoming conductors between the protector and the switchgear buswork. The relays are usually mounted within the switchgear and use a lockout feature to trip and lockout the protector. Modern microprocessor relays such as the Eaton Digitrip® 3000 can also be used for the 50/51 protection to save costs and mounting space.

The use of forward relaying on the protector circuit needs to be coordinated with the tie breakers to ensure that the protector auxiliary 50/51 protective settings are not faster than the tie settings. Coordination is achieved when the ties are faster acting than the 50/51 protector forward overcurrent relays, and they usually trip open first due to the presence of multiple transformer faults passing through the ties. See **Figures 18.0-14** and **18.0-15** for more details. Also refer to tables on **Pages 18.0-34** and **18.0-35** for details on the recommended tie device ratings and settings.

The use of forward relaying current transformers is recommended even when the non-loadbreak disconnect is not used, such as occurs when only transition boxes are used at the top of the protectors.

System Neutral Grounding

Regardless of the device selected as the network disconnect, the XO transformer neutrals are not grounded at the transformers. Rather they are brought into the switchgear and grounded at one and only one location. This configuration allows the use of the ground return method of ground fault protection whose zone of protection extends from the secondary transformer windings to the outgoing air power breakers in the switchgear. Other ground fault detection methods are possible, but are considerably more complicated to wire and maintain and are without significant advantage or greater reliability.

5. Low Voltage Drawout Switchgear Configurations

The most reliable and safe network bus equipment is in the form of low voltage drawout switchgear built per ANSI C37 standards. Unlike the UL® 891 switchboard assemblies, low voltage switchgear uses true 200,000A braced buswork, 30 cycle short time ratings, drawout stored energy air power circuit breakers rated for 100% application, for easier maintenance—all of which provides superior performance compared to fixed mounted molded case breakers in switchboard construction. This is true regardless of where the protector is mounted. A typical switchgear installation of a protector uses a low voltage switchgear compartment which is 96.00 inches (2438.4 mm) high x 44.00 inches (1117.6 mm) wide x 66.00–84.00 inches (1676.4–2133.6 mm) deep. The use of transition sections between the protector and switchgear ensures that sufficient space exists to route buswork between the two compartments.

Refer to **Figures 18.0-8** through **18.0-12** which illustrate typical plan views and front elevations for double-ended network substations and three transformer spot network designs. **Figure 18.0-8** shows the bus configuration of the two-unit spot network substation. Note that there must be a separate ground return neutral bus which has only one point of connection to the grounding conductor. This type arrangement permits selective tripping of the Tie, then the protector. For a line-to-ground fault on Bus #1, the 86T lockout relay controlling the Tie breaker will be operated first when GFR-T detects 1.0 per unit ground current. After the Tie breaker is open, the line-to-ground fault current is sensed only by GFR-1, which will actuate the 86-1 lockout to trip the network protector NP #1.

For primary faults, the network relay must be set such that it can respond to both reverse magnetizing levels of current as well as to any primary circuit fault current. Since most systems employ DELTA-WYE windings, primary faults will not be detected by either GFR-T or the GFR devices associated with the protectors, since no zero sequence current will flow. However, if GROUNDED WYE-GROUNDED WYE transformers are used, the relay coordination must be such that the network relay responds first to primary feeder faults. This permits the correct operation of the protector under such conditions,

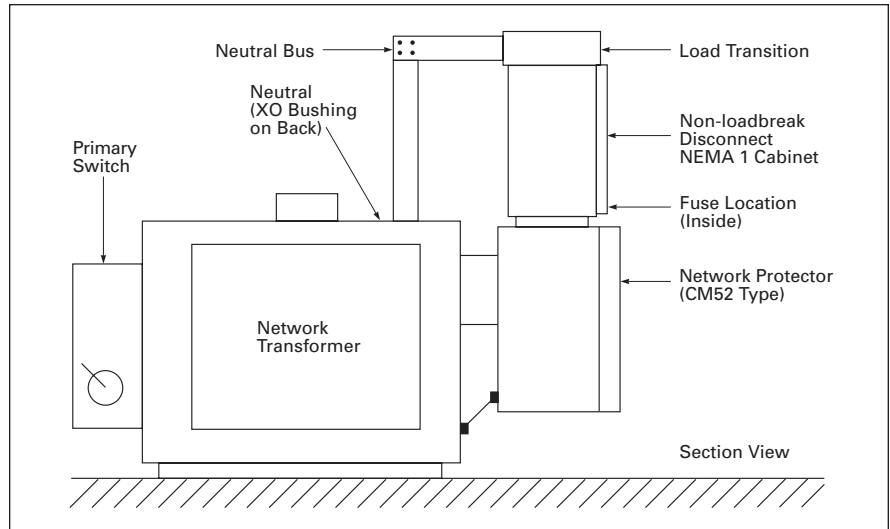

Figure 18.0-7. Typical Non-Loadbreak Network Disconnect Mounting Arrangement

because the GFR-T should not attempt to trip the Tie open. Therefore, power will be maintained on the low voltage bus with the Tie breaker remaining closed. See **Figures 18.0-9** and **18.0-11** for layout arrangements for dry-type and liquid-type spot networks respectively.

Figure 18.0-10 shows the bus configuration for a three-unit commercial spot network. Again, the ground return neutral bus is required which has only one point of connection to the grounding conductor. Selective tripping is achieved in the same fashion as the double-ended network substation with GFR-T sensing ground current and operating the 86T device which then opens both Tie breakers. The ground relays GFR-1, GFR-2 and GFR-3 will only sense ground current after the Tie 86 lockout is energized and the Tie breakers are open. Interlocking auxiliary contacts on the 86-T with the GFR circuits guarantees this selective tripping and ensures the user that ground currents are accurately measured. The ampacity of the ground return neutral bus must meet the minimum requirements of the neutral bus. It is prudent to size the ground return neutral bus the same size as the phase bus, since the ground and neutral carry fault currents during abnormal events.

The space required by the ground sensors and connecting buswork can be accommodated easily in two-unit spot networks. However, on three- and four-unit systems, the extensive structure-to-structure insulated ground bus plus the normal phase, neutral and ground buses can reduce the usage of four breaker cells in the

switchgear to three. Vendor designs vary on this issue. All four breaker cells are available on two-unit, three-unit, and four-unit systems from Eaton, when Magnum DS switchgear is used.

The ampacity of the phase and neutral buswork must meet the gross demand plus spare capacity for growth as stipulated by the National Electrical Code® for the loads served. If each transformer on a two-unit spot network has been sized with 100% redundancy, then each protector and load buswork should be rated to carry the entire load from one primary feeder and one transformer. Three-unit spot networks can reduce the redundancy to 50% for the same loads since two units remain in service. Four-unit spot networks may reduce the redundancy to 33%, unless the loads need to be served from two remaining services in which case 100% redundancy is still required.

6. Typical Spot Network Layouts

The amount of space available for the electric service will dictate the size and quantity of the network units chosen for a project. Double-ended substations, especially dry-type designs, tend to be arranged in a single lineup with the primary feeders located at opposite ends of the room. Refer to **Figure 18.0-9** for an example of this type of arrangement. The single lineup can be used if space permits. One alternative is to locate the transformers behind, or in front of the switchgear, with interconnecting busway or cables.

Commercial Spot Network Design Considerations

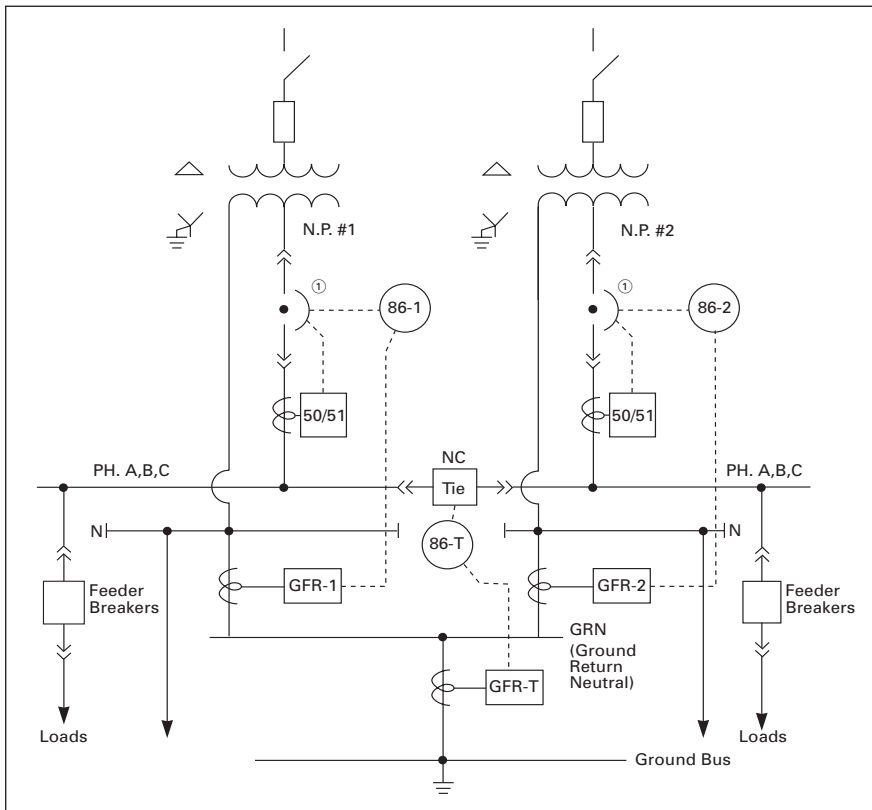

Figure 18.0-8. One-Line for Two-Unit Spot Network

① Protectors not fused.

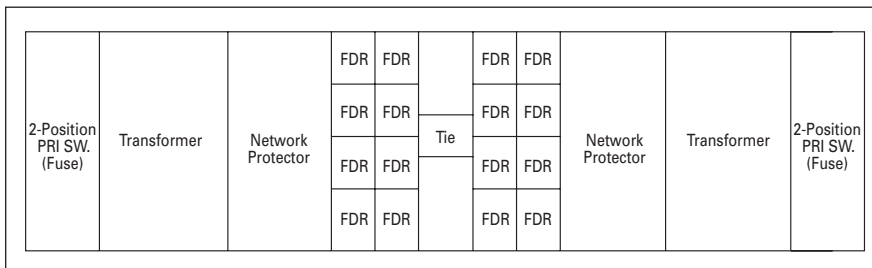

Figure 18.0-9. Front View of Double-Ended Network Substation

Three or more transformer unit spot networks cannot be arranged in one lineup, therefore they use the remote mounting of the transformers. Refer to **Figure 18.0-11** for an example of this type of equipment layout. It is important to remember which side or end of equipment is used for normal operations when designing a network layout. The primary switches are operated from the end as are the protectors. Switchgear needs both NEC clearances at the front and the rear, due to the drawout breakers and the rear accessible cable compartments. Designers are encouraged to pay attention to the different voltage levels present, both medium and low voltage, and the required working clearances given in the NEC or local codes.

Equipment weights should also be investigated to ensure that the structure can support the network assemblies. Means of egress and routes to remove material if replacement becomes necessary should be identified. Avoid placing any network equipment against any wall; the NEC clearances required probably double if two means of egress are not available. Structural columns pose challenges, however they rarely defeat network arrangements; avoid switchgear door openings bumping against columns before they are fully opened.

The highest piece of equipment may be the low voltage switchgear, which is usually 96.00 inches (2438.4 mm) in height, plus the 9.00–10.00 inches

(228.6–254.0 mm) required by a rail mounted top of gear breaker lifter device, or the network disconnect, and must be accommodated. Liquid transformer units have very high core and coil untanking heights, which precludes any chance of untanking the core and coils in a normal building. See **Figures 18.0-32 through 18.0-34**.

Regarding conductors, it is prudent to remember that busway can enter or exit a switchgear structure at only one location. Room does not exist to accommodate more than the first run of busway in a single section, unless the first connects at the top and the second connects at the bottom.

A typical plan view for a three-unit spot network is shown in **Figure 18.0-11**; four-unit spot networks are similarly designed. If it becomes necessary to split the switchgear assembly, position the splits at one side or the other of the Tie devices. This approach simplifies the power connections of the neutral and ground buses.

The number of network transformers used in a typical spot network is directly correlated with the number of independent, yet networkable primary feeders available. At least, that is a general rule to follow, however the secondary equipment can take many configurations.

Eaton recommends using at least one normally closed tie breaker in the low voltage metal-enclosed switchgear for the purpose of isolating ground faults, and for maintenance of the assembly (cleaning, torquing and testing). Usually the number of normally closed Tie breakers equals N-1, where N equals the number of transformers used in the spot network. However, for some projects it may be desirable to have a “ring” low voltage assembly where the number of Tie breakers equals N. In such a “ring” spot network, a Tie busway or cable connects the extreme left side bus of the assembly to the extreme right side bus, thus keeping the N-1 network configuration even when one primary or network transformer is down, or the low voltage assembly bus is down for maintenance or fault isolation.

Main breakers, when used, may be positioned in switchgear that is one integral lineup, or mounted in switchgear close-coupled to dry-type transformer/protector pairs which feed power circuits to remote assemblies having all Tie and Feeder breakers.

Commercial Spot Network Design Considerations

Historically, some users and designers have recommended using low voltage busway as the spot collector bus, then feeding loads radially from the collector bus. Eaton does not recommend low voltage busway as the network collector bus, since it has limited short-time ratings and has higher failure rates than the more robust low voltage metal-enclosed switchgear. It is certainly acceptable to use multiple segments of busway to feed protector circuits into the switchgear, where the redundancy of busway prevents loss of power to loads for a single busway fault or failure, and the available fault currents are limited to levels that can be delivered by one transformer, not N transformers.

Control voltages for network protectors are usually 120 Vac and derived internally from the transformer secondary or within the protector itself, thus protectors are self-contained regarding control power. The low voltage switchgear assembly may be ac or DC with AC control power being more popular. The ac current control systems use a control power transformer on the incoming of each protector circuit with a control power transfer system on the secondaries of all control power transformers to pick the first live source. The control power circuits are always energized so long as at least one protector is closed.

The addition of main meters for power monitoring, overcurrent relays and communication trip units generally take very little space and can be accommodated without adding space if the switchgear layout rules and standards are followed. It is possible to monitor other non-switchgear equipment by adding space for the required number of communicating addressable relays which monitor remote contacts wired to the switchgear for status and alarming at a remote power monitoring and control system, such as transformer temperature and pressure alarms.

7. Use of Current Limiting Fuses

Generally, this issue needs to be addressed in the design stage of a project, prior to specification writing. Protectors are usually applied with fuse limiters on the load side of each protector, but there can be exceptions to using the limiters.

The expected fault currents need to be calculated for several locations, including secondary windings of transformers, network switchgear bus (both sides of

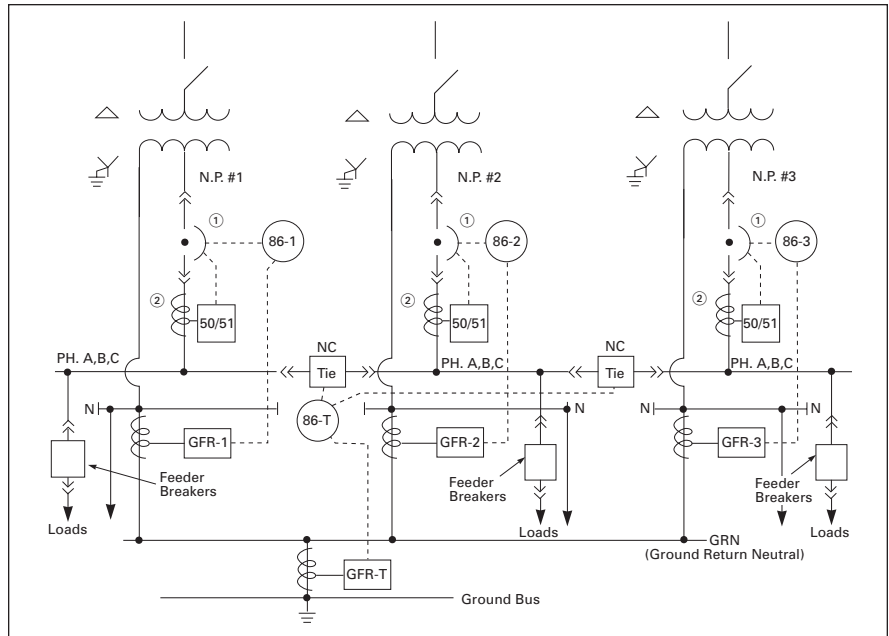

Figure 18.0-10. One-Line for Three-Unit Spot Network

- ① Protectors are fused for three- and four-unit spot networks.
- ② Fuse location.

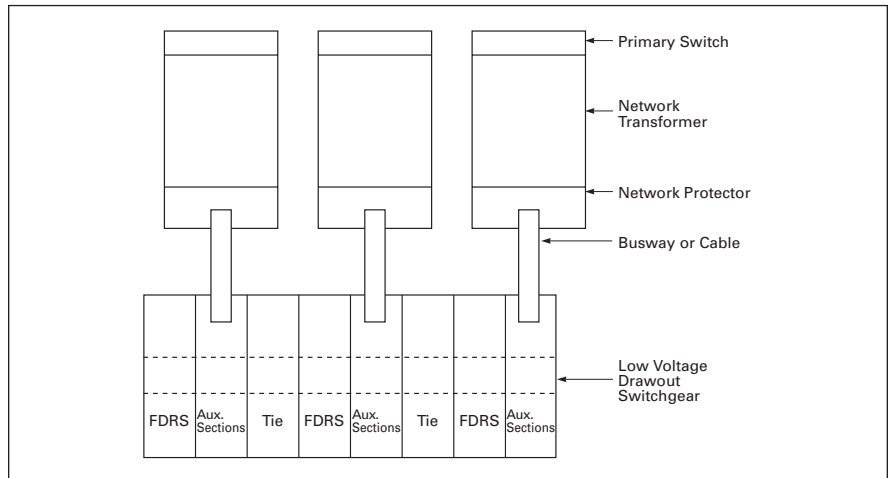

Figure 18.0-11. Floor Plan for Three-Unit Spot Network System

Tie breakers), and at the load side of feeder breakers. Network systems that use air power breakers and deliver more than 65,000A of fault current should use feeder breakers such as Eaton’s Magnum™ DS breakers rated up to 100,000A.

Network protectors are normally equipped with load side fuses (usually partial range current limiting) and serve as backup protection should the protector fail to open on reverse fault current conditions. Air power breakers are now available with kAIC ratings of 65, 85, 100 and 200 kAIC, without fuses.

In two transformer spot networks, one can argue that the protectors do not need to be fused for any application up to and including 3000 kVA transformers. The principal logic is that the Tie can experience only the fault current from one transformer and that the Tie protective trip settings provide faster acting backup protection than the protector fuses for reverse power conditions.

When protector fuses are used, the system needs to be designed with interlocking to ensure that the fuses are not accessible unless the protector and disconnect are opened.

Commercial Spot Network Design Considerations

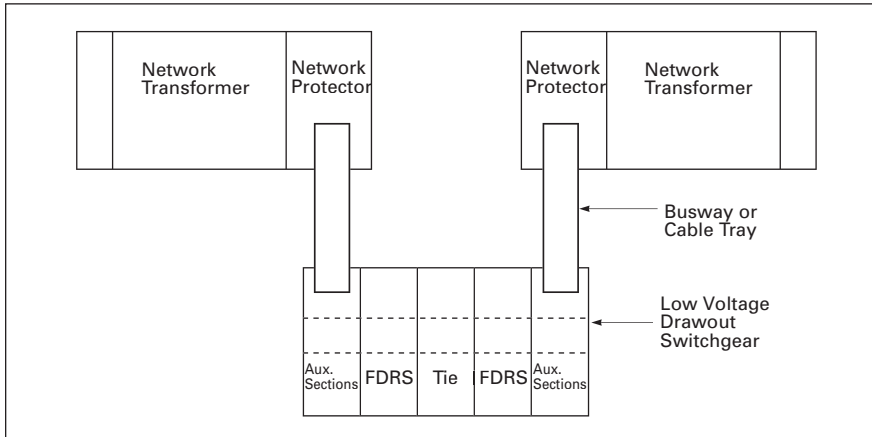

Figure 18.0-12. Floor Plan for Double-Ended Network Substation

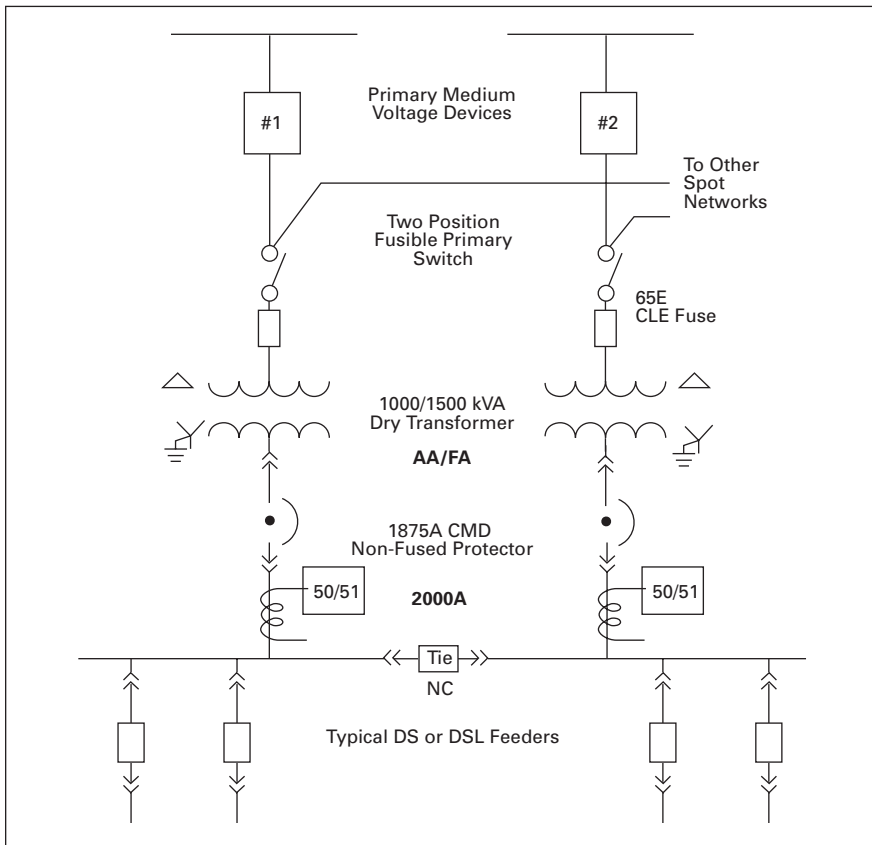

Figure 18.0-13. Example of Two-Unit Spot Network Coordination Issues

8. Network Device Coordination

By way of example, we shall illustrate the level of coordination possible in a typical two-unit network system as shown in Figure 18.0-13. In this example, two networkable primary sources are available and several transformers are presumed to be fed from each of the two primary circuits. The upstream primary device is a 13.8 kV vacuum circuit breaker with a complement of relaying.

The medium voltage switches are fused air type. The switches have two positions, open and closed, not three positions. We recommend that the primary switches use key interlocks with protectors to ensure that the protectors are used to break and make load currents, although this interlocking is not absolutely necessary since the switches are loadbreak rated. The lack of a ground position in the primary switches does not impede the normal operation of the network system;

rather it makes grounding the primary cable a manual procedure.

In this example, a two-unit network with 1000/1500 kVA dry transformers AA/FA, 80°C rise are used. The transformers are configured delta-wye with 13.8 kV primary, a 480V wye secondary, and the impedance of each is within the range of 5.75–7.00%. Eaton Type CM52 Network Protectors are rated 1875A and are mounted within low voltage switchgear structures. The CM52 is a deadfront, drawout protector whose operation is very similar to the air power circuit breaker used throughout the switchgear to distribute power to the outgoing circuits. The network relay used within the CM52 is the MPCV type, a microprocessor-integrated solid-state relay that allows for field programming the network characteristics. All CM52 protectors are factory wired for application of remote trip and lockout functions, which will be used in our example via the 86 lockout relay and separate 50/51 protective relay.

The 50/51 relay will use 2000/5 ratio current transformer inputs from current transformers mounted on the load side of each protector within a transition box. The 50/51 device may be a solid-state relay, Digitrip 3000, due to its broad range of field programmable settings. Thus, the protectors are used as main overcurrent protective devices as well as protectors. When transformers are remote from the switchgear, the current transformers must be located within a transition box atop the protectors. The current transformers may be used for metering also, or if more accurate metering at lower current levels is desired then a second set may be necessary in the switchgear with multi-ratios to match the average load demands.

The low voltage assembly uses Eaton Magnum DS breakers for both Tie and Feeder devices. The Tie breaker will be an MDS-620, 2000A frame, 1600A trip, electrically operated, drawout design, incorporating the Digitrip 520 trip unit. The feeder breakers are a mix of 800A frame and 1600A frame to serve the outgoing feeder circuits. The switchgear will panel mount the two 50/51 relays, which provide overcurrent protection for the protectors.

In this example, the fault currents are less than 65 kA; however, systems having higher fault currents can be accommodated using higher-rated Magnum DS breakers.

Commercial Spot Network Design Considerations

General Discussion—Coordination Curves

The protective device settings for a two-unit spot network are similar to those used for a standard double-ended substation. The goal is to serve both continuity of service and protection equally. Settings should not favor either one or the other, but rather should keep loads served if at all possible and minimize nuisance outages even under serve fault conditions, including ground fault events. Basically, settings should be implemented which allow the closest upstream device near a fault to clear before other upstream devices trip. Faults in a network have more than one source, which is a major difference compared to double-ended substations with a normally open Tie breaker.

In **Figure 18.0-14**, we plot the time-current curves of the medium voltage power fuses, whose main function is to provide short circuit protection to each transformer, the ANSI damage curve typical for the transformers, the 50/51 relaying upstream from each spot network, the Tie and Feeder device trip curves, and the 50/51 relaying used by each protector. We have shown the primary 50/51 protective relaying curves by postulating their relative position as being to the right of each damage curve and to the left of primary cable damage curves, since several transformers are served by each primary service. In other words, several vault locations exist in the facility. Obviously, these primary relays cannot protect each transformer individually, nor is it desirable to do so since it is better to isolate a simple faulted transformer with a power fuse than to open the entire primary circuit.

The following paragraphs detail the protective device settings, discuss the curves, and review the important issues.

ANSI Transformer Damage Curves

Two curves are plotted: both the 100% and the 58% damage curves are shown for the dry types in our example. These curves are defined in ANSI Standard 141. The 58% curve reflects the fact that a one per unit secondary fault on a grounded wye transformer creates a 0.58 per unit fault in the primary conductors when the primary windings have a delta configuration.

Eaton CLE 65E Power Fuses

The selected current limiting fuse, 65E, provides little if any overload protection for the transformer, however, it does an acceptable job of supplying NEC code mandated short circuit protection for the 100% damage curve. The fuse cannot provide protection for the 58% curve and downsizing the selected rating lower than 65E is likely to result in nuisance fuse operation. Each power fuse vendor has applica-

tion tables and charts to properly select fuses for any application.

The fuse meets the NEC stipulated protection, but lacks the flexibility of a relay with nearly continuous adjustments. If superior protection is desired, then a vacuum breaker with 50/51 relaying should be used in lieu of the fused primary switch. Do not use 50/51 relaying on a load interrupter switch.

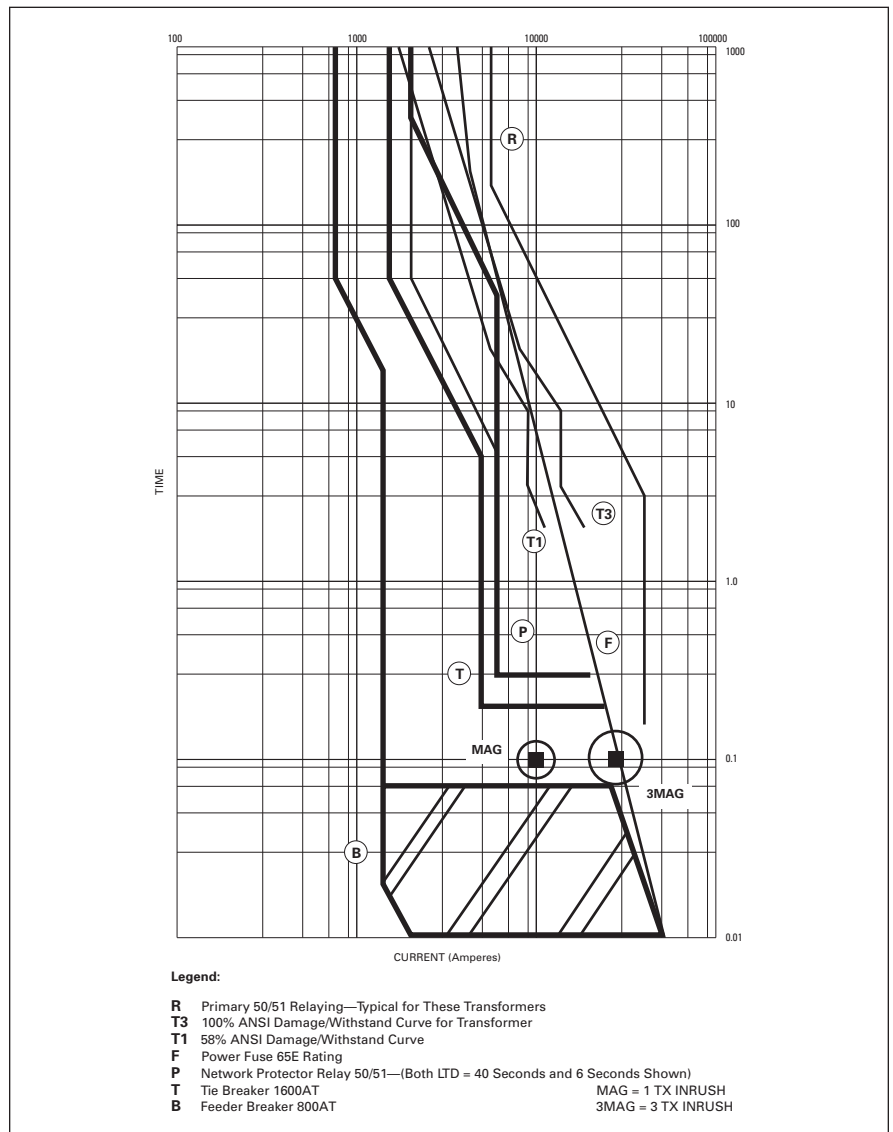

Figure 18.0-14. Two-Transformer Spot Network Phase Overcurrent

Commercial Spot Network Design Considerations

Protector Relaying—Eaton Digitrip 3000 Plus Ground Fault Relay (GFR)

Network relays do not have any form of forward 50/51 (instantaneous and time overcurrent) protection, therefore if it is desired it must be added separately. An 86 lockout relay is recommended for positive lockout indication and reset operations. The curve for the Digitrip 3000 is shown in **Figure 18.0-14** and depicts the settings for this microprocessor-based solid-state multi-phase relay. Using the 2000/5 ratio current transformers, the settings are as follows:

Long Time Pickup (LTPU)	= 1.0 (2000A)
Long Time Delay I^2t (LTD)	= 40 seconds
Short Time Pickup (STPU)	= 3 X (6000A)
Short Time Delay (STD)	= 0.3 seconds
Instantaneous (INST)	= 11 X (22000A)
Ground Fault Relay (GFR)	= 700A pickup
Ground Fault Relay (GFR)	= 0.58 seconds (35 cycles)

It is very important that the protector 50/51 settings be slower than the Tie breaker. The faster acting Tie is desired for isolation of switchgear faults between one side of the Tie and the loadside of a protector without taking the whole network down. The Tie clears one transformer's fault contribution, while the unfaulted side remains energized. The protector experiencing the remaining fault current will subsequently trip open, thereby isolating one-half of the network bus for repair.

Faults located in the transformer secondary windings may open both the Tie and the protector, depending upon the magnitude of the event. The protector should open first upon reverse power, since protectors respond to reverse power in 7 cycles. If the Tie also trips open, the Tie can be reclosed to serve the entire load again after locking out the protector on the faulted transformer.

Note: The transformer is given superior overload protection by the Digitrip 3000 compared to the level of protection given by the power fuse. This is especially true even in the overload region of the ANSI damage curve.

Tie Breaker—Eaton MDS 2000A with Digitrip LS Plus Ground Fault Relay

The settings shown in **Figure 18.0-14** were developed using 2000/5 sensors on the Tie breaker. The settings recommended are:

Long Time Pickup (LTPU)	= 0.8 (1600A)
Long Time Delay I^2t (LTD)	= 2 seconds
Short Time Pickup (STPU)	= 3 X (4800A)
Short Time Delay (STD)	= 0.2 seconds
Instantaneous (INST)	= Not used
Ground Fault Relay (GFR)	= 700A pickup
Ground Fault Relay (GFR)	= 0.58 seconds (35 cycles)
	See Figure 18.0-15

These settings allow the Tie to act quickly for abnormal current conditions, yet also provide enough delay to allow protectors to trip on reverse current when protector operation is the prudent first course of action. Also, larger feeder devices, such as 1200A breakers (not shown in **Figure 18.0-14**) will easily fit to the left and beneath the Tie curve. It is important to set the Tie to operate quicker than the protector 50/51 relaying. The faster Tie settings assure that switchgear bus faults do not take the entire service down (only half). In our example, the Tie will only be called upon to interrupt the fault current from one transformer.

Typical Feeder—Eaton MDS 800A with Digitrip LSIG

The settings in **Figure 18.0-14** were generated using 800/5 sensors applied on the feeder breakers. The Digitrip 520 trip unit settings are:

Long Time Pickup (LTPU)	= 1.0 (800A)
Long Time Delay (LTD)	= 2 seconds
Short Time Pickup (STPU)	= Not used
Short Time Delay (STD)	= Not used
Instantaneous (INST)	= 2 X (1600A)
Ground Fault Pickup (GFPU)	= F (500A)
Ground Fault Delay (GFD)	= 0.3 seconds (18 cycles)
	See Figure 18.0-15

These settings provide for fast action of feeder devices experiencing the maximum fault duty of the switchgear (fault current from two transformers). Ground fault protection is recommended for the feeder trip units; these settings can be coordinated with the two-stage ground fault detection system (single point ground return method) mentioned earlier in **Figure 18.0-8**. Suggested ground fault protective device settings are illustrated in **Figure 18.0-15**, and the settings are listed under the protector, Tie breaker, and feeder device discussion in this section.

Commercial Spot Network Design Considerations

Ground fault settings are established essentially the same as a double-ended substation using a single tee ground point and ground return methodology. Eaton's MDS feeder breakers are set to coordinate with downstream devices so that downstream breakers experiencing a fault trip first. The GFR relays for the Tie and protectors are set slightly higher in pickup and have a longer delay than the ground fault for the feeder devices. Protector and Tie ground fault settings are usually set at the same levels; coordination is achieved by interlocking the two stages so that the Tie stage operates first followed by the protector stage. Ground current originating from faults in the switchgear buswork or incoming conductors is directly measured by the GFR on the Tie, then by one of the protectors after the Tie opens. Subsequently, the GFR on the faulted zone causes the protector experiencing the fault to trip open thereby isolating the fault completely. Downstream ground faults are cleared by downstream circuit breakers or the DS feeder breaker serving the faulted circuit.

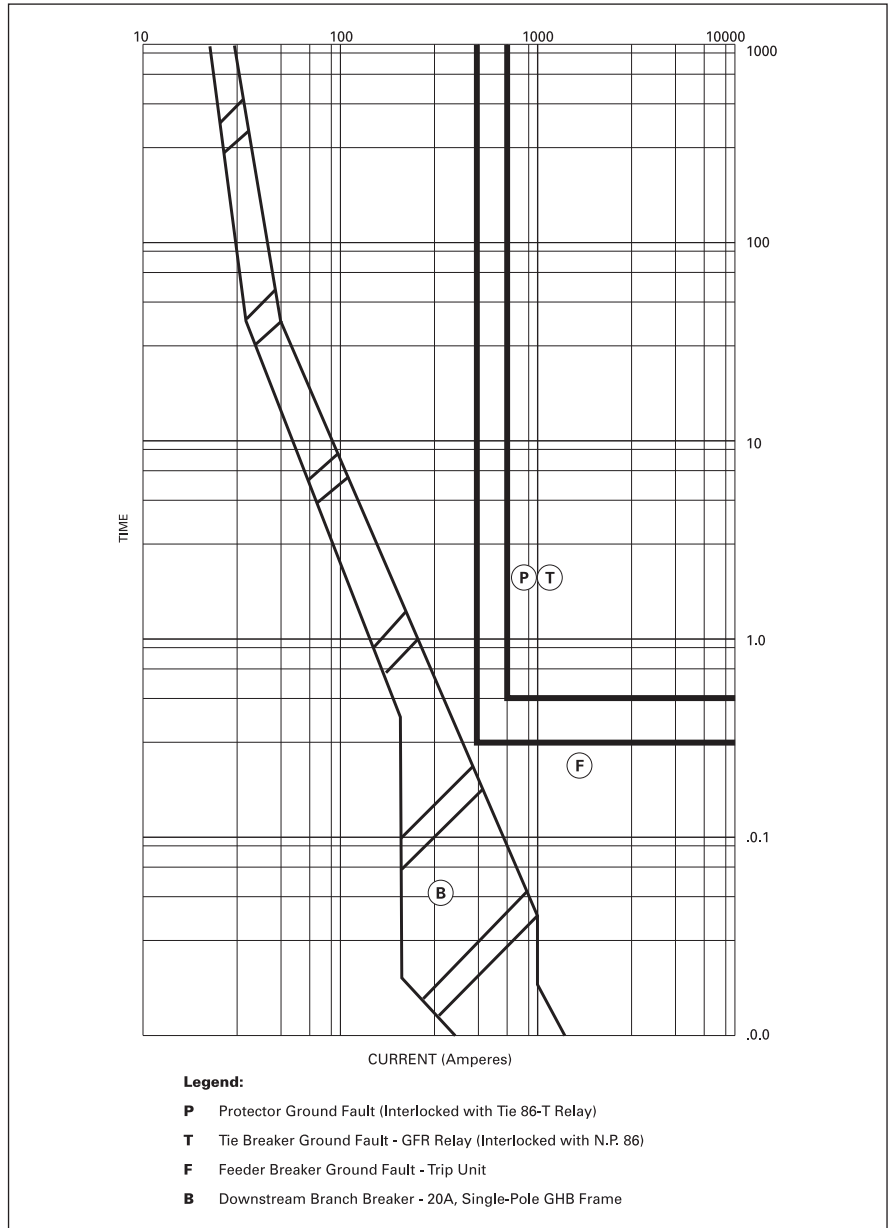

Figure 18.0-15. Spot Network Ground Fault Protection

Liquid-Type Network Transformers

Liquid-Type Network Transformers



Typical Liquid Network Transformer

Network transformers are available with liquid immersed core and coil assemblies, and use the liquid as the principal insulation means for primary and secondary windings. The fluid can be mineral oil, silicon or a biodegradable form of vegetable oil. Indoor applications benefit from using silicon or the biodegradable vegetable oil liquid dielectric. See the discussion below for ABB's BioTemp fluid.

The transformers are built to ANSI C57.12.40 standards and have an integral primary non-loadbreak three-position switch having connected, open and grounded positions. The grounded position grounds the incoming medium voltage feeder that serves the transformer, and does not ground the primary windings.

The primary switch is interlocked with the associated network protector and secondary transformer windings to ensure that the switch is only used to break or make magnetizing current.

Liquid network transformers have a special low voltage flange for field mounting a network protector on the secondary flange. The protector is best mounted close to the secondary windings of the associated transformer to minimize distance between the windings and the protector contacts. There are only two standard ANSI flange configurations, smaller and larger, and the user generally gets one based upon the transformer kVA size. It is possible to chose one over the other, but the specifier must be careful in the selection and make certain adequate load growth and redundancy are built into the system when choosing a small flange size for a transformer that normally is supplied with a large flange for a higher ampacity protector. If the specifier stays with the Eaton recommendations for sizing protectors, the flange size is properly chosen for every unit.

Liquid transformers are available with an array of accessories, most of which are listed on the next page with the outline drawings of a typical liquid network transformer. Alarm contacts are usually wired to terminal boxes for use on alarm schemes or monitoring. Certain accessories allow for the sampling of fluids at regular maintenance intervals for testing and analysis.

BioTemp Advantages

BIOTEMP® is a natural ester fluid made from renewable and biodegradable vegetable-based oil. Below are some of the environmental, fire safety and operational advantages of using BIOTEMP.

Environmental Advantages

- Even though secondary containment is still required, BIOTEMP spills can be disposed through normal means and not treated as hazardous or toxic waste
- BIOTEMP minimizes air pollution by producing only carbon dioxide and water during combustion
- BIOTEMP also offers the potential for relief from government regulatory penalties, resulting in less costly spill cleanups

Fire Safety Advantages

- BIOTEMP offers greater risk mitigation on collateral damage from transformer explosion and fire, potentially lowering insurance premiums
- Active fire suppression and barrier walls can essentially be eliminated with BIOTEMP when minimal spacing is maintained
- BIOTEMP can alternatively be used safely indoors and in tighter spaces outdoors typically without additional fire safety requirements
- BIOTEMP is listed as a "less flammable" dielectric fluid by Factory Mutual (FM Global) and is classified as a "less hazardous" dielectric medium in respect to fire hazard by Underwriters Laboratories (UL)

Operational Advantages

- BIOTEMP impregnated paper experiences a much lower aging rate compared to mineral oil impregnated paper, leading to an increase in the insulation system lifetime (grid reliability)
- BIOTEMP impregnated paper can alternatively operate at a higher hotspot temperature and attain the same life expectancy as mineral oil impregnated paper, increasing the transformer peak load or overload capacity (energy efficiency)

Table 18.0-2. Typical Properties of Insulating Fluids

Description	BIOTEMP	Mineral Oil	H.T.H.	Silicone	
Electrical					
Dielectric strength, kV (ASTM D877)	45	30	40	43	
Physical					
Viscosity, cST.	100°C	10	3	11.5	16
(ASTM D445)	40°C	45	12	110	38
	0°C	300	76	2200	90
Flash pt. °C	(ASTM D92)	330	145	285	300
Fire pt. °C	(ASTM D92)	360	160	308	330
Specific heat (cal/gr/°C) (ASTM D2766)		0.47	0.43	0.45	0.36
Coefficient of expansion, /°C (ASTM D1903)		6.88 x 10 ⁻⁴	7.55 x 10 ⁻⁴	7.30 x 10 ⁻⁴	1.04 x 10 ⁻³
Pour pt. °C	(ASTM D97)	-15 to -25	-40	-24	-55
Sp. gravity	(ASTM D1298)	0.91	0.91	0.87	0.96
Color	(ASTM D1500)	<0.5	0.5	0.5-2.0	<0.5
Environmental					
Biodegradation Rate (%) 21-day CEC-L-33	97.0	25.2	27.1	0.0	

Liquid-Type Network Transformers

- ① Sealed Tank—Braced for 15 PSI (103 KPA)—Color Network Black.
- ② Base-Bar Type—0.75 (19.0) x 1.50 (38.0).
- ③ Jacking Areas—4 Total.
- ④ Lifting Hook for Lifting Complete Transformer.
- ⑤ Welded Cover with Gasket and Lifting Loops for Lifting Cover Only.
- ⑥ 1.00 (25.4) Filling and Upper Filter Connection.
- ⑦ Bolted Manhole—12.50 (318.0) x 12.50 (318.0) Opening with Cortite Gasket.
- ⑧ Relief Device—Over a 7.00 (178.0) Handhole.
- ⑨ Cap with 2.00 (51.0) Square Head for Access to De-energized Tap Changer (with Key Interlock, Coordinated with HV Switch). Item ⑫.
- ⑩ LV Throat—Per ANSI C57.12.40 Figure 3.
- ⑪ LV Bushing—3 Total.
- ⑫ XO Bushing Style 8D11227G02—Spade 1.75 (44.0) NEMA Drilled. 3.75 (95.0) Wide x 0.5 (13.0) Thick Spade.
- ⑬ 1.00 (25.4) Drain Valve with Bronze Pipe Plug.
- ⑭ Ground Pads—2-Hole NEMA Drilling—02 Total.
- ⑮ Magnetic Liquid Level Gauge with Alarm Contacts.
- ⑯ Vacuum Pressure Gauge with Alarm Contact and Air Test Valve.
- ⑰ Liquid Temperature Gauge with Alarm Contacts.
- ⑱ Rapid Pressure Rise Relay.
- ⑲ Control Cabinet—with Undrilled Entrance Plate.
- ⑳ Bolted Manhole—12.50 (318.0) x 12.50 (318.0) Opening with Cortite Gasket.
- ㉑ H.V. 3-Position Magnetic Break Disconnect and Grounding
- ㉒ Switch Operating Mechanism with Provisions for Padlocking, with Key Interlock. Locked in Open or Ground Positions, Coordinated with Tap Changer. Item ⑨ and Second Key Interlock. Locked in Closed Position and Coordinated with Low Voltage Protector.
- ㉓ 1.00 (25.4) Filling Coupling.
- ㉔ Magnetic Liquid Level Gauge.
- ㉕ Switch Positions—Top to Bottom, Ground, Closed, Open.
- ㉖ Switch Cover with 0.50 (13.2)—3 Taps for Jack Screws (Bolted on).
- ㉗ Terminal Chamber Cover with 0.50 (13.2)—3 Taps for Jack Screws (Bolted on).
- ㉘ Nameplate and Warning Plate.
- ㉙ H.V. Terminal Chamber.
- ㉚ 1.00 (25.4) Drain Coupling.
- ㉛ Terminal for #2 to 4/0 Cable Range—3 Total.
- ㉜ Entrance—3 G & W Stuffing Boxes. Catalog Number RS33-G1, 4.50 (114.0) CL to CL.
- ㉝ 0.50 (13.2) Air Test Fitting with Bronze Pipe Plug.
- ㉞ 0.50 (13.2) Top Liquid Sampler with Bronze Pipe Plug.
- ㉟ 0.25 (6.0) Fluid Level Plug.
- ㊱ Interlock Bushing.

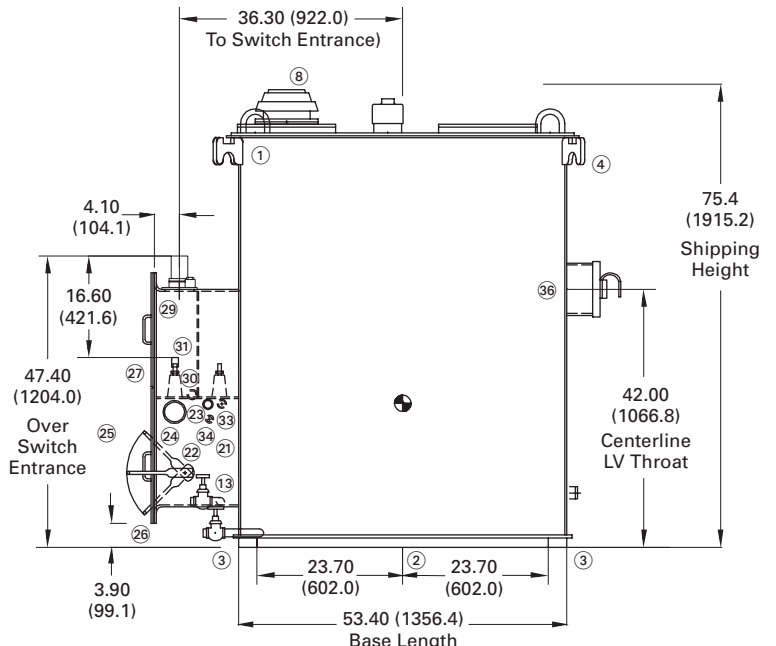
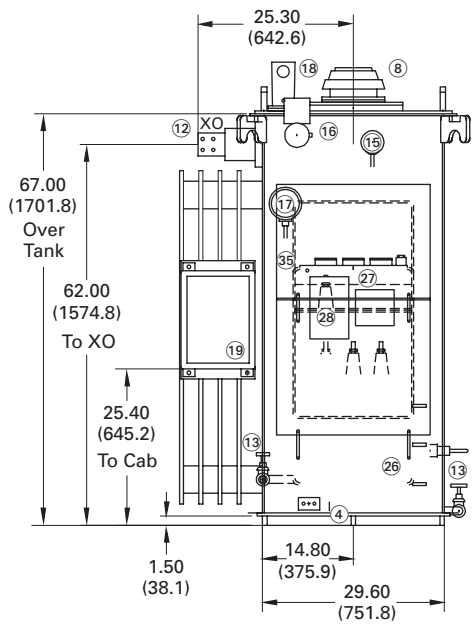
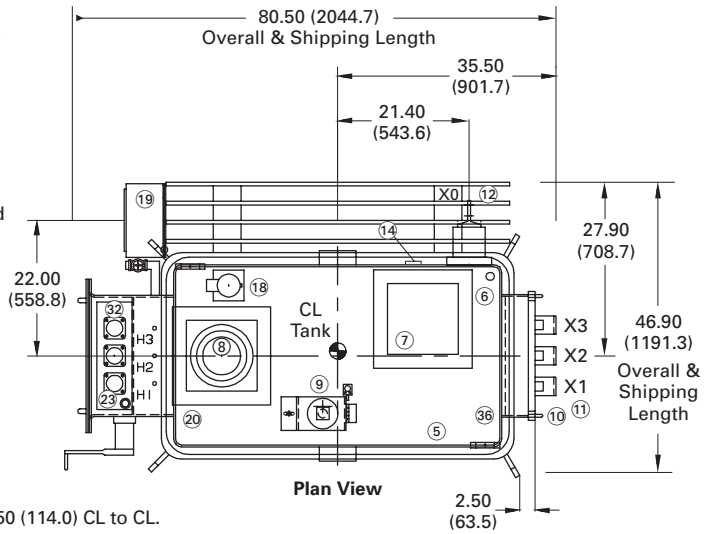

Figure 18.0-16. Outline Drawing—750 kVA, 55/65°C Rise, 13,750 Delta to 480Y/277 Volts

Dry-Type Network Transformers



Typical Dry-Type Network Transformer

Network transformers are available with dry-type core and coil assemblies, and use special polyester resin or cast epoxy as the principal insulation means for primary and secondary windings. The choice depends upon the economics of the project. Indoor applications benefit from using dry-type networks since no containment or sampling of liquid dielectric is needed. Eaton strongly recommends 80°C rise cast coil transformers for use in spot network systems.

The transformers are built to ANSI C57.12.57 standards and do not have an integral primary switch, unless a two-position switch is added in the field. The process of grounding the incoming medium voltage feeder that serves the transformer becomes a manual process of adding grounding cables. The two-position primary switch is usually loadbreak rated and is not interlocked with the associated network protector and secondary transformer windings.

Eaton can also supply close-coupled primary switchgear with a two-breaker (VCPW) transfer capability on the primary of cast coil dry-type network units. The proximity of vacuum breakers will mandate using RC snubbers within the transformer.

Dry-type network transformers have a special low voltage flange for field mounting a network protector on the secondary flange. The protector is best mounted close to the secondary windings of the associated transformer to minimize distance between the windings and the protector contacts. There are only two standard ANSI flange configurations, smaller and larger, and the user generally gets one based upon the transformer kVA size. It is possible to choose one over the other, but the specifier must be careful in the selection and make certain adequate load growth and redundancy are built into the system when choosing a small flange size for a transformer that normally is supplied with a large flange for a higher ampacity protector. If the specifier stays with the Eaton recommendations for sizing protectors, the flange size is properly chosen for every unit.

Dry-type transformers can be close-coupled to LV drawout switchgear with protectors, tie and feeder devices all switchgear mounted.

Dry-type network transformers are available with an array of features, most of which are listed on the next page with the outline drawings of a typical dry network transformer. A transformer monitoring package is usually included with temperature readings, RTDs and Alarm contacts. Most designs have knock-down enclosures for ease in rigging a unit into position through hallways and doorways.

Dry-Type Network Transformers

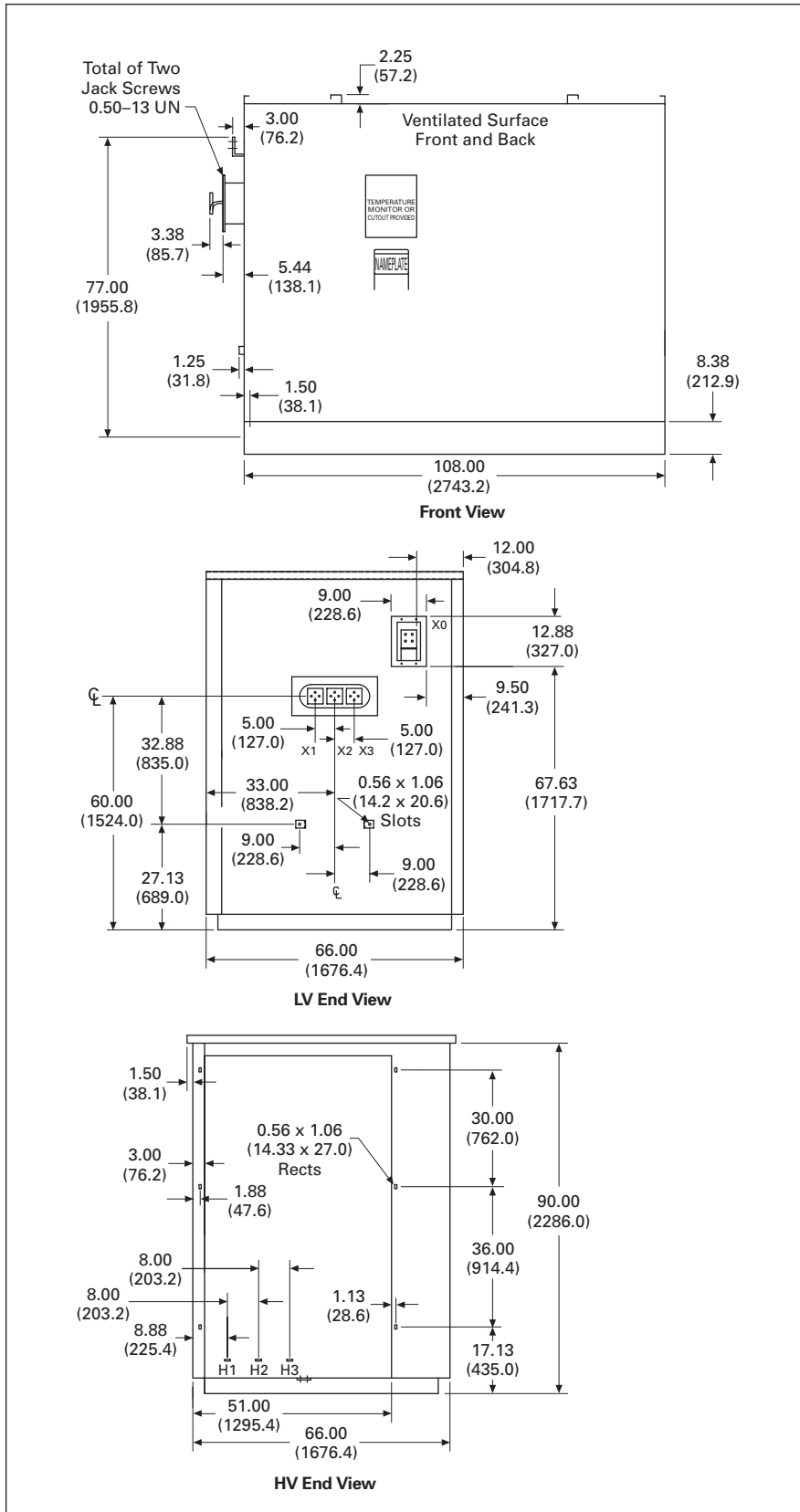

Characteristics

- Enclosure: NEMA 2 (indoor ventilated with drip-proof roof)
- Finish: ANSI 61
- Product type: Cast/Cast
- kVA: 1000/1500
- HV: 13,200
- HV kV BIL: 95
- LV: 480Y/277
- LV kV BIL: 10
- Taps: 12,540/12,870/13,200/13,530/13,860
- Impedance: 5%
- Temperature rise: 80°C
- Cooling class: AA/FA
- Hertz: 60
- Phases: 3
- LV windings: Cu
- HV windings: Cu
- Sound level: 64 dB
- Approximate weight: 10,200/4627 lbs/kg
- Provisions for mounting network protector on the left end
- Primary is cable connected to closed coupled primary switchgear, such as MVS

Accessories

- Braced for seismic
- ANSI 61
- LV end sheets
- Standard ventilation
- Aluminum screens
- Copper ground bus (0.25 x 2.00)
- Neutral disconnect link
- UL listing
- Control panel
- Control power supplied by ABB
- Forced cooling

Figure 18.0-17. Outline Drawing—1000/1500 kVA Cast Coil Network Transformer, 80°C/100°C Rise, 13,800 Delta to 480Y/277 Vac Wye

Type CM52 Network Protectors



Typical Enclosed CM52 Network Protector

Quality Designed to be Smarter, Safer and Streamlined

The CM52 Network Protector provides the highest level of reliability and service continuity available today. An intelligent protective device, the CM52 Network Protector is designed to handle ratings from 800 to 4500A, 216 to 600V. This new network protector features an electrically operated, composite case, spring closed air network circuit breaker controlled by the MPCV network relay.

The CM52 meets or exceeds the standards in IEEE® C57.12.44. This ensures a product with the highest performance standard applicable to a network protector. A first for network protectors, the CM52 is setting a new standard by being UL-qualified. This third party approval certifies the delivery of a quality product. A UL-qualified network protector means easier code approval for quicker system start-up and less approval time and costs in a non-utility environment.

UL listed and labeled CM52 protectors are presently available through 4500A. Contact Eaton and the protector product line for more details on UL listed and labeled CM52 network protectors.



CM52 Drawout

Network Protector Ratings

Several network protector models currently exist to satisfy all location requirements. The new CM52 design covers all of these ratings, giving you one type of protector to handle all installation needs. The styles available include internal or external fuse mountings and submersible or NEMA 4 enclosures throughout the current and voltage ratings. Having parts and accessories common through all protector ratings means lower maintenance and inventory costs. The CM52 was also designed with higher interrupting and fault close ratings than older protector models. This higher rating allows for safer installations and better protection on a network system.

Table 18.0-3. CM52 Ratings Table—Ratings through 480 Volts Wye

Continuous Current Rating	Interrupting Rating	Close and Latch Rating	Suggested Transformer Rating (kVA)	
			216V	480V
800	42	35	225	500
1200	42	35	300	750
1600/1875	42	35	500	1000
2000	42	35	600	1000
2500/2825	65	45	750	1500
3000	65	45	1000	2000
3500	85	65	1000	2000
4500	85	65	1000	2000

Type CM52 Network Protectors

Type CM52 Network Protectors



CM52 Secondary Contacts

Protector downtime is both frustrating and costly. No mechanism adjustments, few replacement parts, color-coded wiring, diagnostics, and a protected motor are key contributors to the high-level service reliability and reduced downtime of the CM52 Network Protector.



CM52 IDM

The CM52 is a low maintenance network protector. It requires no mechanism adjustments, is easier to troubleshoot and has built-in diagnostics. Maintenance time is no longer needed for the adjustment of protector contacts. Troubleshooting is much easier with the CM52 through color-coded wiring and a front accessible test block. Diagnostics are built into the Indicating Diagnostic Module. The IDM replaces the traditional manual adjustment of the min. motor pick-up adjustable resistor and offers diagnostic indicators for available control voltage for the motor, spring release and trip circuit. With the new CM52, maintenance becomes easier and protector downtime decreases, saving money and increasing reliability.

Much more manageable at less than half the weight of older network protectors, the protector is easier to handle, resulting in less time in vaults, and lower labor costs. A four-position, drawout, deadfront circuit breaker makes testing quick and safe, curbing maintenance time and costs. The deadfront provides worker safety, drastically reducing the possibility of live electricity accidents during inspection. A front accessible 6-point test block provides safe and easy connection of test equipment during testing, phasing and troubleshooting.

Quality was the focus through the design to the manufacturing of the new CM52 Network Protector. The circuit breaker in the CM52 goes through a 100-point testing procedure in an ISO® 9000 breaker specialty plant. The quality design and testing of the CM52 virtually eliminates the need for later adjustments and insures a reliable product.

The Intelligence of the Protector—MPCV Relay

Within the CM52 lies its intelligence, the MPCV Network Relay. The programmable MPCV Network Relay brings the proven performance of microprocessor-based technology to the CM52 Network Protector.

This programmable relay offers multiple selections to meet the requirements of each network protector installation. With the MPCV, you can select between the traditional straight-line master close curve and modified circular close curve. Our enhanced sequence-based algorithm provides exceptional performance and stability over a wide range of temperatures and voltages in comparison with a power-based algorithm. Additionally, the anti-pumping feature on the MPCV relay protects the motor under damaging system conditions.

Communications

The MPCV relay has built in communication capabilities for monitoring and control of the network protector. This allows users to access and display information from the relay including voltage, current, energy usage, power quality, and last trip details. Control of the protector is possible from a remote location, providing safer conditions and quicker response time.

The relay can also communicate other information about the network protector's environment through standard auxiliary inputs. Information such as water or pressure loss inside the network housing, or erratic internal enclosure temperature will send an alert notifying of problems in the vault.

The relay has the capability of communicating information to a Data Concentrator/Translator (DC/T) over a shielded twisted pair of communications wires. Information is obtained through a utility's SCADA protocol and/or Eaton's PowerNet software program.

Type CM52—Features, Functions and Benefits

Features, Functions and Benefits

1. **Standardized Breaker Frames:**

Only three basic breaker frames of minimal physical size are used throughout the CM52 to provide different electrical ratings.

Table 18.0-4. CM52 Sizes

Ampere Rating	Breaker Size—Inches (mm)		
	Width	Height	Depth
800–2000	17.00 (431.8)	17.00	17.00
2250–3000	22.00 (558.8)	17.00 (431.8)	17.00 (431.8)
3500–4500	35.00 (889.0)		

2. **Light Weight Breaker Element:**

A reduced breaker physical size also results in a substantial weight reduction compared to existing Network Protector designs.

Table 18.0-5. CM52 Weights

Ampere Rating	Weight in Lbs (kg)	
	CM52 Breaker Element	Comparable Breaker
800–2000	170 (77)	400 (182)
2250–3000	185 (84)	550–650 (250–295)
3500–4500	350 (159)	700–1300 (318–590)

3. **10 kV BIL (Basic Impulse Level):**

Impulse testing is the application of a high surge voltage on equipment to simulate possible surges caused by lightning. Although not defined or required by IEEE/ANSI C57.12.44, this test provides an additional measure of safety and performance to the design. (The test was performed at 1.2us x 50 us wave shape on a 3 x 3 grid.)

4. **Deadfront Drawout Breaker:**

Protects the user from accessing live circuits. Eaton offers the only deadfront drawout breaker designs in the Network Protector industry.

5. **Improved Interrupting and Fault Close (Close & Latch) Ratings:**

Improved interrupting and fault close ratings ensure that the network protector will withstand fault conditions and continue to protect their associated transformer.

Table 18.0-6. CM52 Ratings Comparison Table—Rating Tested at 600 Volts

Continuous Current Rating (Amperes)	Breaker Element Width—Inches (mm)	CM52		IEEE/ANSI	
		Interrupting Rating (kA)	Close & Latch Rating (kA) ①	Interrupting Rating (kA)	Close & Latch Rating (kA) ①
800	17.00 (431.8)	42	35	30	25
1200	17.00 (431.8)	42	35	30	25
1600/1875	17.00 (431.8)	42	35	30	25
2000	17.00 (431.8)	42	35	35	35
2500/2825	22.00 (558.8)	65	45	60	40
3000	22.00 (558.8)	65	45	60	40
3500	35.00 (889.0)	85	65	60	40
4500	35.00 (889.0)	85	65	60	40

① Close & Latch ratings apply only to spring close and stored energy mechanisms.

6. **Four Breaker Element Drawout Positions:**

- Connected**—Fully connected to primary and secondary connections. The door may be open or closed in this position.
- Test**—Primary clusters are disconnected, secondary wiring disconnects are made. Testing can be performed on the unit at this point without disturbing the power connections. The door may also be opened or closed in this position.
- Disconnected**—Primary clusters are disconnected, secondary disconnects are open. The door must be open in this position.
- Removable position**—Breaker element can be removed from its rails. The door must be open with the breaker element in this position.

7. **Standardized Modular Components:**

The motor, shunt trip, spring release coil, arc chutes, IDM, auxiliary switches and multi-ratio CTs are easily removable, and main components are standard across different ratings. This allows reduced part inventories and reduced training for shop and field crews.

8. **Low Maintenance:** The breaker has no adjustments required over the life of the unit and fewer replacement parts than traditional units. A built-in wear gauge shows the acceptable limit of contact wear, making the breaker condition easier to identify for service periods.



Easy Inspection

9. **Sealed Motor Gear Box:** Charges closing spring in less than 1-1/2 seconds.

10. **Indicating Diagnostic Module (IDM):** Replaces the traditional Motor Close Relay and adjustable resistor, and offers diagnostic indicators on available control voltage for the motor, spring release and “trip actuator.”

11. **Front-Mounted Test Points:** Easy access test points located on the front of the unit make for quick test cable connections and avoid requiring the operator to reach into live voltage area.



Convenient Accessories



Test Block Access Cover



Test Block with Cover Removed

- 16. **Improved Submersible Enclosure Design:** Customer-Specified Internal or External Fuse Mounting and revised Hinging and Opening hardware for easier door opening and closing. The door has greater than 90° opening capability.

Options

Arc Flash



VaultGard™ Arcflash Reduction Maintenance System™ Indicating Diagnostic Module

- 12. **Universal Wired Breaker:** Breakers are wired all the same regardless of system voltage. Breakers can be interchanged between 216V grids and 480V spots without modifications. Multi-Tap settings for current transformers make changing amperes easy for maximum flexibility and inventory reduction.
- 13. **Retrofit Adapter Frames and Bus Adapters:** Allows replacing of most older GE and Westinghouse breakers in existing enclosures.
- 14. **Color Coded Teflon® Wire:**
Red = Close Circuit
Green = Open Circuit
White = All Other
Yellow = Normally Open
Blue = Normally Closed
Black = Common
- 15. **Sixty (60) Point Secondary Contact:** Allows quick wiring for additional contacts, relays and other devices in the breaker element. Connections are automatic for breaker racking in and out.

The CM52 network protector is available with the NPARMs module (Arcflash Reduction Maintenance System).

This device is internal to the network protector and can be remotely activated usually through a switch mounted at the vault entrance or through communications. This will enable the Arcflash Reduction Maintenance System device on all CM52s in a spot network. Once activated, the NPARMs places the protectors in a sensitive mode, sensing both forward and reverse current directions. This device will actuate in 3–4 ms and call for all CM52 breakers to trip if a fault is sensed on an adjacent network protector or collector bus. It has been shown that this device limits the total incident energy to less than 8 cal/cm².

Remote Racking System

The CM52 network protector is also available with an integral remote racking system. The system remotely racks the breaker off the energized bus work while the door is still closed to the “test” position either through an external pendant or through communications.



Remote Racking System

Standards and Certifications

- Meets or exceeds the standards in IEEE C57.12.44
- The CM52 network protector is UL labeled and approved in the NEMA housing at all ratings

Seismic Qualification



Refer to **Tab 1** for information on seismic qualification for this and other Eaton products.

NPL Fuse

NPL Fuse

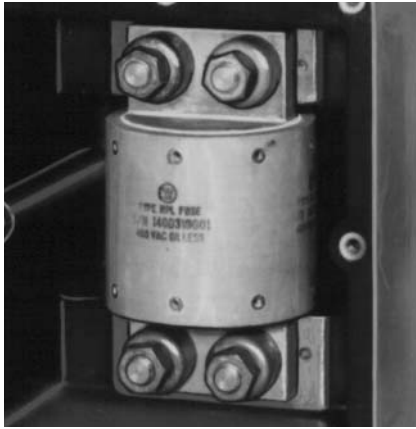

NPL Fuse

Eaton's NPL fuse has been designed as a nonexpulsion, silver-sand type fuse. It is exclusively for use on the CM52 network protector. Each end terminal is fabricated from high conductivity, impact extruded copper. High quality NEMA Grade G5 convolutely wound glass melamine tubing is permanently sealed to the terminal with RTV Silastic® to eliminate possible sand leakage or moisture entry. The terminals and tube are secured together with stainless steel, high strength, spirally wound pins. All fuses are tested on an ultra-low resistance measuring instrument capable of resolving one-hundredth of a micro-ohm and evaluated on the basis of statistical probability techniques to ensure uniformity.

Characteristics of the NPL fuse have been especially tailored for coordination with the transformer safe-heating curve and in consideration of the protector interrupting rating. This specially designed characteristic curve is less inverse than the ordinary melting characteristic of a silver-sand fuse. The curve is a function of the design of the unique, silver element used in its make-up.

The NPL fuse does not become current-limiting within the interrupting rating of the protector. The fuses have been successfully tested in its epoxy enclosure at a three-phase fault condition of 150,000A at 600V. The NPL fuse is not ampacity rated, and does not provide overcurrent protection per NEC Article 240.

Fusing a protector is necessary for three- and four-spot network transformer spot networks.

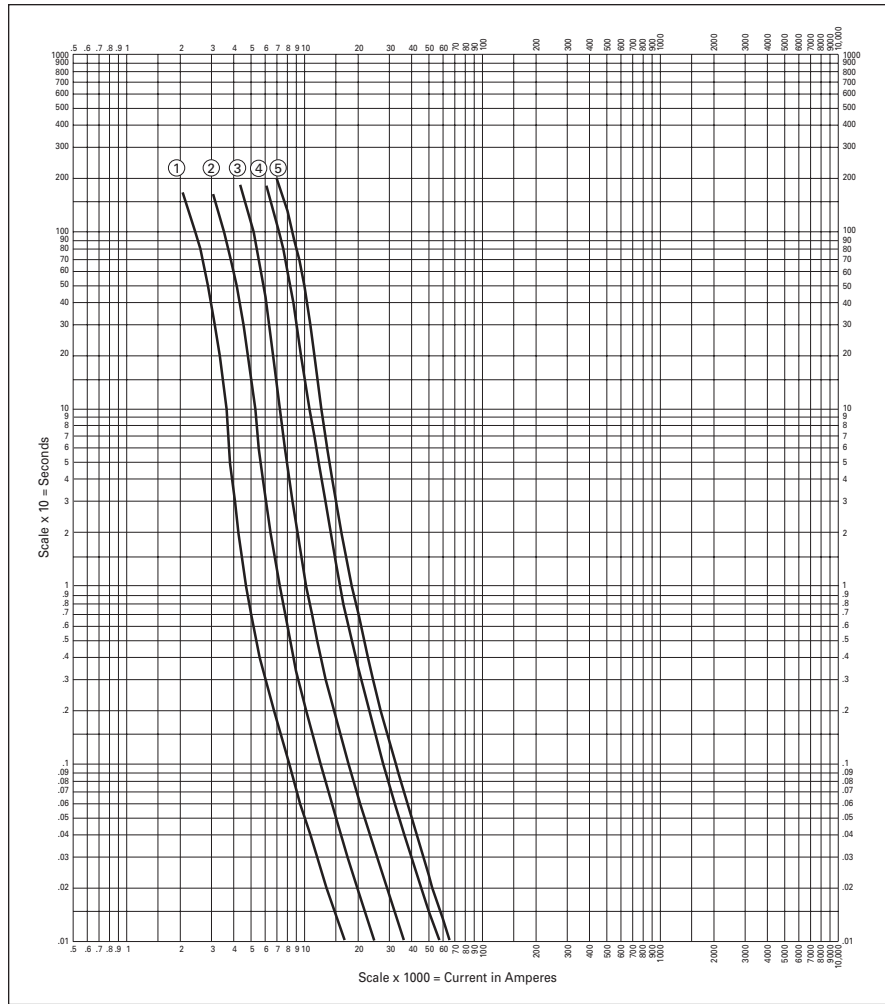

Figure 18.0-18. Average Melting Curve of NPL Fuse

Table 18.0-7. CM52 Protector Limiter Selection ①②

Protector Current Rating (A)	Limiter/Fuse Style Number	Curve Number ①
800	140D318G04	1
1200	140D318G05	2
1600–1875	140D318G01	3
2000	140D318G07	—
2500–2825	140D318G02	4
3000	140D318G06	5
3500	140D318G08	—
4000	5980C01G03	②
4500	KRPC6000	②

① These are the recommended limiters for use on three and four transformer spot network systems. The limiters are optional on two transformer systems.

② Consult Eaton for DSL fuse curve and Bussmann for KRPC fuse curved.

Type MPCV Network Protector Relay

Description

The microprocessor controlled network relays were designed to replace the Type CN-33 electromechanical master relay, the Type CNJ electromechanical phasing relay and the Type BN electromechanical desensitizing relay. The MPCV series relays use the same voltage and current inputs as do the electromechanical equivalent. They also continually monitor voltage across an open breaker and current through a closed breaker, and perform the following functions.

- The trip contact will close upon balanced fault conditions if the positive sequence power flow is out of the network
- The close contact will close if the ensuing positive sequence power will be into the network
- The trip contact will close upon the flow of reverse magnetizing current of its associated transformer

The MPCV series relay will mount on standard CM52 and existing CMD and CM-22 network protectors utilizing the present system of low voltage relay mounting studs.

MPCV Network Relay
Exclusive Features

The MPCV relay is the only sequenced-based network relay in the market. The MPCV relay calculates the fundamental frequency positive sequence voltage and current phasors to account mathematically for any power system voltage unbalances. Essentially, the MPCV relay extracts the fundamental components of the sampled voltage and current signals using discrete Fourier Transform, then the positive sequence components are then calculated. The positive sequence current phasors for each phase are compared with the reverse trip setting (RT in the setting menu) and a determination to trip is made within the relay. The sampling rate is 32 samples per power line cycle, and the algorithm requires two successive line cycles of data to initiate a trip where the positive sequence currents experienced by the MPCV relay exceed the RT settings. The MPCV has the following exclusive features:

- Gull-Wing Trip to address high X/R Network Transformers
- Anti-pump algorithm
- Protective remote close

Warning

The MPCV relays are designed to be used on network protectors which have been wired for 216Y/125V or 480Y/277V service using relay potential transformers. This relay is designed to operate at 125V (line to ground). Do not attempt to apply this relay on any other system voltage or configuration.



MPCV Relay (Front View) for CM52 Protectors

Failure to follow these instructions could result in severe personal injury, death, and/or product or property damage.

Functional Characteristics

All measurements in the relay are made as net voltages and currents, computed as the positive sequence voltage and current (represented as $V1X$ or $I1$) and the negative sequence voltage and current (represented as $V2X$ or $I2$). The network positive and negative voltages sequence are denoted $V1N$ and $V2N$ respectively. The other important voltage is the phasing voltage, which is the difference between the transformer and network voltages, whose sequence components are denoted $V1P$ and $V2P$.

The $V1N$ is defined as the reference phasor for all phase measurements, and the nominal phase-to-neutral voltage (1 P.U.) is defined as 125 Vac rms. From this, the basic functional characteristics are graphically depicted in Figures 18.0-19 through 18.0-22.

Trip Function

Figure 18.0-19 diagrams the current-induced trip characteristics. The positive sequence current $I1$ is multiplied by the cosine of the angle of its phasor related to $V1N$. If the resulting sign is negative, then reverse power flow is indicated. The trip level ($11\cos\theta$) for this can be adjusted from 0.05 to 5 percent of rated current. The cosine multiplication operation results in the straight line which is perpendicular to the phasor.

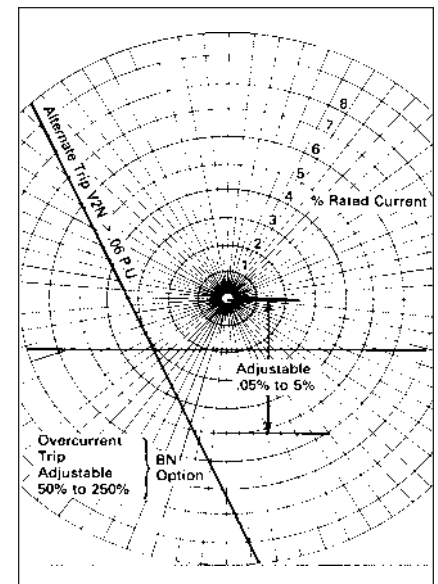

Figure 18.0-19. Trip Characteristics

In a different fault condition, the negative sequence network voltage $V2N$ will exceed 0.06 P.U., in which case the trip curve is rotated 60° clockwise direction to the alternate trip curve shown, with the same trip level as set before (0.05 to 5 percent). In either case, the trip is called for after 50 mS, or three line cycles, in a 60 Hz system, of a fault condition.

The BN function can be initialized to modify the characteristics and timing of the reverse-current trip conditions. This adds to the basic detection requirements that the true rms value of the reverse current exceeds some settable threshold between 50% and 250% of the protector CT rating. When the magnitude of the reverse current is less than the settable threshold, a trip will occur if the condition exists for an adjustable time period of 0 to 5 minutes. The BN function is standard on all MPCV relays.

Type MPCV Network Protector Relay

**Special Trip Characteristic—
“Gull-Wing” Trip**

For some applications, the straight-line trip curve is not the optimum performance setting to use. If the transformers have high X/R ratios, then the straight-line trip does not perform as well as the enhanced “Gull-Wing” trip characteristic, a feature that has been in the MPCV relay since 2003. Technically, the following circumstances benefit from having the enhanced “Gull-Wing” trip feature:

- Under a three-phase fault with the X/R ratio higher than 11.4, the voltage to current angle is less than 95 degrees
- Double line-ground faults on the primary of a delta-wye transformer with blown protector fuse on one phase
- Single line-ground fault on the primary of grounded wye-grounded wye transformer with blown protector fuse on one phase

Close Characteristics

Figure 18.0-23 also diagrams the voltage regions for close, float and trip operation when the protector is open. Under extreme conditions when the protector is open, a trip is called for to prevent a dangerous manual close operation. With the protector open and the network and transformer voltages normal and balanced, positive sequence phasing voltage (V1P) is measured. If V1P is in the close region, the relay makes its close contact. If V1P is not in the close region, but is less than 0.06 P.U., then the float is called for, as this voltage difference is not deemed dangerous regardless of the phase relationships, and manual close of the protector would not exceed the breaker capacity. If V1P is greater than 0.06 P.U. and does not lie in the close region, then trip is called for to prevent manual closing. The relay also calls for trip under all rolled and crossed phase conditions, even when either the transformer side or the network side of the protector is de-energized.

The close contact will close only in the quadrant defined by the two lines, termed master and phasing. The phasing line, emanating from 0, defines a minimum phase angle of the phasing voltage ahead of the network voltage for closing, which is selectable at +5°, -5°, -15° or -25°. The master line sets a minimum difference between the transformer and network voltage, settable from 0.0008 to 0.02 P.U. at 0° (in phase). This line exhibits a slope of 7.5°.

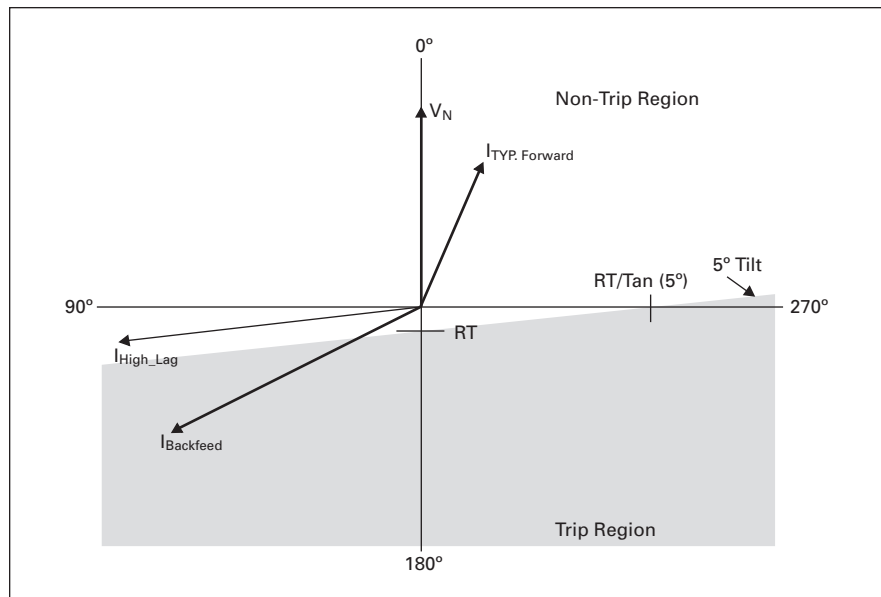

Figure 18.0-20. Traditional Relay Trip Characteristic

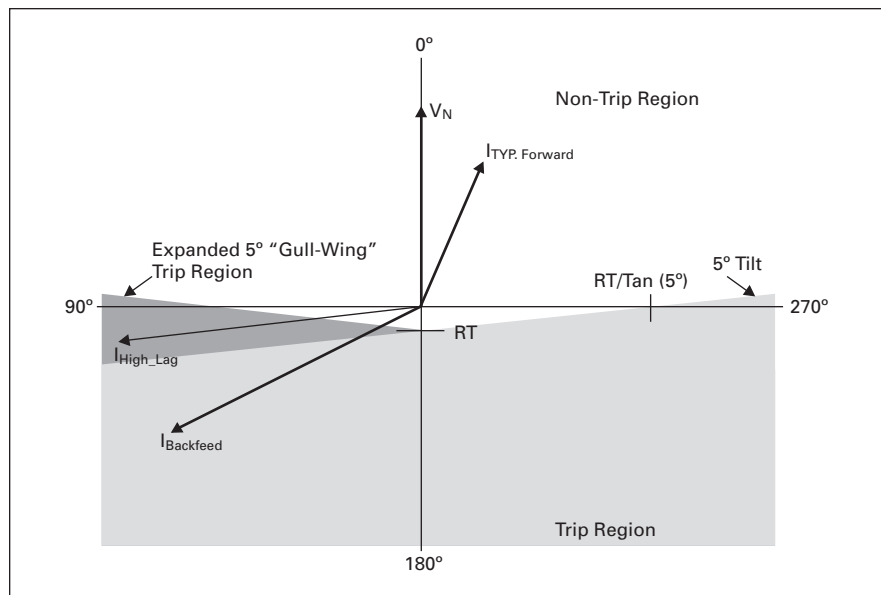

Figure 18.0-21. Enhanced “Gull-Wing” Trip Characteristic

**Protective Remote Close (PRC)
Feature**

This feature helps address problems with very lightly loaded network protectors. If a protector is opened and the system is very lightly loaded, the users had to manually close the protector that had opened. The MPCV can be sent a PRC communications close command via any Eaton communication

option available. The PRC command is not an unqualified close, rather the MPCV relay relaxes its master line setting to 75 mV and the command closes the protector provided the phase voltage angle is in the widen close window. After closure, the MPCV relay automatically readjusts the master line setting back to the original master line setting configured in the relay.

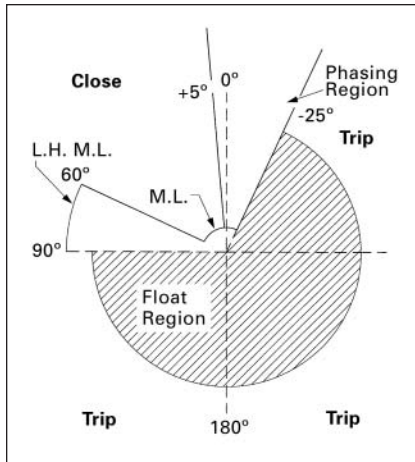

Figure 18.0-22. Circular Closing Curve

Note: If the phases are crossed on both the transformer and the network side, V_{2P} could be very close to or equal to zero, but the trip contact will close as V_{1N} is less than 0.1 P.U. and V_{1P} is less than 0.8 P.U.

The other closing curve characteristic option available is the circular line closing curve which maintains the same value of phasing volts from the -25° to $+90^\circ$ quadrants (refer to Figure 18.0-22). The circular closing curve permits the network protector to close at lower loads while ensuring the watt flow is into the network.

Any close conditions must exist for 500 ms before the close contact will close.

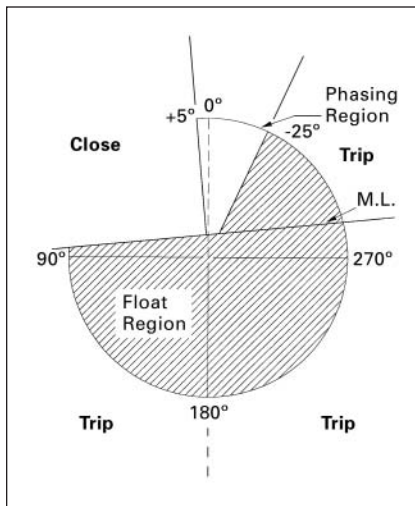

Figure 18.0-23. Closing Characteristics—Straight Closing

If the network side is de-energized, and the transformer side is energized, the close contact will close, if V_{1N} is less than 0.1 P.U., and V_{2N} is less than 0.06 P.U., and V_{1P} exceeds 0.8 P.U. Note that, as stated before, if V_{2P}

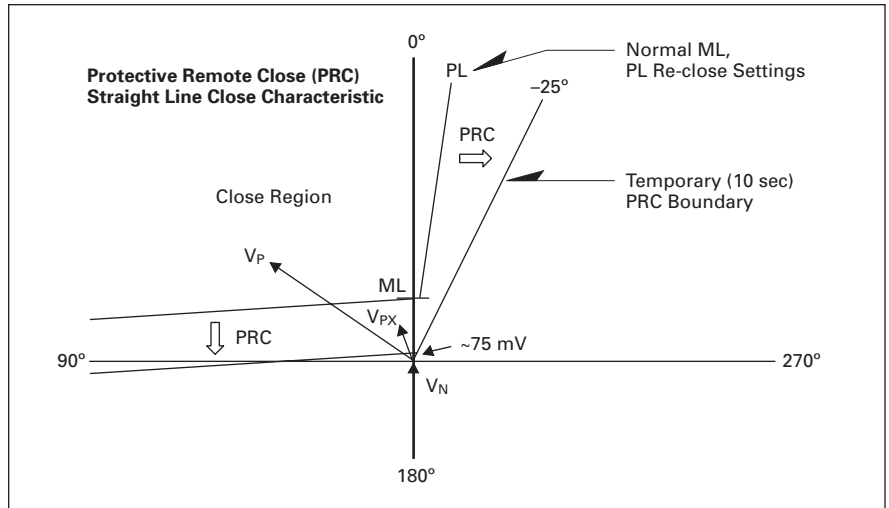

Figure 18.0-24. PRC—Straight Line Close

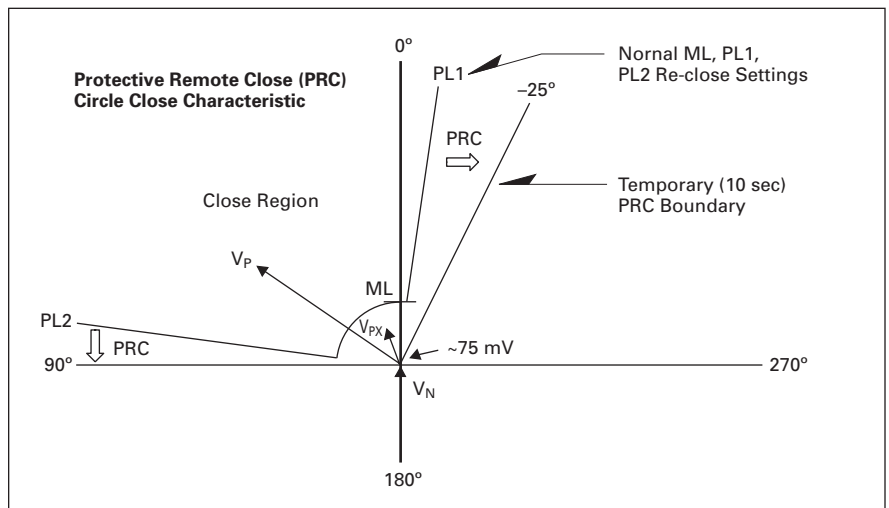

Figure 18.0-25. PRC—Circle Close

exceeds 0.2 P.U., then the trip contact will close, indicating crossed phases on either the transformer side or the network side.

Settings

All settings can be altered through a digital programming pendant which plugs into the unit while mounted on the network protector breaker. When not in use, the pendant may be stored separate from any network protector location, most conveniently with the network protector test kit. While the pendant is plugged in, actual trip and close operations will be inhibited and the amber float light will flash. The pendant has a display for the readout of the set points and a keyboard to set them.

Factory default settings are programmed into each MPCV network relay, however,

each project and protector application represents different voltage and loading conditions, which can require adjustment of the default settings to other appropriate values. Experienced service technicians must be used when commissioning protectors, and proper tools such as protector test sets and programming pendants must be used to start up protectors and maintain the units.

Relay settings can also be implemented via PowerNet software, which allows for the full use of the communication features of the MPCV network relay as described on the following pages. Non-Eaton communication protocols may be able to interface with a sub-network of MPCV relays through a data concentrator and an independently written and supplied driver.

MPCV Network Relay Communications

Control and Monitoring Capabilities from MPCV Network Relays

Proven PowerNet™ and Power Xpert® software, developed by Eaton, provides an operator with the capability to control network protectors from a personal computer... while simultaneously monitoring power quality and operating conditions, providing this information in real time.

PowerNet software is a user-friendly, Microsoft® Windows®-based program that allows the operator to point and click through the screens. Standard software screens are appropriate for most applications but can be customized to meet your individual requirements.

Power Xpert is a Web-based information gathering system that uses only Ethernet browsers and IP addresses to display data. No custom or proprietary vendor software is required.

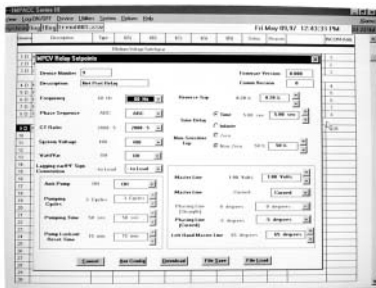

Sample Set Point Screen

Monitoring

PowerNet and Power Xpert provides energy management, operations and equipment status information, and offers the operator these capabilities:

- **Real-time information.** The operator commands an inquiry to each MPCV Relay on the system which logs current, voltage, power (watts, vars and VA), energy, frequency, demand, power factor, and total harmonic distortion (THD). This information is displayed on a single screen
Also displayed on this screen is network protector inside air temperature. Additionally, from the same screen, the operator can select to view the last trip waveform or review the MPCV Relay set points
- **Data printout.** Real-time information from all MPCV Relays on any one feeder can be printed out to provide a near instantaneous load flow of the entire feeder
- **Internal environment of the network protector enclosure.** Water inside the network housing and upper copper bus temperatures. Breaker status (open/closed)
- **Vault environment.** Transformer top oil temperature, water in the network vault, fire alarm, and network enclosure pressure



Sample Monitoring Screen

Control

PowerNet provides multiple network protectors controlled from a remote location and allows the following capabilities:

- **Close or trip the breaker relay contacts.** If the operator chooses to have the breaker's relay trip contact "make," the breaker opening can be viewed on-screen and listed currents will go to zero. A designed-in safety feature prevents the network protector from being closed while the MPCV Relay trip contact is "made" until the relay trip response is removed
- **Relay set points.** The operator can review or change the operational set points without using the hand-held controlling pendant. Password protected security helps prevent accidental or improper usage

Alarming

Eaton software provides the operator with these capabilities:

- Receive an alarm in real time. When an established parameter of a monitoring function is reached or exceeded, an alarm condition is displayed immediately on the PC screen, enabling the operator to:
 - Identify the vault or feeder in question
 - Determine what alarm has been triggered and at what location
- Power Xpert is a Web-based approach to communications without proprietary vendor software
 - For more information, visit the URLs below:
 - www.eaton.com/powerxpert
 - www.eaton.com/pxm
 - www.eaton.com/pxg
 - www.eaton.com/pxs
 - www.eaton.com/pxr

Other Communication Protocols

Eaton has introduced two new communications options for the MPCV relay, those being the VaultGard™, and the DNP MINT.

VaultGard



VaultGard

This device server can display up to 32 MPCV relays on one screen. The protocol is Ethernet and/or DNP 3.0. Devices can be connected in various communication configurations, such as hardwired LAN or wireless, including short-range wireless from module (100m), cellular modem and hot spot zone connect ability.

The server is simple to connect and requires no software, only Internet Explorer. The system displays real time voltage and current readings, PF, watts, temperature, open/close status, relay set points and MPCV relay control-remote open and block open, protective remote close (PRC). The device can log up to 32 MPCV relay data and provide MPCV reason code outputs.

- No software needed!—wireless Wi-Fi or hardware Ethernet connection
- Object trending
- Operations counter
- Wireless control and calibration color coded alarms
- E-mail notification (with cellular, hot spot or ethernet connection configuration)
- Automatically discovers connected MPCVs
- Reason code display
- No new relay to purchase
- 128 bit security
- Data logging
- DNP 3.0, up and down link
- DNP 3.0 RS-485
- DNP 3.0 over Ethernet

DNP MINT Translator



DNP MINT Translator

The DNP MINT allows connection of up to 16 devices, including MPCV relays, DT810 and DT910 trip units, DT OPTIM, DT 520MC, DT1150, DT3000, DTMV, DT3200, DP-4000, DIM digital input module, and addressable relays. The output is DNP3.0 in RS-485.

The DNP MINT can be configured either hardwired, fiber optic, 900 MHz radio, or cellular.

- Up to 16 MPCVs or other devices can be connected to one module
- RS-485 uplink allows networking multiple DNP MINTs
- Toggle switch controlled configuration mode
- Class 0 polling and Class 1, 2, 3 events supported
- Direct operate or select and operate remote control
- Can be hardwired or wirelessly viewed
- Simple twisted pair to MPCVs can be run up to 10,000 feet

Communications Configurations

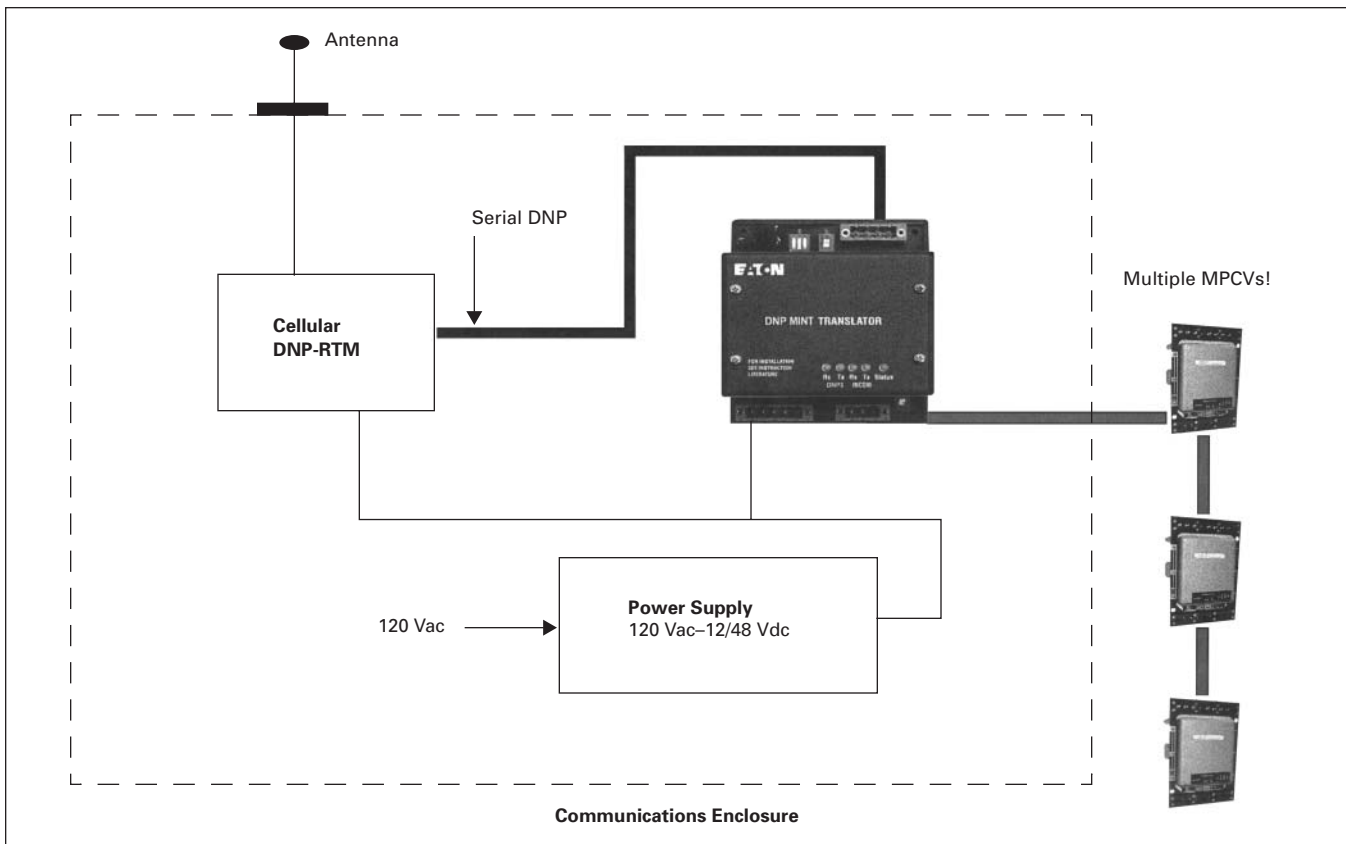

Figure 18.0-26. Configuration #1—Cellular with DNP

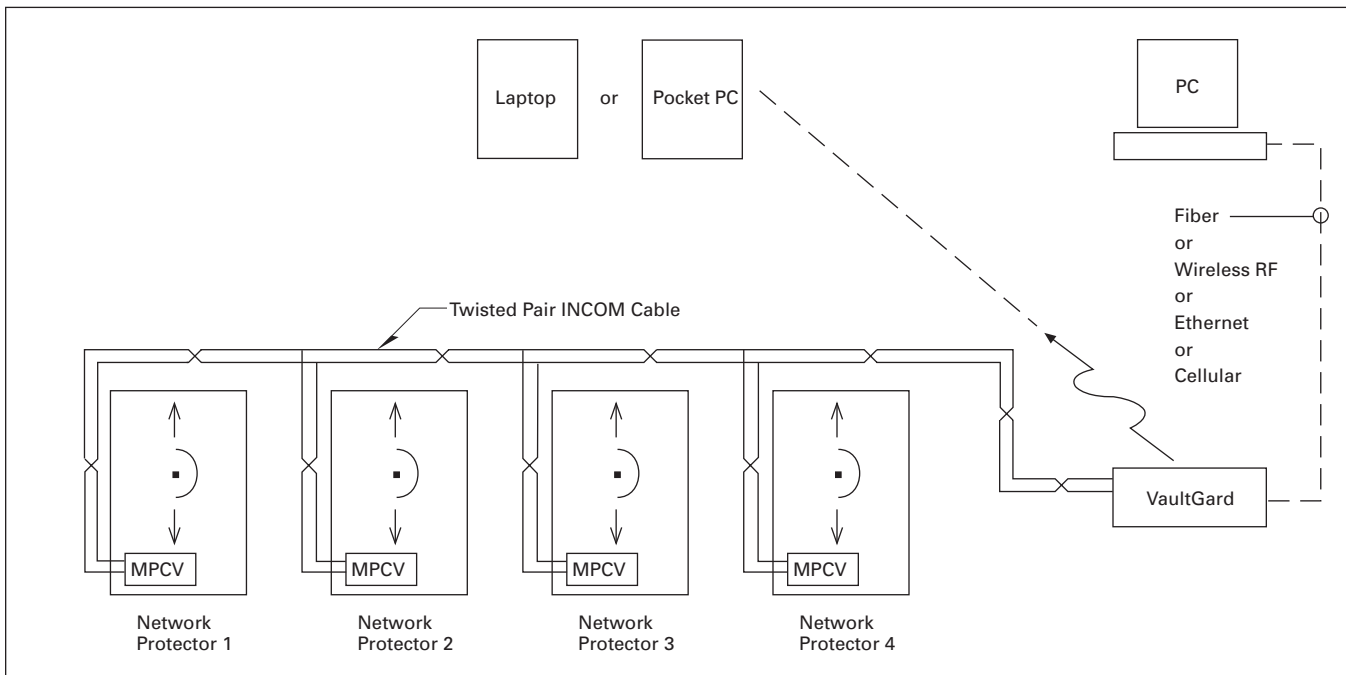

Figure 18.0-27. Configuration #2—Wireless Sites/Digital Communication Links

CM52 Protector Schematic

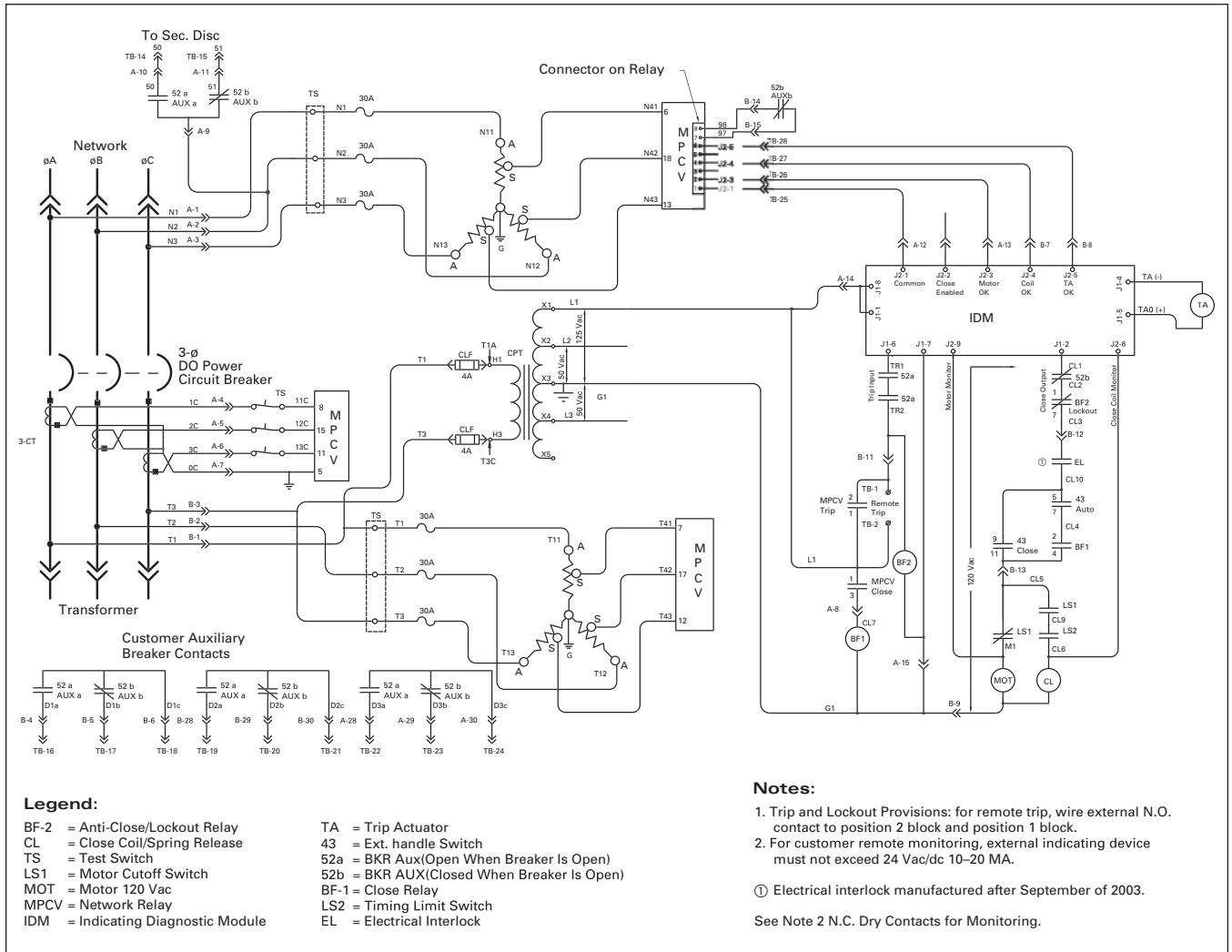

Figure 18.0-28. Typical Schematic Diagram—CM52 Network Protector 480V/277V

Network Disconnect Cabinet

Network Disconnect Cabinet



Typical Network Disconnect—
Neutral Connection Visible

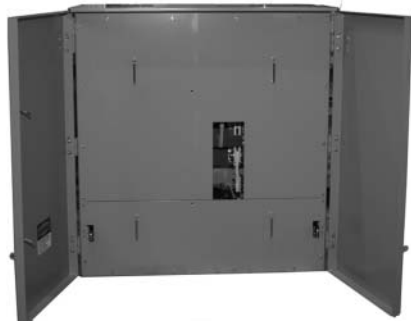

Typical Network Disconnect—
with Doors Open

Network disconnects are an important safety item for spot network systems. Many forms of disconnect are available, including downstream main breakers and non-loadbreak disconnects at the top of the network protector. This page describes the non-loadbreak product.

Network disconnect means on the load side of each protector is necessary to allow safe access to the protector and protector fuses in the circuit. These fuses are on the load side of the protector and are still energized from the downstream network when a given protector is opened. Safe access to the fuses requires some form of network disconnect means, as outlined above.

Eaton recommends the use of a network disconnect means for each protector on all spot network systems. The choice is up to the owner or designer based upon costs and available space. The non-loadbreak product from Eaton is a hook-stick, gang operated mechanism. The non-loadbreak design allows for easier Open-Close operations from the floor at the front of the unit compared to loadbreak designs. The protector, not

the disconnect, is always used to break and make load current. The mechanism is behind electrically interlocked cabinet doors, which when opened, trips open the protector. Common ratings are 800–4000A, 600 Vac and below.

The cabinet designs are NEMA 1 indoor only. The protector has a flange at the top which allows for the mounting of the disconnect at the top of each respective protector. In many cases, it is possible to locate current transformers within the network disconnect cabinet to provide for forward 50/51 protection (relays mounted remotely) on the network circuits. These relays serve to monitor the circuit and trip the network protector when faults occur within the power circuit feeding the downstream spot network switchgear.

In some cases, it is possible to locate the protector fuses within the cabinet.

Eaton designs, manufactures and tests the non-loadbreak disconnects at the same factory that makes the network protectors, and the plant is ISO 9000 certified. Product electrical and dimensional coordination is ensured between the protectors and network disconnects with Eaton. Due to the mounting location, the network disconnects are seated at high distances from the floor and sufficient vertical space must exist in the electrical room to accommodate the non-loadbreak product.

The load conductor cables or busway are connected at the top of each network disconnect. The drawings detailed on this page depict a busway flange and connection. When busway is used, only two flange orientations are preferred and those align the busway phase conductors with the A, B, C left to right orientation of the protector phase conductors.

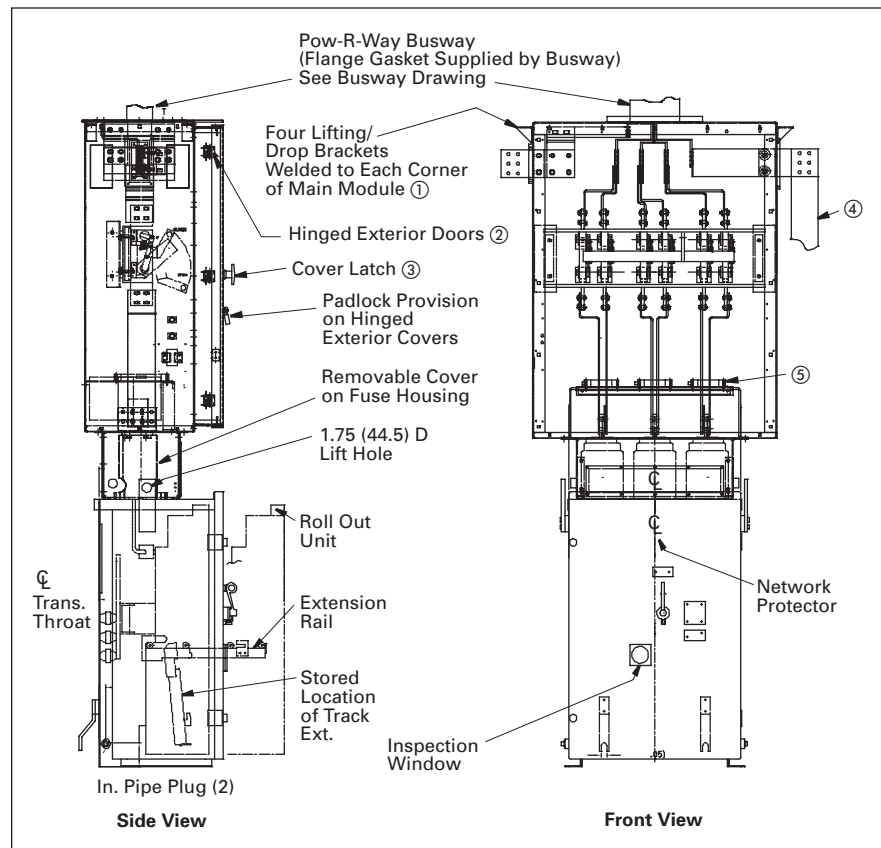

Figure 18.0-29. Typical 3000A Non-Loadbreak Disconnect Mounted on a Network Protector

- ① 0.50 All-thread rod must be used for hanging as permanent support from overhead.
- ② Disconnect enclosure cabinet: interior and exterior surfaces receive "ANSI-61 Cationic Epoxy Electrocoat" grey finish over phosphatized 12 gauge steel. The interior of main module is then finished gloss white.
- ③ Three-point cover latching mechanism between the two hinged front covers.
- ④ Dimensions for the neutral connection from disconnect cabinet to X/O on transformer must be supplied by contractor.
- ⑤ Current transformers mounted inside cubicle. CT ratio and class per customer's specifications.

Network Transition Box

Network Transition Box

Network transition boxes are used at the top of protectors when the network disconnect takes a form other than the non-loadbreak disconnect explained on the previous page. Two other forms of disconnect are available, including downstream main breakers and downstream fused drawout fuse trucks. This page describes the transition box product.

Network disconnect means on the load side of each protector is necessary to allow safe access to the protector and protector fuses in the circuit. These fuses are on the load side of the protector and are still energized from the downstream network when a given protector is opened. Safe access to the fuses requires some form of network disconnect means, as outlined above.

Eaton recommends the use of a network disconnect means for each protector on all spot network systems. The decision to use a main breaker or drawout fuse truck implies that the protector circuit does not use the non-loadbreak disconnect, perhaps due to the lack of space at the top of the protector. The downstream disconnect is usually key interlocked with the network protector, especially when the disconnect is the drawout fuse truck. The area at the top of the protector becomes a transition area to connect to cables or busway. Common ratings for transition boxes are 800–4000A, 600 Vac and below.

The transition box designs are NEMA 1 indoor and NEMA 3R outdoor only. The protector has a flange at the top which allows for the mounting of the transition box at the top of each respective protector. In many cases it is possible to locate current transformers within the network transition to provide for forward 50/51 protection (relays mounted remotely) on the network circuits. These relays serve to monitor the circuit and trip the network protector when faults occur within the power circuit feeding the downstream spot network switchgear.

Eaton designs, manufactures and tests transition boxes the same factory that makes the network protectors, and the plant is ISO 9000 certified. Product electrical and dimensional coordination is ensured between the protectors and transition boxes with Eaton.

The load conductor cables or busway are connected at the top of each transition box. The drawings detailed on this page depict a busway flange and connection. When busway is used, several flange orientations are preferred and those align the busway phase conductors with the A, B, C left to right orientation of the protector phase conductors.

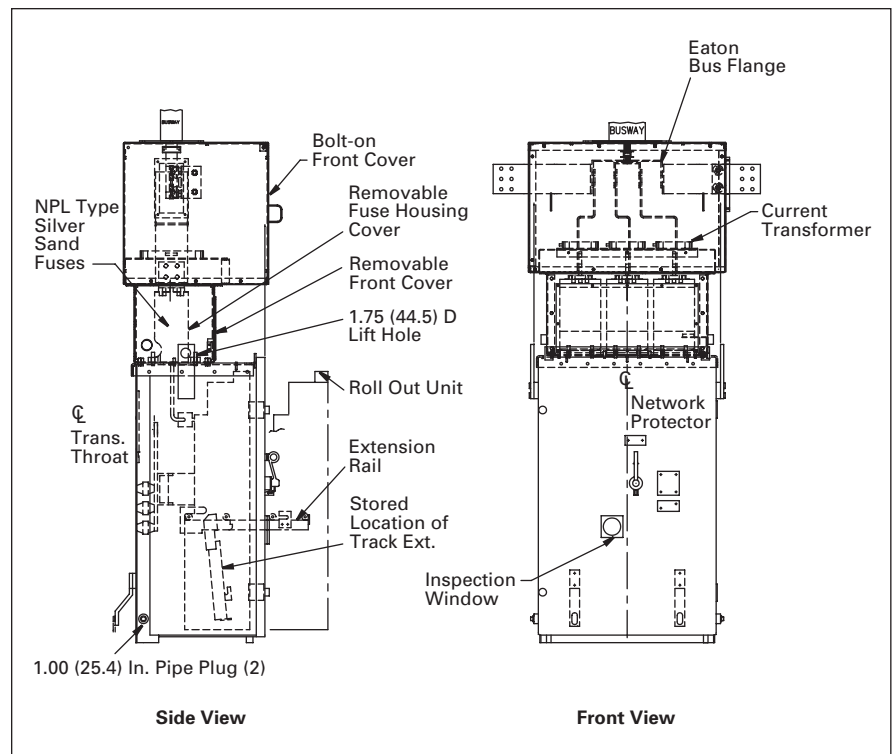

Figure 18.0-30. Typical 1875A Network Transition Box Mounted on a Network Protector

Spot Network Equipment Selector Guide

Figure 18.0-31 illustrates the general configuration of the network equipment for Tables 18.0-9 through 18.0-12 equipment values. For three-unit spot networks, the fourth transformer/protector pair and load L4 bus and load do not exist. For 2-unit spot networks, the third and fourth transformer/protector pairs and load L3 and L4 buses and loads do not exist. Tables 18.0-9 through 18.0-12 are developed for systems anticipating only one primary feeder outage, and secondary voltage is 480 wye or 208 wye respectively.

Table 18.0-8. CM52 Protector Features

Features	CM52 ①
Continuous current ratings in amperes	800–4500A
Operating mechanism	Spring close
Close and latch rating available	Yes
Mechanism withdrawal	Drawout
Mechanical life (no. ops)	10,000
Withdrawn construction	Deadfront
Protector fuse type	Silver- sand NPL type
Fuse location	External ②
Protector trip device	Shunt trip
Dielectric test passed	2200V
UL label	Yes

① Strongly recommended for spot network applications. Used optional pre-charge energy mechanism on two transformer spot networks.

② NPL fuses can be mounted in epoxy enclosures or network disconnect cabinets.

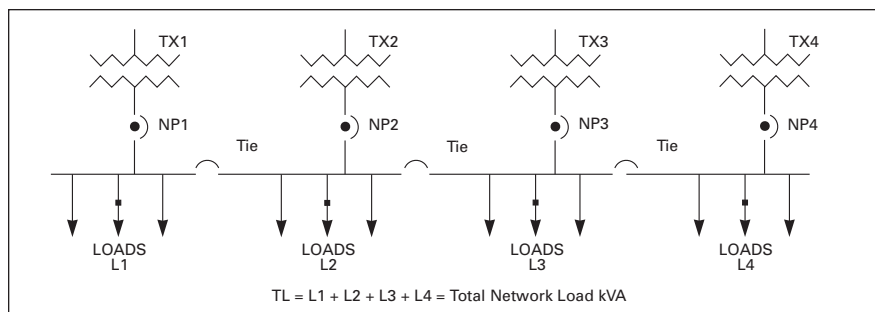

Figure 18.0-31. Spot Network Configurations

Table 18.0-9. Spot Network Equipment Ratings for Liquid Transformers—480V Secondaries Liquid Transformers (Including Oil and Silicone) OA 55°C Rise with 138% Short Time Capacity (Up to 24 Hours for Probable Sacrifice of 1% Life)

Total Network TX kVA Nominal	TL = Load kVA (Maximum for One PRI Outage)	TX = Network TX kVA (55°C Liquid)	NP = Protector Ampacity at 480V	LV Switchgear Tie Breaker Frame/ Trip Amperes
------------------------------	--	-----------------------------------	---------------------------------	---

Two-Unit Spot Network TL = L1+L2 and L3 = L4 = 0—TX3 and TX4 are Absent

1000	690	500	1200	800/800AT
1500	1035	750	1600	1600/1200AT
2000	1380	1000	1875	1600/1600AT
3000	2070	1500	2500	3200/2200AT
4000	2760	2000	3500	4000/3200AT
5000	3450	2500	4500	4000/4000AT

Three-Unit Spot Network TL = L1+L2+L3 and L4 = 0—TX4 is Absent

1500	1380	500	1200	800/800AT
2250	2070	750	1600	1600/1200AT
3000	2760	1000	1875	1600/1600AT
4500	4140	1500	2500	3200/2200AT
6000	5520	2000	3500	4000/3200AT
7500	6900	2500	4500	4000/4000AT

Four-Unit Spot Network TL = L1+L2+L3+L4—All TXs are Present

2000	2070	500	1200	800/800AT
3000	3105	750	1600	1600/1200AT
4000	4140	1000	1875	1600/1600AT
6000	6210	1500	2500	3200/2200AT
8000	8280	2000	3500	4000/3200AT
10000	10350	2500	4500	4000/4000AT

Table 18.0-10. Spot Network Equipment Ratings for Dry Transformers—480V Secondaries Dry-Type Transformers (Including VPI, VPE and Cast Coil) AA/FA 80°C Rise with 150% Overload Capacity (Continuous when Fan Cooling is Active and Ambient is 30°C)

Total Network TX kVA Nominal	TL = Load kVA (Maximum for One PRI Outage)	TX = Network TX kVA (80°C Dry)	NP = Protector Ampacity at 480V	LV Switchgear Tie Breaker Frame/ Trip Amperes
------------------------------	--	--------------------------------	---------------------------------	---

Two-Unit Spot Network TL = L1+L2 and L3 = L4 = 0—TX3 and TX4 are Absent

1000	750	500	1200	1600/1000AT
1500	1125	750	1600	1600/1400AT
2000	1500	1000	1875	2000/1600AT
3000	2250	1500	2825	3200/2600AT
4000	3000	2000	3500	4000/3200AT
5000	3750	2500	4500	4000/4000AT

Three-Unit Spot Network TL = L1+L2+L3 and L4 = 0—TX4 is Absent

1500	1500	500	1200	1600/1000AT
2250	2250	750	1600	1600/1400AT
3000	3000	1000	1875	2000/1600AT
4500	4500	1500	2500	3200/2600AT
6000	6000	2000	3500	4000/3200AT
7500	7500	2500	4500	4000/4000AT

Four-Unit Spot Network TL = L1+L2+L3+L4—All TXs are Present

2000	2250	500	1200	1600/1000AT
3000	3375	750	1600	1600/1400AT
4000	4500	1000	1875	2000/1600AT
6000	6750	1500	2500	3200/2600AT
8000	9000	2000	3500	4000/3200AT
10000	11250	2500	4500	4000/4000AT

Spot Network Equipment Selector Guide

Table 18.0-11. Spot Network Equipment Ratings for Liquid Transformers—216Y or 208Y Secondaries Liquid Transformers (Including Oil and Silicone) OA 55°C Rise with 138% Short Time Capacity (Up to 24 Hours for Probable Sacrifice of 1% Life)

Total Network TX kVA Nominal	TL = Load kVA (Maximum for One PRI Outage)	TX = Network TX kVA (55°C Liquid)	NP = Protector Ampacity at 216 or 208V	LV Switchgear Tie Breaker Frame/Trip Amperes
Two-Unit Spot Network TL = L1+L2 and L3 = L4 = 0—TX3 and TX4 are Absent				
1000	690	500	2000	2000/1900AT
1500	1035	750	3000	3200/2800AT
2000	1380	1000	4500	4000/4000AT
3000	2070	1500	①	5000/5000AT
4000	2760	2000	N/A	N/A
5000	3450	2500	N/A	N/A
Three-Unit Spot Network TL = L1+L2+L3 and L4 = 0—TX4 is Absent				
1500	1380	500	2000	2000/1900AT
2250	2070	750	3000	3200/2800AT
3000	2760	1000	4500	4000/4000AT
4500	4140	1500	①	5000/5000AT
6000	5520	2000	N/A	N/A
7500	6900	2500	N/A	N/A
Four-Unit Spot Network TL = L1+L2+L3+L4—All TXs are Present				
2000	2070	500	2000	2000/1900AT
3000	3105	750	3000	3200/2800AT
4000	4140	1000	4500	4000/4000AT
6000	6210	1500	①	5000/5000AT
8000	8280	2000	N/A	N/A
10000	10350	2500	N/A	N/A

① For the listed table Total Load values (TL) protector ratings are not available. However, protector ratings are available through 5000A, which will support reduced TL (Total Load) values of 1871 kVA, 3742 kVA and 5613 kVA for 2-, 3-, and 4-unit spot networks, respectively at 216Y volt secondary (4% less load values are supported if 208Y is the system voltage).

Note: NA indicates that spot networks are not available.

Table 18.0-12. Spot Network Equipment Ratings for Dry Transformers—216Y or 208Y Secondaries Dry Transformers (Including VPI, VPE and Cast Coil) AA/FA 80°C Rise with 150% Overload Capacity (Continuous when Fan Cooling is Active and Ambient is 30°C)

Total Network TX kVA Nominal	TL = Load kVA (Maximum for One PRI Outage)	TX = Network TX kVA (80°C Dry)	NP = Protector Ampacity at 216 or 208V	LV Switchgear Tie Breaker Frame/Trip Amperes
Two-Unit Spot Network TL = L1+L2 and L3 = L4 = 0—TX3 and TX4 are Absent				
1000	750	500	2250	2000/1900AT
1500	1125	750	3500	3200/3100AT
2000	1500	1000	4500	4000/4000AT
3000	2250	1500	②	5000/5000AT
4000	3000	2000	N/A	N/A
5000	3750	2500	N/A	N/A
Three-Unit Spot Network TL = L1+L2+L3 and L4 = 0—TX4 is Absent				
1500	1500	500	2250	2000/1900AT
2250	2250	750	3500	3200/3100AT
3000	3000	1000	4500	4000/4000AT
4500	4500	1500	②	5000/5000AT
6000	6000	2000	N/A	N/A
7500	7500	2500	N/A	N/A
Four-Unit Spot Network TL = L1+L2+L3+L4—All TXs are Present				
2000	2070	500	2250	2000/1900AT
3000	3105	750	3500	3200/3100AT
4000	4140	1000	4500	4000/4000AT
6000	6210	1500	②	5000/5000AT
8000	8280	2000	N/A	N/A
10000	10350	2500	N/A	N/A

② For the listed table Total Load values (TL) protector ratings are not available. However, protector ratings are available through 5000A, which will support reduced TL (Total Load) values of 1871 kVA, 3742 kVA and 5613 kVA for 2-, 3-, and 4-unit spot networks, respectively at 216Y volt secondary (4% less load values are supported if 208Y is the system voltage).

Note: NA indicates that spot networks are not available.

Protector Application Information

Protector Application Information

Table 18.0-13. Transformer and Protector Combinations and Protector Ratings—CM52 Protectors

Network Transformer		Network Protectors			
Transformer Nameplate kVA Rating	Full Load Current rms Amperes	Continuous Current Rating rms Amperes	Protector Rating as % of Transformer Full Load Current	Interrupting Rating in rms Symmetrical Amperes ^{①②}	Close and Latch Rating in rms Symmetrical Amperes
System Voltage = 216Y/125 or 208Y/120					
225	600	800	133	42,000	35,000
300	800	1200	150	42,000	35,000
500	1333	1600	120	42,000	35,000
500	1333	1875	141	42,000	35,000
500	1333	2000	150	42,000	35,000
500	1333	2250	169	65,000	45,000
750	2000	2500	125	65,000	45,000
750	2000	2825	141	65,000	45,000
1000	2667	3000	112	65,000	45,000
1000	2667	3500	131	85,000	65,000
1000	2667	4500	169	85,000	65,000
System Voltage = 480Y/277					
500	600	800	133	42,000	35,000
750	900	1200	133	42,000	35,000
1000	1200	1600	133	42,000	35,000
1000	1200	1875	158	42,000	35,000
1000	1200	2000	167	42,000	35,000
1000	1200	2250	188	65,000	45,000
1500	1800	2500	139	65,000	45,000
1500	1800	2825	157	65,000	45,000
2000	2400	3000	125	65,000	45,000
2000	2400	3500	145	85,000	65,000
2500	3000	4500	150	85,000	65,000
2500	3000	5000	167	85,000	65,000

① The interrupting rating exceeds the available fault current from the transformer.

② The short time rating of protectors without fuses equals the interrupting rating.

Note: Use this table and its equipment ratings when designing network systems where the protectors are rated lower or higher, as a percentage of the full load amperes of the transformers, than those selected in the Tables 18.0-9 through 18.0-12. This table is also useful when selecting equipment ratings for systems that anticipate more than one single primary outage, e.g., when two outages are expected on a four-transformer spot network.

Liquid-Type Network Unit Dimensions

Dimensions

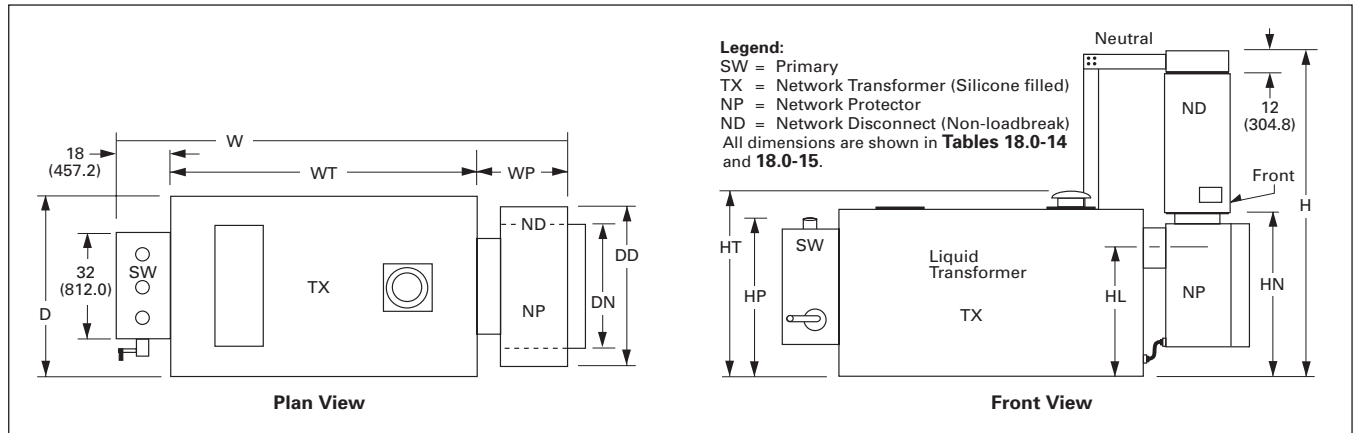

Figure 18.0-32. Liquid Network Unit Dimensions and Weights, Indoor Design

Note: Dimensions are approximate for silicone filled network transformers and are typical for the ratings indicated. Designs can be customized to fit into existing spaces in many instances, although at higher cost. Specifiers are encouraged to consult Eaton to facilitate special existing conditions.

Table 18.0-14. Liquid Network—Dimensions in Inches (mm)

Network Equipment		Dimensions—Refer to Plan and Front View Figures Above										
TX kVA	NP Amps	HT	HP	HL	HN	H	WT	WP	W	DN	DD	D
500	1200	64 (1625.6)	49 (1244.6)	40 (1016.0)	52 (1320.8)	106 (2692.4)	50 (1270.0)	34 (863.6)	102 (2590.8)	32 (812.8)	34 (863.6)	42 (1066.8)
750	1600	67 (1701.8)	50 (1270.0)	43 (1092.2)	55 (1397.0)	109 (2768.6)	53 (1346.2)	34 (863.6)	105 (2667.0)	32 (812.8)	34 (863.6)	45 (1143.0)
1000	1875	77 (1955.8)	54 (1371.6)	54 (1371.6)	66 (1676.4)	120 (3048.0)	56 (1422.4)	34 (863.6)	108 (2743.2)	32 (812.8)	34 (863.6)	48 (1219.2)
1500	2500	83 (2108.2)	57 (1447.8)	55 (1397.0)	69 (1752.6)	123 (3124.2)	62 (1574.8)	36 (914.4)	116 (2946.4)	38 (965.2)	34 (863.6)	55 (1397.0)
2000	3500	90 (2286.0)	61 (1549.4)	65 (1651.0)	74 (1879.6)	②	66 (1676.4)	38 (965.2)	122 (3098.8)	38 (965.2)	②	63 (1600.2)
2500	4500	93 (2362.2)	63 (1600.2)	67 (1701.8)	90 (2286.0)	②	68 (1727.2)	42 (1066.8)	128 (3251.2)	48 (1219.2)	②	68 (1727.2)

① Protector selected at 480V per Table 18.0-9 recommendations.

② Consult Eaton for network disconnect information. If disconnect is remote from this location, then the transition box at top of protector is 30.00–36.00 inches (762.0–914.4 mm) above protector flange.

Table 18.0-15. Liquid Network—Weights in Lb (kg)

Network Equipment		Weights in Lbs (kg)			Liquid Gallons (Liters)
TX kVA	NP Amps	Network TX ③	Protector NP	Network Disconnect	Network TX ④
500	1200	7800 (3541)	850 (386)	250 (114)	220 (833)
750	1600	10,600 (4812)	850 (386)	300 (136)	250 (946)
1000	1875	11,400 (5176)	850 (386)	350 (159)	320 (1211)
1500	2500	16,100 (7309)	1200 (545)	400 (182)	500 (1893)
2000	3500	21,000 (9534)	1450 (658)	⑤	600 (2271)
2500	4500	24,000 (10,896)	1500 (681)	⑤	700 (2650)

③ Weights for transformers include the fluid weight.

④ The number of gallons of liquid includes the fluid inside the primary switch.

⑤ Consult Eaton for network disconnect information. If disconnect is remote from this location, then the transition box at top of protector is 30.00–36.00 inches (762.0–914.4 mm) above protector flange.

Dry-Type Network Unit Dimensions

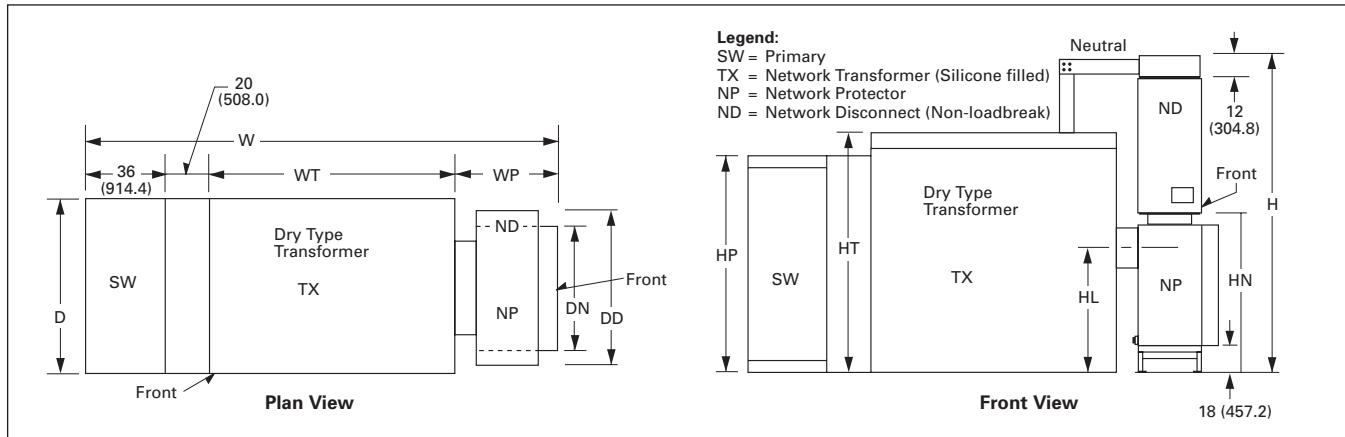

Figure 18.0-33. Dry-Type Network Unit Dimensions and Weights, Indoor Design

Note: Dimensions and weights are for standard VPI or VPE Dry-Type designs, 80°C rise with fans with 150% continuous overload capacity and aluminum windings. Copper windings add more weight. Primary voltage is 15 kV, 95 kV BIL insulation.

Table 18.0-16. Dry-Type Network—Dimensions in Inches (mm)

Network Equipment		Dimensions—Refer to Plan and Front View Figures Above										
TX kVA	NP ① Amps	HT	HP	HL	HN	H	WT	WP	W ②	DN	DD	D
500	1200	90 (2286.0)	90 (2286.0)	56 (1422.4)	69 (1752.6)	123 (3124.2)	90 (2286.0)	34 (863.6)	180 (4572.0)	32 (812.8)	34 (863.6)	66 (1676.4)
750	1600	90 (2286.0)	90 (2286.0)	56 (1422.4)	69 (1752.6)	123 (3124.2)	102 (2590.8)	34 (863.6)	192 (4876.0)	32 (812.8)	34 (863.6)	66 (1676.4)
1000	1875	102 (2590.8)	90 (2286.0)	56 (1422.4)	69 (1752.6)	123 (3124.2)	102 (2590.8)	34 (863.6)	192 (4876.0)	32 (812.8)	34 (863.6)	66 (1676.4)
1500	2500	102 (2590.8)	90 (2286.0)	60 (1524.0)	75 (1905.0)	129 (3276.6)	102 (2590.8)	36 (914.4)	194 (4927.6)	38 (965.2)	34 (863.6)	66 (1676.4)
2000	3500	112 (2844.8)	90 (2286.0)	64 (1625.6)	81 (2057.4)	③	124 (3149.6)	38 (965.2)	218 (5537.2)	38 (965.2)	③	66 (1676.4)
2500	4500	120 (3048.0)	90 (2286.0)	66 (1676.4)	90 (2286.0)	③	130 (3302.0)	42 (1066.8)	226 (5740.4)	48 (1219.2)	③	66 (1676.4)

① Protector selected at 480V per Table 18.0-10 recommendations.

② Dimensions for overall width include a bussed transition—20.00 inches (508.0 mm) on the primary. This 20.00-inch (508.0 mm) section may be eliminated by using cable connections to primary bushing in lieu of buswork.

③ Consult Eaton for network disconnect information. If disconnect is remote from this location, then the transition box at top of protector is 30.00–36.00 inches (762.0–914.4 mm) above protector flange.

Table 18.0-17. Dry-Type Network—Weights in Lbs (kg)

Network Equipment		Weights in Lbs (kg)				
TX kVA	NP Amps	Primary SW + Fuses		Network TX ④	Protector NP + Stand ⑤	Network ND Disconnect
500	1200	2000 (908)		5600 (2542)	950 (431)	250 (114)
750	1600	2000 (908)		6700 (3042)	950 (431)	300 (136)
1000	1875	2000 (908)		8450 (3836)	950 (431)	350 (159)
1500	2500	2000 (908)		10,150 (4608)	1330 (604)	400 (182)
2000	3500	2000 (908)		13,150 (5970)	1550 (704)	⑥
2500	4500	2000 (908)		16,000 (7264)	1600 (726)	⑥

④ Dimensions and weights are for standard VPI or VPE Dry-Type designs, 80°C rise with fans with 150% continuous overload capacity and aluminum windings. Copper windings add more weight. Primary voltage is 15 kV, 95 kV BIL insulation.

⑤ Protector stand carries the weight of the protector, since the dry-type end sheets do not have the strength to support the weight of the protector.

⑥ Consult Eaton for network disconnect information. If disconnect is remote from this location then the transition box at top of protector is 30.00–36.00 inches (762.0–914.4 mm) above protector flange.

Dry-Type Network Unit—Switchgear Mounted Protector Dimensions

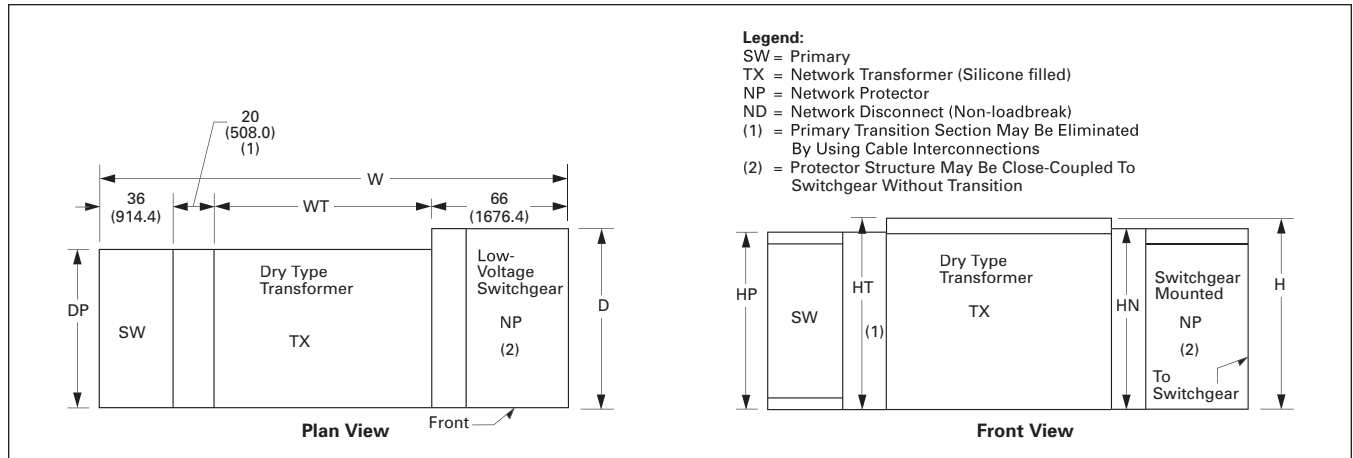

Figure 18.0-34. Dry-Type Network Unit Dimensions and Weights, Indoor Design with Switchgear Mounted Protector

Note: Dimensions and weights are for standard VPI or VPE Dry-Type designs, 80°C rise with fans with 150% continuous overload capacity and aluminum windings. Copper windings add more weight. Primary voltage is 15 kV, 95 kV BIL insulation.

Table 18.0-18. Dry-Type with Switchgear Mounted Protector—Dimensions in Inches (mm)

Network Equipment		Dimensions—Refer to Plan and Front View Figures Above							
TX kVA	NP Amps	HT	HP	HN	H	WT	W ^②	DP	D ^③
500	1200	90 (2286.0)	90 (2286.0)	96 (2438.4)	90 (2286.0)	102 (2590.8)	228 (5791.2)	66 (1676.4)	78 (1981.2)
750	1600	90 (2286.0)	90 (2286.0)	96 (2438.4)	90 (2286.0)	102 (2590.8)	228 (5791.2)	66 (1676.4)	78 (1981.2)
1000	1875	102 (2590.8)	90 (2286.0)	96 (2438.4)	102 (2590.8)	102 (2590.8)	228 (5791.2)	66 (1676.4)	78 (1981.2)
1500	2500	102 (2590.8)	90 (2286.0)	96 (2438.4)	102 (2590.8)	112 (2844.8)	238 (6045.2)	66 (1676.4)	78 (1981.2)
2000	3500	112 (2844.8)	90 (2286.0)	96 (2438.4)	112 (2844.8)	112 (2844.8)	238 (6045.2)	66 (1676.4)	78 (1981.2)
2500	4500	112 (2844.8)	90 (2286.0)	96 (2438.4)	112 (2844.8)	112 (2844.8)	238 (6045.2)	66 (1676.4)	84 (2133.6)

① Protector selected at 480V per **Table 18.0-10** recommendations.

② Primary transition section 20.00 inches (508.0 mm) in width may be eliminated by using cable interconnections. Elimination of transition reduces width by 20.00 inches (508.0 mm).

③ Dimensions are approximate for low voltage switchgear construction. Close-coupling to switchgear structures with main and feeders will require 72.00–78.00 inch (1828.8–1981.2 mm) depth depending upon the type of feeders used, fused or nonfused. When switchgear is remote, using cable or busway connections, the depth of the protector section can be reduced to 72.00 inches (1828.8 mm).

Table 18.0-19. Dry-Type with Switchgear Mounted Protector—Weights in Lbs (kg)

Network Equipment		Weight in Lbs (kg)		
TX kVA	NP Amps	Primary SW Including Power Fuses	Network Transformer TX ^④	Low Voltage Switchgear and Protector NP
500	1200	2000 (908)	5600 (2542)	4000 (1816)
750	1600	2000 (908)	6700 (3042)	4000 (1816)
1000	1875	2000 (908)	8450 (3836)	4000 (1816)
1500	2500	2000 (908)	10,150 (4608)	4400 (1998)
2000	3500	2000 (908)	13,150 (5970)	4600 (2088)
2500	4500	2000 (908)	15,600 (7082)	4600 (2088)

④ Dimensions and weights are for standard VPI or VPE Dry-Type designs, 80°C rise with fans with 150% continuous overload capacity and aluminum windings. Copper windings add more weight. Primary voltage is 15 kV, 95 kV BIL insulation.

This page intentionally left blank.